



RHIIP LISTSERV ARCHIVE

U.S Department of Housing and Urban Development

Office of Multifamily Housing Programs

The Multifamily Housing RHIP Listserv was established to provide the latest RHIP related news, occupancy tips and other items of information for the stakeholders of the various HUD subsidized multifamily programs. If you are interested in subscribing to the Listserv, please visit: www.hud.gov/subscribe/maillinglist.cfm. The weekly postings will be archived on the Multifamily RHIP webpage after every 10 postings.

Disclaimer: The content contained in the HUD Listserv does not create, modify or delete HUD Departmental policy; it is only intended to serve as an informational resource.

If you should have any occupancy related question, please contact your assigned contract administrator, or your RHIP Help Desk Representative. To find a list of the RHIP Help Desk Representatives, please visit: <http://www.hud.gov/offices/hsg/mfh/rhiip/helpdesk.pdf>.

#333 – 2015 PAC Renewal Instructions Announced

2015 PAC Renewal Instructions Announced

HUD has just released the instructions for renewing Project Assistance Contracts (PACs) for Fiscal Year (FY) 2015. The instructions provide guidance to the field for processing PAC renewals for FY2015. The expiring PACs may be renewed for a period of one year only. Headquarters sent the instructions to the field offices on March 24, 2015. The memorandum and the FY 2015 contract are available on the HUD website at http://portal.hud.gov/hudportal/HUD?src=/program_offices/housing/mfh

#332 – Updated: FY2015 Income Limits for Santa Clara, CA

Updated: FY2015 Income Limits for Santa Clara, CA

The income limits for Santa Clara, CA have been updated from their original levels. An anomaly was brought to HUD's attention and, after researching the anomaly, it was determined the original FY2015 Income Limits for Santa Clara were too low. The updated version on HUDUSER corrects this issue.

#331 – FY2015 Income Limits Released

FY2015 Income Limits Released

HUD has released its FY2015 Median Family Income estimates and FY2015 Income Limits. The FY2015 Income Limits were published on March 6, 2015, and are effective immediately. The income limits can be found at <http://www.huduser.org/portal/datasets/il.html>

#330 – OLHCHH Webinar on Successfully Adopting a Smoke-Free Housing Policy

OLHCHH Webinar on Successfully Adopting a Smoke-Free Housing Policy

On behalf of the U.S. Department of Housing and Urban Development's (HUD) Office of Lead Hazard Control and Healthy Homes (OLHCHH), you are [cordially invited](#) to attend an informative webinar:

How to Successfully Adopt a Smoke-Free Policy in Public and Multifamily Housing

Thursday, March 5, 2015
2:00 – 3:00 p.m. EST

[REGISTER TODAY!](#)

By joining this webinar, you will have an opportunity to:

- Gain insight from experienced Public Housing executives who have successfully implemented a smoke-free housing policy
- Advance your understanding of the steps involved in a typical implementation process for a smoke-free housing policy, and increase your awareness of effective strategies to get you started
- Enhance your knowledge about the true benefits of working with a community partner who has helped housing providers in establishing successful smoke-free policies

[Register today](#), space is limited!

#329 – 2015 Annual Adjustment Factors Announced

2015 Annual Adjustment Factors Announced

On February 9, 2015, a Notice of the Revised Contract Rent Annual Adjustment Factors (AAFs) for 2015 was published. The AAFs are used to adjust the contract rents on the anniversary date of the assistance contract for some multifamily projects. The AAFs are effective February 9, 2015.

A copy of the Federal Register containing the revised AAFs is located at:
<http://www.gpo.gov/fdsys/pkg/FR-2015-02-09/pdf/2015-02622.pdf>

The HUDUSER website has been updated to include the revised AAFs and can be viewed at <http://www.huduser.org/portal/datasets/aaf.html>

#328 – REMINDER: New Passbook Savings Rate Effective February 1, 2015

REMINDER: New Passbook Savings Rate Effective February 1, 2015

[Housing Notice 2014-15](#) *Passbook Savings Rate Effective February 1, 2015 and Establishing Future Passbook Savings Rates* has been posted to HUDCLIPS. As the title suggests, this notice establishes a new Passbook Savings Rate of 0.06% effective February 1, 2015 which supersedes the rate published in paragraph 5-7.F of HUD Handbook 4350.3, REV-1. The notice also provides explanation for how future Passbook Savings Rates will be adjusted.

To comply with the requirements of the notice, owners are required to use the new Passbook Savings Rate of 0.06% for all certifications effective February 1, 2015 and later. If owners have already completed a certification to be effective on February 1, 2015 or later, the certification will need to be corrected using the 0.06% rate. Additionally, HUD Handbook 4350.3, REV-1 and the HUD model lease permit tenants to request an interim recertification if their income changes before the next recertification. Because a reduction in the Passbook Savings Rate could reduce household income, tenants are permitted to request an interim recertification using the new 0.06% rate beginning February 1, 2015.

#327 – 30-Day Extension of TRACS 202.d Conversion Date

30-Day Extension of TRACS 202.d Conversion Date

A 30-day extension to the TRACS 202.d Conversion Date has been posted under the “What’s New” section of the [TRACS website](#). The release is titled [TRACS 202d Release Implementation Schedule](#).

The updated TRACS 202.d Release Implementation Schedule is as follows:

TRACS 202.d Release Conversion Start Date:	August 1, 2014
TRACS 202.c Release Conversion End Date:	February 27, 2015
TRACS 202.c Release Transactions will be Rejected:	March 2, 2015

#326 – Multifamily Housing EIV System 9.8 Release Summary

Multifamily Housing EIV System 9.8 Release Summary

The EIV system release 9.8 was successfully implemented on December 19, 2014, and has full functionality after the summarization was run on December 21, 2014. Below are the new functionalities that have been added to the Multifamily EIV system.

Any questions related to Multifamily Housing in EIV should be directed to the Multifamily Helpdesk at 1-800-767-7588 or by email at mf_eiv@hud.gov.

Function	Description
EIV – HQs Management Reports	
No HSC or HSU Role Assigned	<ul style="list-style-type: none">Report provided duplicative data in Certified Contracts/Projects Report and thus was <u>removed</u>.
EIV - Verification Reports	
New Hires Report	<ul style="list-style-type: none">Additional EIV report access has been granted to users with HFC user roles
Income Discrepancy Report	<ul style="list-style-type: none">Additional EIV report access has been granted to users with OIG, HFC, HSC and HSU user roles
Identity Verification Report	<ul style="list-style-type: none">Results for Percentage of household members who have failed on the statistics screen have been corrected to show results instead of a zero percent.

#325 – Housing Memorandum on Marijuana in Multifamily Assisted Properties

Housing Memorandum on Marijuana in Multifamily Assisted Properties

HUD's Office of Multifamily Housing has issued a memorandum titled [Use of Marijuana in Multifamily Assisted Properties](#). The memorandum, which is posted on the Multifamily Housing website, details how owners enforce the requirements found in the Controlled Substance Act and the Quality Housing and Work Responsibility Act of 1998.

#324 – Cost-of-Living Adjustment (COLA) for 2015

Cost-of-Living Adjustment (COLA) for 2015

See the below SSA release announcing that there will be a 1.7% COLA for 2015.

Cost-of-Living Adjustment (COLA) Information for 2015

Monthly Social Security and Supplemental Security Income (SSI) benefits for nearly 64 million Americans will increase 1.7 percent in 2015.

The 1.7 percent cost-of-living adjustment (COLA) will begin with benefits that more than 58 million Social Security beneficiaries receive in January 2015. Increased payments to more than 8 million SSI beneficiaries will begin on December 31, 2014.

#323 – Housing Notice on Waiting List Administration Published

Housing Notice on Waiting List Administration Published

[Housing Notice 2014-16](#) *Waiting List Administration* has been posted to HUDCLIPS. This notice provides additional options for owners in their waiting list administration to further ensure fair housing compliance and provides guidance on the administration of waiting lists for Multifamily Housing properties. Topics include opening the waiting list, placing applicants on the waiting list, and outreach.

#322 – New Passbook Savings Rate Published

New Passbook Savings Rate Published

[Housing Notice 2014-15](#) *Passbook Savings Rate Effective February 1, 2015 and Establishing Future Passbook Savings Rates* has been posted to HUDCLIPS. As the title suggests, this notice establishes a new Passbook Savings Rate of 0.06% effective February 1, 2015 which supersedes the rate published in paragraph 5-7.F of HUD Handbook 4350.3, REV-1. The notice also provides explanation for how future Passbook Savings Rates will be adjusted.

To comply with the requirements of the notice, owners are required to use the new Passbook Savings Rate of 0.06% for all certifications effective February 1, 2015 and later. If owners have already completed a certification to be effective on February 1, 2015 or later, the certification will need to be corrected using the 0.06% rate. Additionally, HUD Handbook 4350.3, REV-1 and the HUD model lease permit tenants to request an interim recertification if their income changes before the next recertification. Because a reduction in the Passbook Savings Rate could reduce household income, tenants are permitted to request an interim recertification using the new 0.06% rate beginning February 1, 2015.

#321 – FY2015 Fair Market Rents

FY2015 Fair Market Rents

The [FY2015 Fair Market Rents](#) (FMRs) became effective October 1, 2014 and were posted on [HUDUSER](#) the same day. These FMRs were announced in the [October 3, 2014 Federal Register](#).

#320 – Smoke-Free Action Guide Published

Smoke-Free Action Guide Published

The attached memorandum signed by Benjamin Metcalf, Deputy Assistant Secretary for Multifamily Housing Programs, provides specific steps for owners and management agents who choose to implement a smoke-free policy. Additionally, HUD's Office of Lead Hazard Control and Healthy Homes (OLHCHH) has published a Smoke-Free Action Guide entitled "Change is in the Air – An Action Guide for Establishing Smoke-Free Public Housing and Multifamily Properties". The purpose of the guide is to further educate PHAs and owners and management agents of subsidized or market rate multifamily housing about the benefits of smoke-free policies and recommended best practices to follow for implementing smoke-free policies. The guide is available for download from the Healthy Homes website at

http://portal.hud.gov/hudportal/HUD?src=/program_offices/healthy_homes or directly at <http://portal.hud.gov/hudportal/documents/huddoc?id=SMOKEFREEACTIONGUIDE.pdf>

Hard copies of the guide can be requested via email to Smokefreehousing@hud.gov.

Please direct any questions to Regina Aleksiewicz at regina.a.aleksiewicz@hud.gov.

#319 – Section 8 Contract Renewal Forms Posted to HUDCLIPS

Section 8 Contract Renewal Forms Posted to HUDCLIPS

The forms below, which relate to the Section 8 Contract Renewal process, have been updated and the new forms have been posted to HUDCLIPS. The updates include either a new OMB expiration date of 04/30/2017 or the removal of the OMB expiration date. Additionally, due to new software constraints, some forms that were previously fillable no longer have this functionality.

Form Number	Form Title
HUD – 90055	Use Agreement - Section 8 Use Agreement
HUD – 93181	PROJECT-BASED SECTION 8 HOUSING ASSISTANCE PAYMENTS Addendum to RENEWAL CONTRACT under Option One or Option Two for Capital Repairs and/or Acquisition Costs
HUD – 93182	PROJECT-BASED SECTION 8 HOUSING ASSISTANCE PAYMENTS Addendum to RENEWAL CONTRACT under Option One or Option Two for Capital Repairs and/or Acquisition--Post Rehabilitation Rents at Closing
HUD – 93184	RIDER TO ORIGINAL SECTION 8 HOUSING ASSISTANCE PAYMENTS CONTRACT
HUD – 9636	Project-based Section 8 HOUSING ASSISTANCE PAYMENTS BASIC RENEWAL CONTRACT - ONE-YEAR TERM
HUD – 9637	Project-based Section 8 HOUSING ASSISTANCE PAYMENTS BASIC RENEWAL CONTRACT - MULTI-YEAR TERM
HUD – 9638	Project-based Section 8 HOUSING ASSISTANCE PAYMENTS BASIC RENEWAL CONTRACT - FOR MARK-UP-TO-MARKET PROJECT
HUD – 9640	Project-based Section 8 HOUSING ASSISTANCE PAYMENTS INTERIM - (FULL) MARK-TO-MARKET RENEWAL CONTRACT
HUD – 9641	Project-based Section 8 HOUSING ASSISTANCE PAYMENTS INTERIM - (LITE) MARK-TO-MARKET RENEWAL CONTRACT
HUD – 9642	Project-based Section 8 HOUSING ASSISTANCE PAYMENTS FULL MARK-TO-MARKET RENEWAL CONTRACT
HUD – 9643	Project-based Section 8 HOUSING ASSISTANCE PAYMENTS WATCH LIST RENEWAL CONTRACT
HUD – 9644	PROJECT-BASED ASSISTANCE HOUSING ASSISTANCE PAYMENTS CONTRACT For Previous Mod Rehab Projects
HUD – 9648 A	Project-based Section 8 Contract Administration CONSENT TO ASSIGNMENT OF HAP CONTRACT AS SECURITY FOR FREDDIE MAC FINANCING
HUD – 9648 D	Project-based Section 8 Contract Administration CONSENT TO ASSIGNMENT OF HAP CONTRACT TO FNMA AS SECURITY FOR FNMA CREDIT ENHANCEMENT

HUD – 9649	Project-based Section 8 Contract Administration CONSENT TO ASSIGNMENT OF HAP CONTRACT AS SECURITY FOR FINANCING
HUD – 9651	Project-based Section 8 Contract Administration CONSENT TO ASSIGNMENT OF HAP CONTRACT AS SECURITY FOR FNMA FINANCING

#318 – 2015 Operating Cost Adjustment Factors (OCAFs) Published

2015 Operating Cost Adjustment Factors (OCAFs) Published

The Operating Cost Adjustment Factors (OCAF) for 2015 were published in the October 2, 2014 Federal Register. These factors are used for adjusting or establishing Section 8 rents under the Multifamily Assisted Housing Reform and Affordability Act of 1997 (MAHRA), as amended, for projects assisted with Section 8 Housing Assistance Payments. The factors are effective February 11, 2015 and can be found at <http://www.gpo.gov/fdsys/pkg/FR-2014-10-02/pdf/2014-23475.pdf>

Reminder for HUD and PBCA offices processing rent increases using Auto OCAF:
Once the 2015 Factors are updated in iREMS, please delete any Amend Rents record effective 02/11/2015 and beyond that was created either automatically or manually with the old 2014 Factor. A new record will automatically generate with the new 2015 Factor.

#317 – TRACS 202D MAT Guide Published

TRACS 202D MAT Guide Published

Multifamily Housing has posted the Monthly Activity Transmission (MAT) Guide for TRACS 202D. The guide, which provides information about the newest TRACS update and includes system guidance previously found in HUD Handbook 4350.3, REV-1, can be found at

http://portal.hud.gov/hudportal/HUD?src=/program_offices/housing/mfh/trx/trxdocs.

#316 – State Supplementary Payments (SSP) Administered by States

State Supplementary Payments (SSP) Administered by States

Multifamily Housing has recently been informed that some states no longer have their State Supplementary Payments (SSP), which supplement the Federal Supplemental Security Income (SSI) benefit, administered by the Social Security Administration (SSA). Because of this, SSA has advised they are not able to maintain any information about SSP in the states identified in their table below. The new protocol effects the income amounts provided by SSA to HUD and displayed in the Enterprise Income Verification (EIV) System. In order to verify the payment in states administering SSP, verification can be obtained by the tenant from the state office and as outlined in Chapter 5 and Appendix 3 of HUD Handbook 4350.3 REV-1. As explained in Chapter 5 of HUD Handbook 4350.3, REV-1, the verification must be provided within 120 days of the certification date and must not be older than 120 days from the date provided to the owner.

If the above causes a discrepancy in the EIV system, note the reason for the discrepancy and place in the tenant file.

The below information and tables can be found on SSA's website at <http://www.socialsecurity.gov/ssi/text-benefits-ussi.htm>.

STATE ADMINISTERED SUPPLEMENT

Alabama	Alaska	Arkansas	Colorado
Connecticut	Florida	Georgia	Idaho
Illinois	Indiana	Kansas	Kentucky
Louisiana	Maine	Maryland	Massachusetts
Michigan	Minnesota	Missouri	Mississippi**
Nebraska	New Hampshire	New Mexico	North Carolina
Ohio	Oklahoma	Oregon	South Carolina
South Dakota	Tennessee	Texas	Virginia
Washington	Wisconsin	Wyoming	Utah

SOCIAL SECURITY ADMINISTERED SUPPLEMENT

California	Delaware*	District of Columbia*	Hawaii
Iowa*	Montana	Nevada	New Jersey
New York*	Pennsylvania*	Rhode Island*	Vermont

* Dual administration State. In these States, Social Security administers some categories of State supplement payments, while the State administers other categories of supplemental payments.

NO STATE SUPPLEMENT

Arizona	Northern Mariana Islands
North Dakota	West Virginia
Mississippi**	

**Source data from the Social Security Administration website seems to conflict. Please check with your area Mississippi SSA office.

#315 – Multifamily Housing Section 8 Renewal Forms - Update

Multifamily Housing Section 8 Renewal Forms- Update

The Section 8 renewal forms were updated by OMB and posted to HUDCLIPS. HUD is currently working on upgrading fillable forms which will soon be posted for everyone's access. Until that time, please use the new forms that are currently posted. Thank you for your cooperation.

#314 – Multifamily Housing EIV System 9.7 Release Summary

Multifamily Housing EIV System 9.7 Release Summary

EIV system update 9.7 was successfully released on May 31, 2014, and will have full functionality once the summarization is run on June 7, 2014. Below are the new functionalities that have been added to Multifamily EIV.

Any questions related to Multifamily Housing in EIV should be directed to the Multifamily helpdesk at 1-800-767-7588 or by email at mf_eiv@hud.gov.

Function	Description
EIV	
Internet Explorer 10	<ul style="list-style-type: none">EIV has been upgraded with the Internet Explorer 10 (IE 10) browser. Only IE 10 and previous version will work with EIV. Other types of browsers are not supported by the EIV System.
Reports	<ul style="list-style-type: none">All reports that had mismatched project and contract names are corrected.
EIV – Income Information	
Income Report	<ul style="list-style-type: none">Income reports are now viewable for household members that have names greater than 19 characters.
Income Discrepancy Report	<ul style="list-style-type: none">The results from the Reported Annual Wages and Benefits from EIV have been adjusted to show cents instead of being rounded off to zero.Modification has been made to prevent future Dual Entitlement payments from doubling tenants income due to a SSA file reload.
EIV – HQs Management Reports	
HQs Management Reports	<ul style="list-style-type: none">When HUB, State or Servicing Center / Field Office is selected from the drop down menu in any of the HQs Management Reports, the radio button is automatically selected.
EIV - Verification Reports	
Identity Verification Report - Pending Verification Report	<ul style="list-style-type: none">Printer friendly report had page break reformatted to eliminate waste.
EIV - Audit Reports	
O/A Certification Report	<ul style="list-style-type: none">User is able to print full report now without erroring out.

#313 – Deadline Extended for Comments on the Revised Section 8 Renewal Policy Guide

Deadline Extended for Comments on the Revised Section 8 Renewal Policy Guide

On February 28, 2014 the Department posted the draft revised Section 8 Renewal Policy Guide for public comment. At that time the Department asked that all comments be submitted by April 30, 2014. The deadline for submitting comments has now been extended to May 14, 2014. The draft Guide can be found at http://portal.hud.gov/hudportal/HUD?src=/program_offices/housing/mfh/mfhsec8 under the section “What’s New”. Those interested in making comments can send them electronically to Section8RenewalGuide@hud.gov or via mail to the Department of Housing and Urban Development, Attention: Section 8 Renewal Guide, 451 7th Street, SW., Room 6134, Washington, DC 20410 – 0500. Comments must specifically identify the section number, page, and paragraph number to which they refer.

2014 PAC Renewal Instructions Announced

HUD has just released the instructions for renewing Project Assistance Contracts (PACs) for Fiscal Year (FY) 2014. The instructions provide guidance to the field for processing PAC renewals for FY2014. The expiring PACs may be renewed for a period of one year only. Headquarters sent the instructions to the field offices on February 19, 2014. The memorandum and the FY 2014 contract are available on the HUD website at http://portal.hud.gov/hudportal/HUD?src=/program_offices/housing/mfh/mfhsec8.

Revised Section 8 Renewal Policy Guide Posted for Public Comment

On February 28, 2014 the Department posted the draft revised Section 8 Renewal Policy Guide for public comment. The Section 8 Renewal Policy Guide is HUD's comprehensive guidance for renewing expiring Section 8 contracts. As part of these revisions and as described in the SUPPLEMENTAL INFORMATION section of this listserv, HUD is also advising the public that Section 9-23 of the Section 8 Renewal Policy Guide describes HUD's proposed revision to address when rents in a Rent Comparability Study (RCS) exceed 110 percent of the median gross rent by zip code.

The draft Guide can be found at http://portal.hud.gov/hudportal/HUD?src=/program_offices/housing/mfh/mfhsec8 under the section "What's New". Those interested in making comments should submit those comments by April 30, 2014 and can send them electronically to Section8RenewalGuide@hud.gov or via mail to the Department of Housing and Urban Development, Attention: Section 8 Renewal Guide, 451 7th Street, SW., Room 6134, Washington, DC 20410 –0500. Comments must specifically identify the section number, page, and paragraph number to which they refer.

SUPPLEMENTAL INFORMATION

With the enactment of the Multifamily Assisted Housing Reform and Affordability Act of 1997 (MAHRA)(42 U.S.C. 1437f note), Congress authorized the renewal of expiring contracts for project-based rental assistance issued under Section 8 of the United States Housing Act of 1937. MAHRA requires that, to the extent possible, renewal rents be comparable to unsubsidized rents in the area where the project is located. To this end, MAHRA further provides HUD with broad authority to prescribe the method for determining comparable market rent by comparison with rents charged for properties that are comparable as to neighborhood, type of location, access, street appeal, age, property size, apartment mix, physical configuration, property and unit amenities, utilities, and other relevant characteristics. Following the enactment of MAHRA, HUD published the Section 8 Renewal Policy Guide, Chapter Nine of which requires the preparation of a RCS as the method for determining comparability. Chapter Nine of the Section 8 Renewal Policy Guide also provides instructions on how a RCS is to be prepared and reviewed.

Research by the Department has shown that market rent estimates, as determined by an owner's RCS, are often higher than market rent estimates, as determined by a RCS secured by the Department. In May 2012, the Department issued new guidance to require appraisers to provide additional justification if the gross rent potential in the RCS exceeded 110 percent of the Fair Market Rent (FMR) in rural areas or the Small Area Fair Market Rent (SAFMR) in urban areas. The Department's

industry partners provided significant feedback regarding this new guidance, citing policy and technical concerns. In light of these considerations, the Department suspended implementation of the guidance in order to more thoroughly consider how best to address the Department's concerns regarding rent levels reflected in owner's RCSs.

After further consideration, including consultation with HUD's Office of Policy Development, and Research (PD&R), the Department proposes to implement a revised benchmark against which owner RCS rents can be assessed. As a preliminary matter, the Department believes the most reliable benchmark is a market-based, rather than a FMR-based, measure. Further, HUD believes that the most comprehensive market-based benchmark would be median gross rents, as determined and as published by the United States Census Bureau or some other comparable source. HUD considers these rents comprehensive because they are available for every zip code within the United States. The new guidance would require a comparison of the rents in the RCS to a market-based benchmark (i.e., median rent estimates published by the United States Census Bureau or other comparable source), should RCS rents exceed 110 percent of the median rents for the zip code area. Should this be the case, HUD will order a third party RCS and undertake a comparison of the RCSs.

#310 – Deceased Tenant Report Unavailable for Some Multifamily EIV Users

Deceased Tenant Report Unavailable for Some Multifamily EIV Users

The EIV IT team has advised us of an issue that is preventing approximately 2,455 MF EIV users with an HSC role or an HSU role from obtaining a complete Deceased Tenant Report. Specifically, properties that are assigned to an M-ID with only a contract number or only a project number will not appear in the Deceased Tenant Report. If a property is assigned to an M-ID with both a contract number and a project number, the property continues to appear in the Deceased Tenant Report.

If you are affected, document your files showing the inability to run the report and include a copy of this RHIP message. Contract Administrators are instructed not to issue MOR Findings if this issue is documented by a user until such time when the Deceased Tenant Report is fully functional. The fix to this issue is scheduled for February 14, 2014.

#309 – FY2014 Income Limits Released

FY2014 Income Limits Released

HUD has released its FY2014 Median Family Income estimates and FY2014 Income Limits. The FY2014 Income Limits were published on December 18, 2013, and are effective immediately. The income limits can be found at <http://www.huduser.org/portal/datasets/il/il14/index.html>.

#308 – Revised Transmittal for HUD Handbook 4350.3, REV-1, Change 4 Posted to HUDCLIPS

**Revised Transmittal for
HUD Handbook 4350.3, REV-1, Change 4
Posted to HUDCLIPS**

A revised transmittal for HUD Handbook 4350.3, REV-1, Change 4 has been posted to HUDCLIPS. In response to Multifamily Housing's business partner requests for a handbook implementation period, the Department is delaying the implementation of the requirements found in Change 4 until December 15, 2013. Owners/management agents will also have until March 1, 2014, to implement any change that requires modifications to TRACS software.

In addition to the revised implementation period, the revised transmittal identifies the removal of all appendices associated with Chapter 9 of HUD Handbook 4350.3 REV-1, Change 3. Specifically the following appendices found in Change 3 have been removed: Appendix 7-A, Appendix 7-B, Appendix 8, Appendix 9, Appendix 10 A, Appendix 10 B, Appendix 10 C, Appendix 10 D, Appendix 11, Appendix 12, and Appendix 13 (the old Appendix 14 is now Appendix 7). Further, small clarifications to verification techniques were made in paragraphs 5-13.B.2 and 9-10.A, Appendix 3 has been updated to match the verification requirements found in the rest of the handbook, and typographical errors identified by the industry have been corrected.

The file that contains the entire handbook is currently being completed. A link to this document will be posted when complete.

#307 – Multifamily Housing EIV System 9.6 Release Summary

Multifamily Housing EIV System 9.6 Release Summary

EIV system update 9.6 was successfully released on December 8, 2013, and will have full functionality once the summarization is run on December 15, 2013. Below are the new functionalities that have been added to Multifamily EIV.

Any questions related to Multifamily Housing in EIV should be directed to the Multifamily Helpdesk at 1-800-767-7588 or by email at mf_eiv@hud.gov.

Function	Description
EIV — Search Option	
Property ID	<ul style="list-style-type: none">EIV has added the ability to obtain data by utilizing Property ID search option along with Contract or Project numbers for rolls HQA, HDK, HFU, HFC, CAC and CAU in select reports.
EIV — HQs Management Reports	
Verification Report - Multiple Subsidy Summary Report	<ul style="list-style-type: none">Link for HFU Users added to get the list of properties receiving Multiple Subsidies in alphabetic order.
NO HSC or HSU Role Assigned Report	<ul style="list-style-type: none">No HSC or HSU Role Assigned Report added under HQ Management Reports menu with HQ, State and Field office search criteria. Has printable PDF reports and downloadable to Excel capability.
EIV — Verification Reports	
Existing Tenant Report	<ul style="list-style-type: none">Existing Tenant Report was modified to populate the Owner/Management Agent column with the Management Agent information as opposed to TRACS data, with a printer friendly version option.
Multiple Subsidy Report	<ul style="list-style-type: none">Two additional columns, Total Number of Properties with Tenants receiving Multiple Subsidy in MF, and MF and PIH were added to Multiple Subsidy Summary Report with printable PDF reports and downloadable to Excel.Search capability by Property ID added to Multiple Subsidy Report. Has printable PDF reports and downloadable to Excel capability.Multiple Subsidy Report is modified to populate the Owner/Management Agent column with the Management Agent information as opposed to TRACS data.
Identity Verification Report	<ul style="list-style-type: none">Additional search capability added by Property ID for Identity Verification Report's with a printer-friendly version.
Deceased Tenant Report	<ul style="list-style-type: none">Provides the search capability for Deceased Tenants Report by Property ID with a printer friendly version.

Cost-of-Living Adjustment (COLA) for 2014

See below SSA press release announcing that there will be a 1.5% COLA for 2014.

Social Security Announces 1.5 Percent Benefit Increase for 2014

Monthly Social Security and Supplemental Security Income (SSI) benefits for nearly 63 million Americans will increase 1.5 percent in 2014, the Social Security Administration announced today.

The 1.5 percent cost-of-living adjustment (COLA) will begin with benefits that more than 57 million Social Security beneficiaries receive in January 2014. Increased payments to more than 8 million SSI beneficiaries will begin on December 31, 2013.

Some other changes that take effect in January of each year are based on the increase in average wages. Based on that increase, the maximum amount of earnings subject to the Social Security tax (taxable maximum) will increase to \$117,000 from \$113,700. Of the estimated 165 million workers who will pay Social Security taxes in 2014, about 10 million will pay higher taxes as a result of the increase in the taxable maximum.

Information about Medicare changes for 2014 is available at www.Medicare.gov. The Social Security Act provides for how the COLA is calculated. To read more, please visit www.socialsecurity.gov/cola.

#305 – Reminder: Affordable Care Act Enrollment Starts October 1, 2013

Reminder: Affordable Care Act Enrollment Starts October 1, 2013
Find out more at www.HealthCare.gov

On October 1, 2013, the Health Insurance Marketplace opens in every state. With a single application, HUD-assisted tenants can see if their families qualify for Medicaid, for the Children's Health Insurance Program, or for subsidized health insurance premiums, and can enroll in coverage that begins as soon as January 1, 2014.

The benefits of the Affordable Care Act to HUD-assisted households is explained in this video message and blog post by Secretary Donovan, who explains how sharing information about the Affordable Care Act with HUD-assisted tenants contributes to HUD's mission of building strong and healthy communities across the country. [Click here for the video blog.](#)

The best place for the latest, most accurate, information on the Marketplace is the updated website, www.HealthCare.gov. At the site, you can learn what it is, who can apply for insurance, how to get insurance, how to lower costs, and more. Tenants can also call a toll free number, (800) 318-2596, to speak with a trained customer service representative. The site can also help connect you to people in local communities who can provide HUD-assisted tenants with personal help making insurance choices.

Please feel free to forward this to Multifamily owners and residents, your members and staff, and any other interested parties.

Ben Metcalf
Deputy Assistant Secretary
Office of Multifamily Housing Programs

#304 – 2014 Operating Cost Adjustment Factors (OCAFs) Published

2014 Operating Cost Adjustment Factors (OCAFs) Published

The Operating Cost Adjustment Factors (OCAF) for 2014 were published in the September 16, 2013 Federal Register. These factors are used for adjusting or establishing Section 8 rents under the Multifamily Assisted Housing Reform and Affordability Act of 1997 (MAHRA), as amended, for projects assisted with Section 8 Housing Assistance Payments. The factors are effective February 11, 2014 and can be found at <http://www.gpo.gov/fdsys/pkg/FR-2013-09-16/pdf/2013-22458.pdf>

Reminder for HUD and PBCA offices processing rent increases using Auto OCAF: Once the 2014 Factors are updated in iREMS, please delete any Amend Rents record effective 02/11/2014 and beyond that was created either automatically or manually with the old 2013 Factor. A new record will automatically generate with the new 2014 Factor.

#303 – Change 4 to HUD Handbook 4350.3 REV-1 Posted to HUDCLIPS

Change 4 to HUD Handbook 4350.3 REV-1 Posted to HUDCLIPS

Change 4 to HUD Handbook 4350.3 REV-1 "Occupancy Requirements of Subsidized Multifamily Housing Programs" has been posted to HUDCLIPS. The handbook is updated to include information on use of the Enterprise Income Verification (EIV) system; Violence Against Women Act (VAWA) requirements; Supplemental Information to Application for Federally Assisted Housing; Rent Refinement of Income and Rent Determination Requirements in Public and Assisted Housing Programs; Final Rule, and requirements relating to admission of individuals subject to State lifetime sex offender registration requirements. A complete listing of the updates can be found in the transmittal document attached to this message.

#302 – Implementation and Approval of Owner-Adopted Admissions Preferences for Individuals or Families Experiencing Homelessness – Housing Notice 2013-21 Posted to HUDCLIPS

Implementation and approval of owner-adopted admissions preferences for individuals or families experiencing homelessness – Housing Notice 2013-21 Posted to HUDCLIPS

Housing Notice 2013-21, Implementation and approval of owner-adopted admissions preferences for individuals or families experiencing homelessness, was issued July 25, 2013. This Notice provides guidance to HUD field offices, contract administrators, and property owners on the circumstances under which owners of assisted properties may adopt admissions preferences. This Notice clarifies 24 CFR §5.655(c)(1) - (c)(5) to allow for owners to adopt, with HUD approval, admissions preferences not specified in the regulation, in particular, a preference to house homeless families.

Should you have any questions about the Notice and/or the implementation of a homeless preference, please submit an email to the following email address: MFH_Homeless@hud.gov

**FY2013 Department of Homeland Security
Systematic Alien Verification for Entitlements (SAVE)
Code 33**

The Department of Homeland Security's SAVE system stands for Systematic Alien Verification for Entitlements. All Multifamily property managers use this system to check the legal background of individuals applying for housing assistance. HUD has just been advised that in June 2012, DHS, through the United States Congress, adopted a new category code for immigrants. This is **Code 33**, "Deferred Action for Childhood Arrivals". Deferred action is a discretionary determination to defer removal action of an individual as an act of prosecutorial discretion. Deferred action does not provide an individual with lawful status. This 2 year program is for people entering the country that have no criminal record, are in school (or graduated from), and under the age of 31.

The U.S. government is deferring action against these individuals (deportation) because they are low priority removals for the Department of Homeland Security. The deferred action can be removed at any time. These individuals do not have the required section 214 status as required by federal law. Persons with DACA status are **not eligible to receive HUD rental assistance** under the section 214 statute.

For further information please visit the SAVE Website below, or check the Code 33 Frequently Asked Questions.

You may also contact the DHS National Customer Service Center at 1-800-375-5283 or 1-800-767-1833 (TDD for the hearing impaired). Customer service officers are available Monday – Friday from 8 a.m. – 8 p.m. in each U.S. time zone.

Please visit the **SAVE website**: www.uscis.gov/SAVE

#300 – Multifamily Housing EIV System 9.5 Release Summary

Multifamily Housing EIV System 9.5 Release Summary

EIV system update 9.5 was successfully released on Monday May 6, 2013. The Multifamily weekend summarization job was successful on May 5, 2013, and all reports are current as of this date. Below are the new functionalities that have been added to Multifamily EIV.

Any questions related to Multifamily Housing in EIV should be directed to the Multifamily helpdesk at 1-800-767-7588 or by email at mf_eiv@hud.gov.

Function	Description
EIV — Income Reports	
New Hires Report	<ul style="list-style-type: none">• Display the Tenant's New Hires Data information for the past 6 months for each tenant• Displays the Tenant's New Hires Data only when a user clicks on tenant's SSN• Break is provided after each Member New Hire Data
Income Report	<ul style="list-style-type: none">• Displays Income Information for Verified Household Members when a Head of Household has failed the verification report due to personal identifier(s) not matching.• Displays Income Information for Verified Household Members when a Head of Household is an ineligible Non-Citizen that has Failed Pre-screening
EIV — Verification Reports	
Deceased Tenants Report	<ul style="list-style-type: none">• Eliminated duplicate records in the HQ Management Deceased Tenant Report
Income Discrepancy Report	For HQA, HQU, HFU, CAC, and CAU roles: <ul style="list-style-type: none">• Recognizes the discrepancies at different field office levels• Identifies tenants who have possibly underreported income through the use of incremental percentage options.• Report downloadable an Excel spreadsheet

#299 – FY2013 Updated Fair Market Rents Published

FY2013 Updated Fair Market Rents Published in Federal Register April 30, 2013

The FY2013 Fair Market Rents (FMRs) published by the Department on October 5, 2012, were updated April 30, 2013 with revised FMRs for Cheyenne, Wyoming, Odessa, Texas; Burlington-South Burlington, Vermont and a three-county group in northwest North Dakota (Mountrail County, Ward County and Williams County.)

2013 Fair market rent area	FMR by number of bedrooms in unit				
	0 BR	1 BR	2 BR	3 BR	4 BR
Burlington-South Burlington, VT MSA	902	980	1280	1604	1881
Cheyenne, WY MSA	508	578	781	1071	1251
Odessa, TX MSA	659	764	983	1251	1313
Mountrail County, ND	841	878	1041	1306	1817
Ward County, ND	773	825	1087	1602	1667
Williams County, ND	771	841	1026	1278	1371

These updated figures should be used by any program that uses FMRs. The updated figures can be found at: <http://www.gpo.gov/fdsys/pkg/FR-2013-04-30/pdf/2013-10171.pdf>

The October 5, 2012 Federal Register announcement can be found at <http://www.gpo.gov/fdsys/pkg/FR-2012-10-05/pdf/2012-24618.pdf>

#298 - Revised EIV Notice H 2013-06 Issued

Revised EIV Notice H 2013-06 Issued

Housing Notice 2013-06, Enterprise Income Verification (EIV) System, was issued today, March 12, 2013. This Notice supersedes Notices H 2011-21, H 2008-03, H 2009-20, and H 2010-10. The Notice is posted on HUDCLIPS at <http://portal.hud.gov/huddoc/13-06hsgn.pdf>.

The revised Notice:

- Adds Section 811 Project Rental Assistance Demonstration units under a Rental Assistance Contract to the Applicability section (Section II).
- Includes a description of the active link found in the Identity Verification Report Statistics. The resulting report identifies the number of households represented as not-verified (verification in process) (Section VII).
- Modifies the name of the No Income Report to No Income Reported by HHS or SSA (Section VII).
- Includes a description of the new report No Income Reported on 50059 and discusses how the report should be used (Section VII).
- Identifies the New Hires report as a Verification Report along with its previous location in the Income Reports section of the system (Section VII).
- Allows a violation for an owner/agent not having access and/or not using the EIV system in its entirety to be identified and the penalty to be assessed outside the scope of the MOR (Section XI).

#297 - Smoke-Free Housing Toolkits Posted to OHHLHC Website

Smoke-Free Housing Toolkits Posted to the Office of Healthy Homes and Lead Hazard Control's (OHHLHC) Website

The Department has posted smoke-free housing toolkits to OHHLHC's website at <http://portal.hud.gov/hudportal/HUD?src=/smokefreetoolkits1> and a cover letter introducing these toolkits has been attached to this message. These toolkits were developed by the Department of Housing and Urban Development and its partners, the Centers for Disease Control and Prevention, the American Lung Association, and the American Academy of Pediatrics and are designed to provide information on smoke-free housing policies and suggested steps to take when implementing a smoke-free housing plan.

**Social Security Benefits Move Fully Electronic
Effective by March 1, 2013**

Clarification on the Treatment of the Direct Express Debit Card

The U.S. Social Security Administration has a new policy which will eliminate the option for Social Security and SSI recipients to receive their benefits in the form of paper checks beginning on March 1, 2013. Recipients will continue to have the option to use direct deposit for their benefits or they may choose to receive a "Direct Express Debit Card." The debit card is automatically loaded with a recipient's benefits on the appropriate payment day of each month. The card is not associated with the recipient's bank account and funds cannot be added to the card by the card holder.

We have received several inquiries about the Direct Express Debit Card and how it will affect income and asset calculations for tenants of HUD subsidized properties. In order to remain consistent with HUD regulations, benefits received through direct deposit OR the Direct Express Debit Card will continue to be treated as income. The balance on the Direct Express Debit Card is also considered an asset and will be verified consistent with existing savings account verification requirements. Specifically, tenants who receive their benefit on a Direct Express Debit Card will need to provide an account balance no more than 120 days old at the time of recertification. This balance can be obtained from an ATM, through the online account service, or a paper statement. The verification document must identify the account and the account holder. If the total household assets do not exceed \$5,000, no income will be derived from this asset. If household assets exceed \$5,000, assets should be imputed at the standard rate of 2%.

For more information, please visit the SSA website at:
<http://www.ssa.gov/pubs/10073.html>

295 - Extension of Implementation Date for Form HUD-9834

Extension of Implementation Date for Form HUD-9834 *Management Reviews of Multifamily Projects*

As stated in RHIIP Listserv Posting #289, a revised form HUD-9834 *Management Reviews of Multifamily Projects* with an expiration date of 02/28/2015 has been posted to HUDCLIPS. Subsequent to this posting, HUD has received several requests to extend the implementation period for use of the new form when conducting Management and Occupancy Reviews for Multifamily Housing Projects. In response to these requests, the implementation period for the revised form HUD-9834 has been extended to March 4, 2013. This is to accommodate any needed software updates.

All Management and Occupancy Reviews started prior to March 4, 2013, can use the previous version of the form.

#294 - 2013 PAC Renewal Instructions Announced

2013 PAC Renewal Instructions Announced

HUD has just released the instructions for renewing Project Assistance Contracts (PACs) for Fiscal Year 2013. The instructions provide guidance to the field for processing PAC renewals for FY2013. Please note that the contract for FY2013 renewals contains changes (dates and authorizing legislative section). Please do not use the FY2012 contract. Headquarters sent the instructions to the field offices on January 16, 2013. The memorandum and the FY2013 contract are also available on the HUD website at

http://portal.hud.gov/hudportal/HUD?src=/program_offices/housing/mfh/mfhsec8

#293 - Timing of Income Eligibility Determinations - Clarification to Existing Policy

Timing of Income Eligibility Determinations Clarification to Existing Policy

Subsequent to the publication of RHIP Listserv #292 FY2013 Income Limit Implementation Policy, several individuals have requested clarification on the general policy relating to the timing of determining income eligibility. Specifically, is an applicant eligible to be housed from the waiting list if they have been determined to be eligible based on the prior year's income limits and, just prior to the applicant being housed, new income limits are published which would make the applicant ineligible? HUD Handbook 4350.3 REV-1, paragraph 3-6.C.2 states "Owners determine income eligibility prior to approving applicants for tenancy. Owners compare the family's annual income to the appropriate income limit prior to placing an applicant on the waiting list. However, owners may wait until a unit is available to verify the applicant's income eligibility." Following this guidance in the Handbook, if a unit becomes available and an applicant is selected from the waiting list, is processed for eligibility, and meets all eligibility requirements at the time of processing, the applicant is eligible to move-in to the project even if new income limits have been published.

Please be advised, this clarification of existing policy is in addition to the information provided in RHIP Listserv #292 which addressed the errors relating to the FY2013 Income Limits.

#292 - FY2013 Income Limit Implementation Policy

FY2013 Income Limit Implementation Policy

Please be advised the FY2013 income limits published by the Department on December 4, 2012, and identified in RHIP Listserv #290, were replaced with revised income limits on December 11, 2012. Because of the revision, the policy for implementing the FY2013 income limits is as follows:

- If an owner has not yet implemented the FY2013 income limits published either on 12/4/2012 or on 12/11/2012, the owner has 45 days from 12/11/12 to implement the 2013 income limits published on 12/11/2012.
- If an owner implemented the FY2013 income limits published on 12/4/2012, but not yet implemented the FY2013 income limits published on 12/11/2012, the owner must either:
 - a. Immediately implement the 2013 income limits published on 12/11/2012; or
 - b. Revert back to the 2012 income limits and implement the 2013 income limits published on 12/11/2012 within 45 days.
- If an owner has implemented the FY2013 income limits published on 12/11/2012, continue to use these income limits.

The data displayed on the website between 12/11/12 and 12/13/12 was accurate even though it may have indicated "Data file last updated Nov. 30, 2012." This notation has now been corrected to read "Data file last updated Tues., Dec. 11, 2012."

Important Note: Any applicant that was determined to be ineligible by using the FY2013 income limits published on 12/4/2012 must be contacted and, because they fall within the appeal timeframe of 14 days (HUD Handbook 4350.3 REV-1, paragraph 4-9.C.2.b), have their eligibility re-determined. The applicant's eligibility is to be re-determined using the FY2012 income limits.

#291 - Identity Verification Report Unavailable for 257 Multifamily EIV Users

Identity Verification Reports Unavailable for 257 Multifamily EIV Users

The EIV IT team has advised us that there is an issue preventing 257 MF EIV users from obtaining Identity Verification Reports. The issue affects only those users with MF EIV roles who do not have a single contract number assigned to their ID.

If you are affected, document your files showing the inability to run the report. Contract Administrators are instructed not to issue MOR Findings if this issue is documented by a user until such time when the Identity Verification Report is fully functional.

#290 - FY2013 Income Limits Released

FY2013 Income Limits Released

HUD has released its FY2013 Median Family Income estimates and FY2013 Income Limits. The FY2013 Income Limits are effective December 4, 2012 and can be found at <http://www.huduser.org/portal/datasets/il/il13/index.html>.

#289 - Form HUD-9834 Management Reviews of Multifamily Projects Posted To HUDCLIPS

Form HUD-9834 *Management Reviews of Multifamily Projects* Posted To HUDCLIPS

A revised form HUD-9834 *Management Reviews of Multifamily Projects* has been posted to HUDCLIPS. The form now has an expiration date of 02/28/2015 and is to be implemented for Management Reviews for Multifamily Housing Projects performed on or after December 4, 2012. All Management Reviews started prior to December 4, 2012, can use the previous version of the form. Updates to the form include organizational changes and additions for EIV and Lifetime Sex Offender Registration.

#288 - Form HUD-92006 Supplement to Application for Federally Assisted Housing Posted To HUDCLIPS

Form HUD-92006 Supplement to Application for Federally Assisted Housing Posted To HUDCLIPS

Form HUD-92006 *Supplement to Application for Federally Assisted Housing* has been approved by OMB and has been posted to HUDCLIPS. The form now has an expiration date of 11/30/2015. This form is referenced in Housing Notice 2012-09 *Supplemental Information to Application for Assistance Regarding Identification of Family Member, Friend, or Other Persons or Organization Supportive of a Tenant for Occupancy in HUD Assisted Housing* and must be used as described in this Notice.

#287 - Change to Online Security Training for EIV and TRACS

Change to Online Security Training for EIV and TRACS

Be advised the module for online security training for EIV and TRACS has changed. To complete the online security training, please follow the revised steps below.

- Open your internet browser
- Type <http://iase.disa.mil/eta/index.html#onlinetraining>
- Press Enter
- Click on **CyberAwareness Challenge (for DoD and Federal Personnel)** icon on the IA Education, Training and Awareness screen



CyberAwareness
Challenge
(for DoD and Federal
Personnel)
October 2012

- Click on Launch **CyberAwareness Challenge Federal Version** to proceed with the training

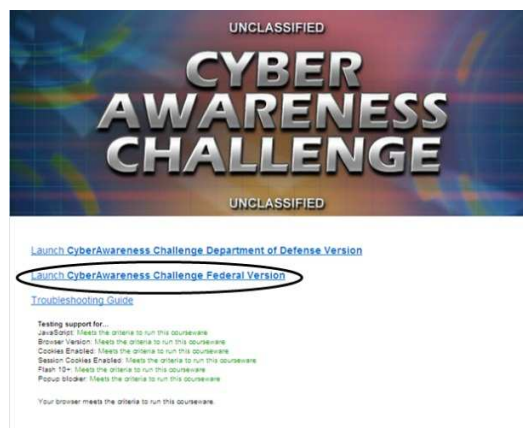

#286 - Further Encouragement for O/As to Adopt Optional Smoke-Free Housing Policies - Housing Notice 2012-22 Posted To HUDCLIPS

**Further Encouragement for O/As to Adopt Optional Smoke-Free Housing Policies
-- Housing Notice 2012-22 Posted To HUDCLIPS**

Housing Notice 2012-22, *Further Encouragement for O/As to Adopt Optional Smoke-Free Housing Policies*, has been signed and posted to HUDCLIPS and is located at <http://portal.hud.gov/huddoc/12-22hsgn.pdf>. This Notice re-issues Housing Notice 2010-21 and further encourages owners and management agents participating in one of Multifamily Housing rental assistance programs to adopt smoke-free housing policies if they have not yet done so.

#285 - System for Award Management (SAM) now LIVE!

System for Award Management (SAM) now LIVE!

Two key points for Users registering DUNS numbers in the SAM system:

- CCR no longer exists
- SAM (System for Award Management) has replaced CCR

SAM went live on July 29, 2012. If you had an account in CCR, all your information is now in SAM -- but your CCR login info will not work in SAM. Unless you opted out of the public search, you should be able to see your record by logging into SAM at <http://sam.gov> and doing a public search on your DUNS.

Unless a change in your business circumstances requires a change in order for you to be paid, or to be awarded a contract or a grant, you should not have to update your records right away (check your expiration date). If you need to update/renew/change your record, start by going to <http://sam.gov>, click on Create an Account, and follow the prompts to create an individual account and migrate your records/roles from CCR. The attached migration roles document will tell you how to do so. Then, log in, click on Register/Update Entity, find your record in the Complete Registrations section and begin your update. The attached updating or renewing document provides instructions. This document and other help options are available on the Help tab of sam.gov.

Should you encounter any issues in the process, please submit a ticket via the SAM help desk, which is called the Federal Service Desk (FSD) (<http://fsd.gov>). It is recommended you do so online, rather than wait on the phone on hold. If you don't have an account with FSD already, you'll need to create one on the "Your Account" page in order to submit a ticket.

Please note that SAM is completely free of charge, both to register and to use.

#284 - VA Aid & Attendance

VA Aid & Attendance

We have received several requests to clarify how VA Aid & Attendance payments are to be treated with respect to annual income and the regulation for medical expense exclusion (24 CFR 5.609(c)(4)). According to the U.S. Department of Veterans Affairs, Aid and Attendance (A&A) is an enhanced or special monthly pension benefit paid in addition to basic pension. An individual cannot be eligible for receiving A&A without first establishing eligibility for a basic VA pension. Below are the four instances the VA indicates a veteran may be eligible for A&A.

1. The Veteran requires the aid of another person in order to perform his or her activities of daily living, such as bathing, feeding, dressing, attending to the wants of nature, adjusting prosthetic devices, or protecting himself/herself from the hazards of his/her daily environment, **OR**,
2. The Veteran is bedridden, in that his/her disability or disabilities requires that he/she remain in bed apart from any prescribed course of convalescence or treatment, **OR**,
3. The Veteran is a patient in a nursing home due to mental or physical incapacity, **OR**,
4. The Veteran has corrected visual acuity of 5/200 or less, in both eyes, or concentric contraction of the visual field to 5 degrees or less.

There is no statutory or regulatory exclusion for the A&A benefit. Because of this, the benefit must be included as income.

Owners are reminded pursuant to 24 CFR 5.609(c)(4), any money received by the family that is specifically for, or in reimbursement of, the cost of medical expenses for any family member is excluded from annual income. Because of this, the owner must verify any amount provided for A&A which is used for medical expenses and exclude the verified amount. Any portion of the benefit not being used for medical expenses must be included as income.

#283 - Reminder for Contract Administrators and Owner Agents Processing Residual Receipts

Reminder for Contract Administrators and Owner Agents Processing Residual Receipts

HUD Notice H-2012-14 - Issued: August 3, 2012

We have received several incorrect miscellaneous payment requests for Residual Receipts offsets. To correctly submit these requests, please follow the instructions below.

VI. Owner Requirements

- A. In order to accomplish the Offset Process, project Owners must submit a miscellaneous payment request through the Contract Administrator along with their electronic monthly HAP voucher. The request must include: (a) the amount of the offset, expressed as a negative amount and (b) the text phrase "RR OFFSET" in the comment field, along with the actual offset amount inserted. **For example, if the project is using \$1,000.00 of Residual Receipts each month, the entry would be: "RR OFFSET -\$1,000.00"**

1. The miscellaneous payment request must be sent to "Field Office Initiated Accounting Adjustment," with a code of "FORQ." TRACS will automatically deduct the offset amount from the total voucher amount approved, thus assuring that the proper amount will be paid via TRACS.

#282 - 2013 Operating Cost Adjustment Factors (OCAFs) Published

2013 Operating Cost Adjustment Factors (OCAFs) Published

The Operating Cost Adjustment Factors (OCAF) for 2013 were published in the October 16, 2012 Federal Register. These factors are used for adjusting or establishing Section 8 rents under the Multifamily Assisted Housing Reform and Affordability Act of 1997 (MAHRA), as amended, for projects assisted with Section 8 Housing Assistance Payments. The factors are effective February 11, 2013 and can be found at <http://www.gpo.gov/fdsys/pkg/FR-2012-10-16/pdf/2012-25289.pdf>.

Reminder for HUD and PBCA offices processing rent increases using Auto OCAF: Once the 2013 Factors are updated in iREMS, please delete any Amend Rents record effective 02/11/2013 and beyond that was created either automatically or manually with the old 2012 Factor. A new record will automatically generate with the new 2013 Factor.

#281 - Cost-of-Living Adjustment (COLA) for 2013

Cost-of-Living Adjustment (COLA) for 2013

See below SSA press release announcing that there will be a 1.7% COLA for 2013.

#280 - “Partners in Housing” Advanced Preservation Training

“Partners in Housing” Advanced Preservation Training

Multifamily owners and senior level management company staff are invited to a free and informative HUD workshop on advanced approaches to preserving affordable multifamily properties.

This training builds upon the Basic “Partners in Housing” course. The Basic course is not a prerequisite, but participants must be familiar with HUD Multifamily programs, including Section 202 Direct Loans, Section 236, Section 8 rental assistance renewal options, and refinance programs such as Section 223(f) and Section 221(d)(4).

Industry experts will lead participants through case studies and discussions on options for refinancing and repositioning multifamily properties. We will also share the latest information on HUD programs. Training sessions will take place in five different cities. To register for one of the sessions and learn more about the program please use the following link:

<http://tdpsvs.com/hud/>

Sessions kick off in Denver on October 23-25, and run through January 2013 in Denver, Chicago, Los Angeles, Philadelphia and Boston.

Participants should come with calculators and be ready to work through detailed, applicable preservation case studies.

#279 - REVISION Clarification Concerning Effective Date of Recent Section 8 Page Changes

REVISION Clarification Concerning Effective Date of Recent Section 8 Page Changes

On May 18, 2012, the Department issued page changes to the Section 8 Renewal Policy Guide. Two of those changes have an impact on budget-based rent adjustment requests in Option Four. The first requires the use of current debt service in an Owner's budget-based rent increase request and the other permits a budget-based rent increase at the annual anniversary date only if the proposed rents do not exceed comparable market rents.

On June 12, 2012, the Department issued additional guidance related to the effective date of the page changes. Those effective dates have now been further clarified as noted below.

The effective date for both of the page changes described above is 150 days after May 18, 2012 (which is October 15, 2012). Any budget-based rent increase request postmarked prior to October 15, 2012 can be processed under the previous guidance. Any budget-based rent increase postmarked October 15, 2012 or thereafter must abide by the new guidance. This new requirement applies to all Option Four contracts, even multiyear contracts signed prior to May 18, 2012.

The effective dates for the other changes remain the same.

#278 - State Registered Lifetime Sex Offenders Housing Notice Updated

State Registered Lifetime Sex Offenders Housing Notice Updated

On June 12, 2012, the Office of Multifamily Housing and the Office of Public and Indian Housing published a joint notice titled "State Registered Lifetime Sex Offenders in Federally Assisted Housing." This joint notice updates and supersedes Housing Notice 2009-11.

The revised Notice strengthens language relating to the statutory- and regulatory-based responsibilities of owners and agents (O/As) to ensure that no lifetime registered sex offenders are admitted into federally assisted housing. The Notice provides, in part, the following:

- Applicants for admission into applicable HUD-assisted housing programs must provide a complete list of all states in which any household member has resided.
- PHAs and O/As must ask whether the applicant, or any member of the applicant's household, is subject to a lifetime sex offender registration requirement in any state.
- PHAs and O/As are reminded of their obligations with respect to Limited English Proficiency when processing applications of families for admission and also at the time of recertification.
- If an PHA or O/A discovers that a household member was erroneously admitted (the household member was subject to a lifetime registration requirement at admission and was admitted after June 25, 2001), the PHA or O/A must immediately pursue eviction or termination of assistance for the household member.

Please review Housing Notice 2012-11 in its entirety located on HUDCLIPS at http://portal.hud.gov/hudportal/HUD?src=/program_offices/administration/hudclips/notices/hsg

#277 - Clarification Concerning Effective Date of Recent Section 8 Page Changes

Clarification Concerning Effective Date of Recent Section 8 Page Changes

On May 18, 2012, the Department issued page changes to the Section 8 Renewal Policy Guide. Two of those changes have an impact on budget-based rent adjustment requests in Option Four. The first requires the use of current debt service in an Owner's budget-based rent increase request and the other permits a budget-based rent increase at the annual anniversary date only if the proposed rents do not exceed comparable market rents.

The effective date of these page changes is May 18, 2012. Any budget-based rent increase request postmarked prior to May 18, 2012 can be processed under the previous guidance. Any budget-based rent increase postmarked May 18, 2012 or thereafter must abide by the new guidance. This new requirement applies to all Option Four contracts, even multiyear contracts signed prior to May 18, 2012.

The effective dates for the other changes remain the same.

#276 - Multifamily Summarization Successful

Multifamily Summarization Successful

Please be advised the Multifamily Housing summarization job that ran on June 7, 2012, was successful. The EIV system is now available for use.

#275 - Multifamily Summarization Failed

Multifamily Summarization Failed

Please be advised the Multifamily Housing summarization job that ran on June 3, 2012, failed. Income Discrepancy reports will be available, however, all other reports will not. The cause of the failure has been identified and we are working to correct it. A message will be sent when the system is fully functional.

#274 - New Section 8 Renewal Guide Page Changes Posted

New Section 8 Renewal Guide Page Changes Posted

On May 18, 2012, the Department issued new page changes to the Section 8 Renewal Policy Guide. The transmittal sheet provides a summary of the changes. The changes are posted under "Page Changes May 18, 2012" at <http://www.hud.gov/offices/hsg/mfh/mfhsec8.cfm>. In addition, the pdf of the entire Guide has been updated on the same website and can be found under SECTION 8 RENEWAL POLICY GUIDE (updated 5-18-12).

The original transmittal memorandum indicated that Chapter 15 should be removed and replaced with a new Chapter 15. At this time there are no changes to Chapter 15 and the current pages dated 9/10/08 remain in force with respect to Chapter 15.

#273 - Form HUD-9834 Posted on HUDCLIPS

Form HUD-9834 Posted on HUDCLIPS

A revised form HUD-9834 was recently posted on HUDCLIPS. Subsequent to its posting, several errors were identified on both the Microsoft Word and the Adobe versions. Because of this, we have requested that the new form be removed from HUDCLIPS and the errors corrected. Please do not begin using the posted form with an expiration date of 02/28/2015. The previous version of the form will be reposted and will need to be used until corrections have been made to the new form. Further guidance on availability and implementation of this form will be provided in the future.

#272 - EIV SYSTEM 9.3 RELEASE

EIV SYSTEM 9.3 RELEASE

EIV system update 9.3 was successfully released on Saturday April 28, 2012. The Multifamily weekend summarization job was successful on April 29, 2012, and all reports are current as of this date. Below are the new functionalities that have been added to Multifamily EIV.

Any questions related to Multifamily Housing in EIV should be directed to the Multifamily helpdesk at 1-800-767-7588 or by email at mf_eiv@hud.gov.

EIV system changes for the 9.3 release include:

Function	Description
EIV System Access	
User Certification	<ul style="list-style-type: none">Removed the step to certify the user after approval of CAAF or UAAF. User Certification now happens when a CAAF or UAAF is approved.
Income Reports	
By Head of Household By Contract Number By Project Number	<ul style="list-style-type: none">Fixed the discrepancy in decimal amount between the income by head of household and the income by contract and project detail reports.
Verification Reports	
Deceased Tenant Report	<ul style="list-style-type: none">Individual month options have been removed leaving only the ability to choose "All" months.
Identity Verification Reports	<ul style="list-style-type: none">Individual month options have been removed leaving only the ability to choose "All" months.Number of households represented as Not-Verified (verification in process) is now a clickable link which identifies individuals who have not yet been verified by SSA. The report is arranged by head of household.
System Functionality	
Java Errors	<ul style="list-style-type: none">Fixed Java error when displaying Dual Entitlement payment history by head of household or by the SSN link from the summary page.Fixed the Java error when printing the Existing Tenant Search report.

#271 - 2012 Annual Adjustment Factors Announced

2012 Annual Adjustment Factors Announced

On April 13, 2012, a Notice of the Revised Contract Rent Annual Adjustment Factors (AAFs) for 2012 was published. The AAFs are used to adjust the contract rents on the anniversary date of the assistance contract for some multifamily projects. The AAFs are effective April 13, 2012. A copy of the Federal Register containing the revised AAFs is located at: <http://www.gpo.gov/fdsys/pkg/FR-2012-04-13/pdf/2012-8971.pdf>

REMINDER*REMINDER**

Notice Requiring Owners with Project-Based Rental Assistance Contracts or Section 202 or 811 Project Rental Assistance Contracts to Obtain Dun and Bradstreet Numbering System (DUNS) Numbers and to Register in the Central Contractor Registration (CCR)

Notice H 2011-01 was issued on January 5, 2011, providing the regulatory reporting requirements and guidance for legal entities receiving federal assistance. Rental assistance payments made under Project-Based Section 8 or Section 202 or 811 Project Rental Assistance Contracts are covered under these requirements. The Department will issue a Housing Notice shortly clarifying that this requirement also applies to RAP and Rent Supplement contracts. Owners were required by Notice H 2011-01 to have obtained a DUNS number and have an active, valid registration in the Central Contractor Registration (CCR) within 60 days of the publication date of the Notice and submit Attachment A , DUNS Number and CCR Registration Certification to their local HUD office to verify compliance. The Notice further clarified that an Owner's failure to obtain a DUNS number and CCR registration within the timeframe allotted may result in the suspension of housing assistance payments or rental assistance payments.

HUD HQs ran a listing of DUNS numbers received in response to the Notice against an extract received from CCR to ensure compliance. There are still Owners who have failed to obtain a DUNS Number and to Register in the CCR system. In order to continue to receive housing assistance payments or rental assistance payments, Owners are **reminded** that they must comply with the requirements of Notice H 2011-01.

Finally, CCR requires Owners to recertify annually, and Notice H 2011-01 requires Owners to maintain their CCR registration. Please note that the Department will be implementing a new Funding System in May 2012 (information provided soon). As a result, Owners who are not in compliance with the requirements of this Notice **by April 23, 2012**, risk suspension of their housing assistance or rental assistance payments.

Thank you for your cooperation in complying with these requirements. Your prompt attention to this matter is requested in order to prevent any disruption of payments under housing or rental assistance contracts.

Questions regarding the Notice should be directed to Theresa Fields, Housing Project Manager, Office of Housing Assistance Contract Administration Oversight for Multifamily Housing Programs. Ms. Fields' telephone number is (202) 402-2703.

#269 - Multifamily Summarization Failed 1/29/2012

Multifamily Summarization Failed 1/29/2012

Please be advised the Multifamily Housing summarization job that ran on January 29, 2012, failed. Income Discrepancy reports will not be available and all other reports will be as of January 22, 2012. The cause of the failure is being investigated.

#268 - 2012 PAC Renewal Instructions Announced

2012 PAC Renewal Instructions Announced

HUD has just released the instructions for renewing Project Assistance Contracts (PACs) for 2012. The instructions provide guidance to the field for processing PAC renewals for FY 2012. Please note that the contract for FY 2012 renewals contains changes (dates and authorizing legislative section). Please do not use the FY 2011 contract. Headquarters sent the instructions to the field on February 1, 2012.

The memorandum and the FY 2012 contract are also available on the HUD website at: http://portal.hud.gov/hudportal/HUD?src=/program_offices/housing/mfh/mfhsec8

#267 - EIV Existing Tenant Search Clarification

EIV Existing Tenant Search Clarification

Recently we have been asked to clarify what documentation is needed in an applicant's file if the applicant household is rejected for a reason identified in an owner's Tenant Selection Plan. The policies for rejecting applicants have not changed with the addition of the EIV Existing Tenant Search screening criteria.

HUD Handbook 4350.3 REV-1, paragraph 4-9 allows an owner to reject an applicant if the applicant is ineligible for occupancy in a particular unit or property. There are several program and project eligibility requirements that must be met by an applicant household. If an applicant fails to meet one of these eligibility requirements, the applicant is considered ineligible for occupancy and must not be housed from the waiting list. Accordingly, once the applicant is determined to be ineligible for occupancy there is no need to continue screening the applicant household for any other eligibility factor including the EIV Existing Tenant Search. The applicant file must contain documentation demonstrating ineligibility but does not necessarily need to contain the EIV Existing Tenant Search.

If an applicant household is being housed from the waiting list, the EIV Existing Tenant Search, along with all other program and project eligibility requirements, must be performed and the documentation must be retained in the tenant file.

#266 - 2012 Operating Cost Adjustment Factors (OCAFs) Updated in iREMS

2012 Operating Cost Adjustment Factors (OCAFs) Updated in iREMS

The Operating Cost Adjustment Factors (OCAF) for 2012 were updated in iREMS on November 03, 2011. These factors are used for adjusting or establishing Section 8 rents under the Multifamily Assisted Housing Reform and Affordability Act of 1997 (MAHRA), as amended, for projects assisted with Section 8 Housing Assistance Payments. The factors are effective February 11, 2012, and can be found at <http://www.gpo.gov/fdsys/pkg/FR-2011-10-26/pdf/2011-27816.pdf>.

Reminder for HUD and PBCA offices participating in the Auto OCAF Pilot:

Now that the 2012 Factors are updated in iREMS, please delete any Amend Rents record effective 02/11/2012 and beyond that was created either automatically or manually with the old 2011 Factor. A new record will automatically generate with the new 2012 Factor.

#265 - EIV SYSTEM 9.2.1 RELEASE

WHAT'S NEW IN THE EIV SYSTEM 9.2.1 RELEASE

Multifamily Housing Functionalities

EIV System 9.2.1 was successfully released last week. Below are the new functionalities that have been added to Multifamily EIV.

Any questions related to Multifamily Housing in EIV should be directed to the Multifamily helpdesk at 1-800-767-7588 or by email at mf_eiv@hud.gov.

WHAT'S NEW IN THE EIV SYSTEM 9.2.1 RELEASE FOR MF USERS?

The table below describes changes included in the EIV system 9.2.1 release.

Function	Description
HQ Management Reports	
Usage/Termination Summary	<ul style="list-style-type: none">EIV has been modified to include access to the EIV verification reports in the Usage Report.
Income Reports	
By Contract Number By Project Number	<ul style="list-style-type: none">Dual Entitlement (DE) will be displayed when users access income data By Contract Number and By Project Number options.DE will not be displayed when accessing income data through the By Head of Household option.
System Functionality	
All MF External Users	<ul style="list-style-type: none">Functionality has been enhanced to allow for users to hit the enter key to produce a report instead of having to click on the Go button for the By Contract Report and the By Project Report.

#264 - 2012 Operating Cost Adjustment Factors (OCAFs) Published

2012 Operating Cost Adjustment Factors (OCAFs) Published

The Operating Cost Adjustment Factors (OCAF) for 2012 were published in the October 26, 2011 Federal Register. These factors are used for adjusting or establishing Section 8 rents under the Multifamily Assisted Housing Reform and Affordability Act of 1997 (MAHRA), as amended, for projects assisted with Section 8 Housing Assistance Payments. The factors are effective February 11, 2012. The factors can be found at <http://www.gpo.gov/fdsys/pkg/FR-2011-10-26/pdf/2011-27816.pdf>.

Reminder for HUD and PBCA offices participating in the Auto OCAF Pilot:

Once the 2012 Factors are updated in iREMS, please delete any Amend Rents record effective 02/11/2012 and beyond that was created either automatically or manually with the old 2011 Factor. A new record will automatically generate with the new 2012 Factor.

#263 - Cost-of-Living Adjustment (COLA) for 2012

Cost-of-Living Adjustment (COLA) for 2012

See below SSA press release announcing that there will be a 3.6% COLA for 2012.

Wednesday, October 19, 2011
For Immediate Release

Press Office
410-965-8904

Social Security Announces 3.6 Percent Benefit Increase for 2012 Cost-of-Living Adjustment is First Since 2009

Monthly Social Security and Supplemental Security Income (SSI) benefits for more than 60 million Americans will increase 3.6 percent in 2012, the Social Security Administration announced today.

The 3.6 percent cost-of-living adjustment (COLA) will begin with benefits that nearly 55 million Social Security beneficiaries receive in January 2012. Increased payments to more than 8 million SSI beneficiaries will begin on December 30, 2011.

Some other changes that take effect in January of each year are based on the increase in average wages. Based on that increase, the maximum amount of earnings subject to the Social Security tax (taxable maximum) will increase to \$110,100 from \$106,800. Of the estimated 161 million workers who will pay Social Security taxes in 2012, about 10 million will pay higher taxes as a result of the increase in the taxable maximum.

Information about Medicare changes for 2012, when announced, will be available at www.Medicare.gov. For some beneficiaries, their Social Security increase may be partially or completely offset by increases in Medicare premiums.

The Social Security Act provides for how the COLA is calculated. To read more, please visit www.socialsecurity.gov/cola.

#262 - HUD Announces the New Tenant Resource Network Program (TRN) for Section 8 Preservation

HUD Announces the New Tenant Resource Network Program (TRN) for Section 8 Preservation

Dear Multifamily Owner:

In the next week, The Department plans to publish a Notice of Funding Availability (NOFA) for the Tenant Resource Network Program (TRN), a new program to facilitate the preservation of projects with Section 8 Project Based Rental Assistance at-risk of loss. TRN considers projects at-risk upon occurrence of one of the following events: an FHA insured or Direct mortgage maturity date within 24 months of the publication of the NOFA; an owner election to Opt-Out filed no more than 12 months prior to publication of the NOFA; a notice of prepayment filed no more than 12 months prior to publication of the NOFA; or the receipt of two consecutive Below 60 REAC scores (not yet under abatement), with the most recent score issued no more than 12 months prior to the publication of the NOFA.

TRN is designed to inform, educate and engage tenants regarding their rights, responsibilities and options in the event their housing is impacted by one of these events. The program is intended to be one more tool to assist both owners and the Department in identifying potential preservation strategies or, in the event preservation is not feasible, to ensure that tenants are fully informed regarding available protections such as the provision of tenant protection Housing Choice Vouchers. The program will enhance the Department's partnership with owners by providing an additional perspective on how preservation may be achieved, and will allow owners to make more fully informed decisions regarding continued participation in Multifamily programs.

The NOFA will announce the availability of approximately \$10 million made available under the authority of Section 514 of the Multifamily Assisted Housing Reform and Affordability Act of 1997 (MAHRA) for tenant outreach at projects defined by HUD as TRN-eligible. Eligible applicants are non-profits with a minimum of five years of tenant outreach and organizing activities. TRN is specifically targeting Metropolitan Statistical Areas (MSAs) with the largest numbers of TRN-eligible units, and may provide additional award funds to applicants working in these communities that are disproportionately impacted by the potential loss of assisted housing. Eligible projects qualified for TRN grantees to perform eligible activities will be published with the NOFA. Although projects will be selected by HUD as eligible under the program, they will not necessarily be selected by TRN grantees to perform eligible activities. HUD will monitor grantees over the award period to ensure they are in compliance with the program, following a HUD approved Workplan, administering funds properly and achieving performance goals.

The NOFA will be published on <http://www.grants.gov/> . A webcast training session will be held the week following publication and can be found on <http://portal.hud.gov/hudportal/HUD?src=/webcasts/schedule> .

Please contact Claire Trivedi at 202-708-3000 Claire.m.trivedi@hud.gov , Margaret Salazar at 202-402-2423 margaret.s.salazar@hud.gov or Stan Houle 202-402-2572 stanley.r.houle@hud.gov with questions.

#261 - Revised EIV & You Brochure Notice Issued

Revised EIV & You Brochure Notice Issued

Notice, H 2011-25, Enterprise Income Verification (EIV) & You Brochure – Requirements for Distribution and Use, was issued on September 20, 2011. This Notice revises Notice 2010-02, which was issued prior to EIV use becoming mandatory on January 31, 2010. The instructions to owners and management agents (O/As) remain the same on the distribution and use of the *EIV & You* brochure. The Notice is posted on HUDCLIPS at <http://www.hud.gov/offices/adm/hudclips/notices/hsg/>.

#260 - Resident's Rights & Responsibilities Brochure Available in Braille

Resident's Rights & Responsibilities Brochure Available in Braille

The Resident's Rights & Responsibilities Brochure (English version) is now available in Braille. Copies of the document in Braille are available from the Multifamily Housing Clearinghouse. The Clearinghouse can be reached by calling 1-800-685-8470. There is a limit of 20 documents per order. The document is not available online. The brochure (non-Braille) is also available in other languages (Amharic, Arabic, Armenian, Cambodian, Chinese, Farsi, French, Korean, Portuguese, Russian, Spanish, Tagalog, and Vietnamese). These translated versions of the brochure are available on HUD's Limited English Proficiency website at http://portal.hud.gov/hudportal/HUD?src=/program_offices/fair_housing_equal_opp/promotingfh/lep.

#259 - Revised EIV Notice 2011-21 Issued

Revised EIV Notice 2011-21 Issued

Housing Notice 2011-21, Enterprise Income Verification (EIV) System, was issued today, August 19, 2011. This Notice supersedes Notices H 2008-03, H 2009-20, and H 2010-10. The Notice is posted on HUDCLIPS at <http://portal.hud.gov/hudportal/documents/huddoc?id=11-21hsgn.pdf>.

The revised Notice:

- Clarifies that IPAs may use printed EIV documents when auditing an owner's compliance (An IPA is an Independent Public Auditor hired to audit a property's financial statements)
- Clarifies the requirement on resolving discrepancies between TRACS and the current form HUD-50059
- Indicates the following reports must be run by selecting the "All" recertification month:
 - No Income Report
 - New Hires Report
 - Identity Verification Report
 - Deceased Tenant Report
- States the O/A must make sure that the income appearing on the EIV Income Report does not meet a regulatory income exclusion.
- Clarifies that a tenant's monthly repayment agreement payment may exceed 40% of the family's monthly adjusted income if the family agrees to the amount stated in the repayment agreement.
- Recommends that an O/A has the head of household and, if applicable, the family member who had the unreported income sign a repayment agreement.
- Indicates the comment field on the voucher must be completed when explaining payment and costs retained even if no costs were retained.
- Identifies an updated penalty for not using the EIV system. The O/A will now incur a penalty of a five percent decrease in the voucher payment for the month following the date the violation was found and each subsequent voucher payment until the MOR finding is cured.
- Indicates a new security training requirement. EIV users are now required to complete the online Federal ISS Awareness training program. The most recent HUD EIV webcast will no longer satisfy the security training requirement.
- Clarifies that when mailing EIV data, data must be sent to an office of the O/A and must not be mailed to Independent Auditor offices
- New Attachment 9: Assessing the Five Percent Penalty in Voucher Payment has been added
- New Attachment 10: Sample Tenant Consent to Disclose EIV Income Information has been added

#258 - Notice on Bed Bugs Issued

Notice on Bed Bugs Issued

Housing Notice 2011-20, Guidelines on Bed Bug Control and Prevention in HUD Insured and Assisted Multifamily Housing, has been issued today, August 19, 2011. This Notice provides information and references to best practices regarding the prevention and control of bed bug infestations. It also provides guidance on the rights and responsibilities of HUD, Owners and Management Agents (O/As) and tenants with regard to bed bug infestations. The Notice has been attached and is also available on HUDCLIPS at <http://portal.hud.gov/hudportal/documents/huddoc?id=11-20hsgn.pdf>.

#257 - Attention Multifamily EIV Users

Attention Multifamily EIV Users

We have been made aware that some tenants are not appearing in EIV and we are researching this issue to discover the cause. In the meantime, we ask that you take the following steps. While completing a recertification, if you receive this message from the "By Head of Household" query, **"A current form 50059 record was not found for Social Security Number: XX-XXX-1234"**, please check the Identity Verification Report to determine if the tenant is listed. If the tenant is listed, make the required corrections noted on the report and transmit the corrected form 50059 to TRACS.

Print the "By Head of Household" report that reflects the message above and place it in the tenant file, ensuring that the date it was printed is on the page. Continue your recertification by the traditional third party method.

Thank you for your patience. We hope to have this issue resolved in the near future.

#256 - Are Social Security "Cents" Included as Income?

Are Social Security "Cents" Included as Income?

We have received requests for further clarification to RHIP Listserv messages #229 and #231 on how to calculate Social Security income and/or Medicare when the amounts in the EIV system differ from the amounts represented on the SSA Award Letter. Specifically, which document do you use when the Social Security Award Letter indicates a "cents" amount being received and the EIV Income Report does not.

Housing Notice 2010-10 states the Income Report identifying the Social Security benefit information in EIV must be used as third party verification of the tenant's income and will be used to calculate the tenant's income. Additionally, the O/A must confirm with the tenant that the current benefit amount in EIV is correct. If the tenant agrees that the Social Security benefit information reported in EIV is correct, the O/A must use the gross benefit amount reported in EIV for calculating the tenant's income by annualizing the gross benefit amount projected forward for the next 12 months. This requirement allows the O/A to use the amount represented in EIV (even if no cents are included) to calculate income. Social Security Award Letters are not required to be viewed or included in the tenant's file if the EIV Income Report is being used to verify and calculate benefits.

The SSA award letter should be used to calculate income and included in the tenant's file only if the tenant disputes the amount(s) on the EIV Income Report. Having the SSA Award Letter in the file is not in itself an indication that the tenant disputes the amount(s) on the EIV Income Report. The O/A should make a note on the EIV Income Report that the tenant disputes the amount and then use the Social Security Award Letter to calculate income. The award letter must not be older than 120 days. Please refer to Notice H 2010-10 for instructions when the tenant does not have his/her Social Security Award Letter or when the letter is older than 120 days.

#255 - Tax Credit Compliance Fees in Section 8 Projects

Tax Credit Compliance Fees in Section 8 Projects

Please see the attached memorandum from Willie Spearmon for all Multifamily Hub Directors, Multifamily Program Center Directors, Performance-Based Contract Administrators, and Multifamily Project Managers. The purpose of the memorandum is to provide further information regarding Tax Credit compliance fees in Section 8 projects.

#254 - WHAT'S NEW IN THE EIV SYSTEM 9.2 RELEASE

WHAT'S NEW IN THE EIV SYSTEM 9.2 RELEASE

Multifamily Housing Functionalities

EIV System 9.2 was successfully released last week. Below are the new functionalities that have been added to Multifamily EIV.

Any questions related to Multifamily Housing in EIV should be directed to the Multifamily helpdesk at 1-800-767-7588 or by email at mf_eiv@hud.gov.

WHAT'S NEW IN THE EIV SYSTEM 9.2 RELEASE FOR MF USERS?

The table below describes changes included in the EIV system 9.2 release.

Function	Description
EIV — Management Reports	
For Headquarters and Field Office Staff	EIV Usage Summary now includes 180-day statistics.
EIV — User Certification Process	
For Helpdesk, Tier 2 staff and Owners/Agents	Added Property Names to User Certification Report to assist users referencing properties for HSC and CAC roles.
EIV — ServiceDesk	
For Internal Users (HDQ)	Upgraded HDQ role to access other internal roles.
EIV — Income Information Reports	
Income Report	Contract Number and Project Number fields are no longer case sensitive. Contact/Project radio buttons now populate automatically once the Contract Number and Project Number are entered. Created a Certification Page to be used as an option by the owners/agents.

Function	Description
Income Discrepancy Report	<p>Last name with masked SSN will appear on report pop-up when there is no income discrepancy condition for the household.</p> <p>When printing the Report, the current date will be printed at the bottom of the page.</p>
EIV — Verification Reports	
All Verification Reports	<p>Provided a drop down list for contracts and projects for HUD Field Office and External users.</p> <p>Contract Number and Project Number fields are no longer case sensitive.</p> <p>Contact/Project radio buttons now populate automatically once the Contract Number and Project Number are entered.</p>
Deceased Tenants Report	<p>Developed recognition of TRACS Move Outs to eliminate those tenants from this report.</p> <p>Next recertification date has been removed from report.</p>
Multiple Subsidy Report	<p>Combined reporting of individuals receiving multiple subsidies from both the Search within MF only and the Search within MF and PIH reports.</p> <p>System now differentiates between Active tenants and Inactive tenants in TRACS to eliminate false reporting.</p> <p>Lists contracts and projects with households receiving multiple subsidies for selected HUD Offices (HFU role) for month or calendar year in alphabetic order.</p>

#253 - 2011 Annual Adjustment Factors Announced

2011 Annual Adjustment Factors Announced

On March 16, 2011, a Notice of the Revised Contract Rent Annual Adjustment Factors (AAFs) for 2011 was published. The AAFs are used to adjust the contract rents on the anniversary date of the assistance contract for some multifamily projects. The AAFs are effective March 16, 2011. A copy of the Federal Register containing the revised AAFs is located at: <http://www.huduser.org/portal/datasets/aaf.html>

#252 - Clarification HUDCLIPS Form HUD-9887 – 9887-A

**Clarification
HUDCLIPS Form HUD-9887 – 9887-A**

There have been several requests to provide additional detail about the OMB expiration date and where it is found along with questions regarding the 02/2007 effective date.

The revised Form HUD-9887 – 9887-A that has been posted to HUDCLIPS has a new OMB expiration date of 6/30/2012. The expiration date can be found on the second page of the document. The revised form still shows the 02/2007 revision date, which is accurate; this is the effective date of the form, indicating that its content has not been changed since that date.

As a reminder, no OMB expiration date or OMB approval number is required on Form HUD-9887 – 9887-A.

#251 - HUDCLIPS Form HUD-9887 - 9887-A

HUDCLIPS Form HUD-9887 – 9887-A

A revised Form HUD-9887 – 9887-A has been posted to HUDCLIPS. The revision updates the OMB expiration date to 6/30/2012. As a reminder, no OMB expiration date or OMB approval number is required on Form HUD-9887 – 9887-A.

#250 - Options for Annual EIV Security Training

Options for Annual EIV Security Training

EIV system users and O/A staff who do not have access to the EIV system but who use EIV reports to perform their job function are required by Housing Notice 2010-10 to complete security training annually. The Notice indicates the security training portion of HUD's most recent EIV webcast, currently December 2009, will satisfy this requirement. The Office of Multifamily Housing is introducing another available option for users to complete security awareness training. Acceptable training now includes completion of the online Federal ISS Awareness training program. The Federal ISS Awareness training program includes a *Certificate of Completion* for users to print.

To complete the Federal ISS Awareness online Security Awareness Training:

- Open your web browser.
- Type <http://iase.disa.mil/eta/index.html#onlinetraining>.
- Press Enter.
- Click on **Federal ISS Awareness** icon on the IA Education, Training and Awareness Screen.
- Click on **Launch New Information Systems Security Awareness** on the Information Systems Security Awareness screen.
- Proceed with the training.
- When the training is complete, print and maintain the *Certificate of Completion*.

Note: The Security Awareness Training described above is the same training required for those individuals who transmit TRACS files. If the training has been completed to satisfy TRACS security training requirements, this will satisfy EIV security training requirements as well so long as the completion date represented on the *Certificate of Completion* is not older than one year.

#249 - EIV System Errors/Missing Data

EIV System Errors/Missing Data

We have been advised that a number of O/As are encountering error messages and/or missing data when attempting to view EIV reports for some or all of their properties. We are aware of the error messages being displayed and are working to correct the issues in the system. O/As receiving these errors are reminded to perform third party verifications as done prior to the implementation of EIV and to retain copies of the incorrect EIV reports. We apologize for this inconvenience and will advise when the issues have been corrected.

#248 - EIV System Maintenance Scheduled

EIV System Maintenance Scheduled

Please be advised the EIV system, as with all HUD secured systems, will be down to allow for system maintenance between 9 PM EST February 18, 2011 and 7 AM EST February 22, 2011. As a result of this maintenance, the weekend summarization jobs scheduled during this time are not expected to occur.

#247 - Section 8 Policy Guides

Section 8 Renewal Guide and M2M Operating Procedures Guide Set Policy for Renewing Section 8 Project Based Contracts

The policy document for renewing Section 8 contracts not subject to restructuring is the Section 8 Renewal Guide that is posted on the HUD website at <http://www.hud.gov/offices/hsg/mfh/mfhsec8.cfm>. This Guide and the M2M Operating Procedures Guide <http://www.hud.gov/offices/hsg/omhar/mhrrroom.cfm> provide the requirements for processing projects in the Mark to Market program. Other documents, for example the iREMS User Guide, may contain information on renewing Section 8 contracts, however, statements in these documents are for information purposes only and should not be used when determining the eligibility of a project to renew its Section 8 contract.

#246 - Housing Notice 2011-01 DUNS Numbers

Notice Requiring Owners with Project-Based Rental Assistance Contracts or Section 202 or 811 Project Rental Assistance Contracts to Obtain Dun and Bradstreet Numbering System (DUNS) Numbers and to Register in the Central Contractor Registration (CCR)

Notice H 2011-01 was issued on January 5, 2011, providing the regulatory reporting requirements and guidance for legal entities receiving federal assistance. Rental assistance payments made under Project-Based Section 8 or Section 202 or 811 Project Rental Assistance Contracts are covered under these requirements. Owners must obtain a DUNS number and have an active, valid registration in CCR within 60 days of the publication date of this Notice. An owner's failure to obtain a DUNS number and CCR registration within the timeframe allotted may result in the suspension of housing assistance payments or rental assistance payments.

The notice includes guidance for the following:

- Background on Public Law 109-282, The Federal Funding Accountability and Transparency Act of 2006
- Deadline for obtaining DUNS Numbers and Registration in CCR
- Process for Obtaining a DUNS Number and Registration in CCR
- Utilization of CCR and DUNS information

The Notice is posted on HUDCLIPS

at: <http://www.hud.gov/offices/adm/hudclips/notices/hsg/>

#245 - Published: HUD Programs: Violence Against Women Act Conforming Amendments; Final Rule

**Published in the Federal Register:
HUD Programs: Violence Against Women Act Conforming Amendments; Final Rule**

HUD Programs: Violence Against Women Act Conforming Amendments; Final Rule, was published in the Federal Register on October 27, 2010. The final rule has been attached to this message and can also be found at <http://edocket.access.gpo.gov/2010/pdf/2010-26914.pdf>. The provisions in the final rule become effective November 26, 2010.

Housing notice, H09-15 *Implementation of the Violence Against Women and Justice Department Reauthorization Act of 2005 for the Multifamily Project-Based Section 8 Housing Assistance Payments Program*, is currently being revised to include the requirements found in the above mentioned final rule.

#244 - 2011 Operating Cost Adjustment Factors (OCAFs) Updated in iREMS

2011 Operating Cost Adjustment Factors (OCAFs) Updated in iREMS

The Operating Cost Adjustment Factors (OCAF) for 2011 were updated in iREMS on November 17, 2010. These factors are used for adjusting or establishing Section 8 rents under the Multifamily Assisted Housing Reform and Affordability Act of 1997 (MAHRA), as amended, for projects assisted with Section 8 Housing Assistance Payments. The factors are effective February 11, 2011 and can be found at <http://www.hud.gov/offices/hsg/mfh/mfhsec8.cfm>.

2011 Operating Cost Adjustment Factors (OCAFs) Published

The Operating Cost Adjustment Factors (OCAF) for 2011 were published in the November 8, 2010 Federal Register. These factors are used for adjusting or establishing Section 8 rents under the Multifamily Assisted Housing Reform and Affordability Act of 1997 (MAHRA), as amended, for projects assisted with Section 8 Housing Assistance Payments. The factors are effective February 11, 2011. The factors can be found at <http://www.hud.gov/offices/hsg/mfh/mfhsec8.cfm>.

**EIV Income Verification Update
SSA and NDNH Matches**

It is anticipated that a complete computer match between Multifamily Housing and the Social Security Administration will be completed by Monday, November 15, 2010. This means users may continue to get the message "A current 50059 record was not found for Social Security Number..." until November 15, 2010, because the tenant has not yet been matched with SSA.

It is also anticipated that the quarterly computer match between Multifamily Housing and the Department of Health and Human Services' National Directory of New Hires will be completed causing all tenant data originating from HHS to be available on Sunday, October 31, 2010. Please be advised only those tenants who have already been matched with SSA will appear in the EIV system.

Owners/management agents are to continue with all scheduled certifications and recertifications. If discrepant data is represented in the EIV system, traditional third party verification is to be used. As a reminder, if traditional third party verification is used, the EIV documents must still be printed and placed in the tenant file. A note indicating why the EIV data was not used must be included on the EIV printout.

Requesting Proof of Income From SSA

It has come to our attention that some owner/agents (O/As) are still advising tenants to obtain proof of their Social Security income from local Social Security Administration offices. With the Enterprise Income Verification system now providing this information, and as indicated in Housing Notice 10-10, O/As must not send tenants to local SSA offices to obtain proof of their Social Security income.

Instead, the O/A must ask the tenant to request benefit information from SSA using SSA's website or toll-free number.

To request a Proof of Income Letter from SSA's website, go to <http://www.socialsecurity.gov>. From the left side bar:

Select "What you can do online"

Select "If you get benefits"

Select "Request a Proof of Income Letter"

Tenants should check the box "All Benefit Information Available" to make sure all benefits received are provided.

To request a Proof of Income Letter from SSA's toll-free number, call 1-800-772-1213.

This information is free and the tenant should receive the letter in the mail within 10 days.

FY2011 Fair Market Rents Published in Federal Register

The final Fiscal Year (FY) 2011 Fair Market Rents (FMRs) have been published in the *Federal Register*. FMRs are used in project-based Section 8 programs along with other programs requiring their use. The FY 2011 FMRs can be located in the *Federal Register* at <http://edocket.access.gpo.gov/2010/pdf/2010-24465.pdf> or on the HUD website at <http://www.huduser.org/portal/datasets/fmr.html>.

#239 – TRACS Industry Group Meeting Cancellation Notice – September 30, 2010

TRACS Industry Group Meeting Cancellation Notice

The Office of Multifamily Housing Programs regrets to inform you that the next TRACS Industry Group Meeting scheduled for October 27, 2010 and October 28, 2010, at HUD Headquarters, Washington, DC, will not take place.

This is due to a lack of available conference rooms in the HUD Headquarters building and the lack of available hotel rooms in the Washington metropolitan area during October 27 and 28th.

Multifamily Housing apologizes for any inconvenience this may cause you and intends to reschedule the TRACS Industry Group Meeting for a later date. Full details will be published when they become available.

#238 – EIV System Fixes and Enhancements – September 24, 2010

EIV System Fixes and Enhancements

The most current release of HUD's Enterprise Income Verification system will be ready for use on **September 27, 2010**.

This release will cure all of the known issues experienced since the April release as well as the following enhanced features:

1. The Income Report will be able to be printed by individual family member in addition to the entire family.
2. The Income Discrepancy Report will include a pop-up feature to indicate what income sources are being captured.
3. The User Certification Report will now include property names next to the contract/project number for HSC and CAC users.

We have been advised there is a problem with the Security Awareness Training Questionnaire having an incorrect date after completion. This issue will be corrected in the next EIV release, however, the issue has no effect on the system or its use and a printed questionnaire is not required by HUD.

Although it is not expected that there will be any problems as a result of this release, if you should experience any problems, please submit a detailed explanation of the problem with a screen shot(s) if possible to Mf_EIV_Comments@hud.gov.

The Department encourages you to recommend any changes or enhancements that would improve the use of the EIV system. If you have any such changes or enhancements, please submit them to Mf_EIV_Comments@hud.gov.

#237 – Optional Smoke-Free Housing Policy Implementation Notice 10-21 Posted To HUDCLIPS – September 17, 2010

Optional Smoke-Free Housing Policy Implementation Notice 10-21 Posted To HUDCLIPS

Housing Notice H10-21, *Optional Smoke-Free Housing Policy Implementation*, has been signed and posted to HUDCLIPS and is located at http://portal.hud.gov/portal/page/portal/HUD/program_offices/administration/hudclips/notices/hsg/files/10-21hsgn.pdf.

This Notice encourages owners and management agents participating in one of Multifamily Housing rental assistance programs to adopt smoke-free housing policies and provides instructions on implementing these policies

#236 – Revision to New Section 8 Renewal Guide Page Changes –September 17, 2010

Revision to New Section 8 Renewal Guide Page Changes

Section 6-3 of the draft Section 8 Renewal Guide page changes has been revised since the original posting in July 2010. The entire document, including the revised Section 6-3 is posted for comment on the HUD Website at <http://www.hud.gov/offices/hsg/mfh/mfhsec8.cfm>. Comments must be identified by specific page and paragraph reference. Comments may be submitted by email to Section8RenewalGuide@hud.gov or by overnight mail to:

Department of Housing and Urban Development
Attention: Section 8 Renewal Guide
Room 6134
451 7th Street SW
Washington, DC 20410

In addition, please note that the Federal Register Notice has yet to be published; however, Multifamily Housing expects the Notice to be published in the near future.

**#235 – Advance Notice that New Section 8 Page Changes are Posted for Public Comment–
July 23, 2010**

**Advance Notice that New Section 8 Renewal Guide Page Changes are Posted for Public
Comment**

The draft page changes to the Section 8 Renewal Guide have been posted for comment on the HUD Website at <http://www.hud.gov/offices/hsg/mfh/mfhsec8.cfm> and will remain posted on the website for 10 business days after the publication of the Federal Register Notice. Comments are due to HUD 20 business days after the publication of the Federal Register Notice and must be identified by specific page and paragraph reference. Comments may be submitted by email to Section8RenewalGuide@hud.gov or by overnight mail to:

Department of Housing and Urban Development
Attention: Section 8 Renewal Guide
Room 6134
451 7th Street SW
Washington, DC 20410

EIV Notice H10-10 Posted TO HUDCLIPS

Housing Notice H10-10, *Enterprise Income Verification (EIV) System*, has been signed and posted to HUDCLIPS and is located at http://portal.hud.gov/portal/page/portal/HUD/program_offices/administration/hudclips/notices/hsg. This Notice revises Housing's previous EIV Notice H09-20.

Questions regarding the content of this Notice can be sent to MF_EIV_Comments@hud.gov.

#233 – Clarification: New Affirmative Fair Housing Marketing Plan (AFHMP) – June 30, 2010

Clarification – no change to current policy

**New Affirmative Fair Housing Marketing Plan (AFHMP)
Form HUD-935.2A**

Effective May 1, 2010, a new version of the Affirmative Fair Housing Marketing Plan (AFHMP) Plan was implemented. When an owner/agent is required to submit a new AFHMP (**currently required to review and/or up update the plan at least every 5 years – no change to current policy**), the new version of the AFHMP (form HUD-935.2A) must be submitted. The latest version of form HUD-935.2A is posted on HUDclips and can be downloaded at the following website: <http://www.hud.gov/offices/adm/hudclips/forms/files/935-2a.pdf>. Please be advised that the previous edition of form HUD-935 will no longer be accepted.

#232 –New Affirmative Fair Housing Marketing Plan (AFHMP) – June 30, 2010

**New Affirmative Fair Housing Marketing Plan (AFHMP)
Form HUD-935.2A**

Effective May 1, 2010, a new version of the Affirmative Fair Housing Marketing Plan (AFHMP) Plan was implemented. When an owner/agent is required to submit a new AFHMP (once every 5 years), the new version of the AFHMP (form HUD-935.2A) must be submitted. The latest version of form HUD-935.2A is posted on HUDclips and can be downloaded at the following website: <http://www.hud.gov/offices/adm/hudclips/forms/files/935-2a.pdf>. Please be advised that the previous edition of form HUD-935 will no longer be accepted.

#231 – Thank You to Those Who Responded – June 16, 2010

**Thank You to Those Who Responded
To RHIP Listserv #229**

In RHIP Listserv Posting #229 we requested that Multifamily users of the EIV system assist us in our effort to detect all problems with the functionality of the EIV system since it came back online. We would like to thank you for your response to this request.

Please be advised that we will respond to the email messages received in response to RHIP Listserv #229 that have requested assistance; however, responses will take some time due to the number of requests received. If you have specific access related issues please contact the Multifamily Help Desk at (800) 767-7588 or Mf_eiv@hud.gov.

Some common issues we are currently aware of and are working to correct include:

- All Income Detail Reports showing error message.
- New Hires Detail Report showing error message.
- Error message stating: No Contracts are currently assigned to you for viewing monthly Social Security and Supplemental Security Income reports.
- Error messages that include the code “500”, the words “Null Pointer Exception”, “EIV Application Error Message”, and system timeout errors.
- User Passwords not being recognized
- Delays in Social Security amounts being displayed

If you experience issues other than those identified above, please send an email to Michael Sharkey at michael.a.sharkey@hud.gov. Please be sure to include the User ID of the individual experiencing the problem and screenshots. Screenshots are extremely important in helping to troubleshoot the issues.

Several users have asked for clarification regarding the Medicare amounts represented in the EIV system. Some users are indicating the cents are being left off of this figure as well. Because Housing Notice 09-20 indicates that the O/A will use the EIV Income Report as the third party verification that the tenant is receiving SS benefits and the gross benefit amount from the Income Report for calculating the tenant’s income, the user can use the amount represented in EIV. If the tenant disputes the amounts on the EIV Income Report, the O/A should notate this on the EIV Income Report and use the Social Security Award Letter to calculate so long as this award letter is not older than 120 days. Please refer to Notice 09-20 for instructions when the tenant does not have their Social Security Award Letter or it is older than 120 days.

2010 Census

What information can be provided to census takers?

Article I, Section 2 of the Constitution of the United States calls for an actual enumeration of the people every ten years to be used for appointment of seats in the House of Representatives among the states. In March 2010, census takers began going to addresses across the country to count the population and to collect information for the 2010 Census.

Census takers are required to contact occupied apartments themselves; however, if an apartment is vacant or if the census taker is unable to contact the tenant, the census taker is instructed to ask an apartment owner/manager to answer a few short questions about the apartment (e.g. who was occupying the unit on April 1, 2010), as well as provide the name and phone number of the apartment owner/manager in the event that the Census Bureau needed to ask any follow-up questions.

In accordance with 13 USC 223 (shown below), owners and/or managers of Multifamily Housing properties **must provide census takers with the names of tenants residing in their property** when requested by a census taker. If the census taker needs information past the names of the tenants, they should request this information from HUD. Detailed information outside of the law below has to be requested from HUD as outlined in the Federal Privacy Act, as HUD is authorized to provide the detailed information maintained in a system of records (as defined by the Privacy Act). Because there are no Privacy Act implications, owners and/or managers could also provide information on what units were vacant. Property owners/managers are not authorized to disclose additional information.

In addition, Contract Administrators (CAs) of HUD Multifamily programs must not provide any tenant information to census takers. If contacted, CAs should refer the census taker to the owner or manager of the property.

§ 223. Refusal, by owners, proprietors, etc., to assist census employees

Whoever, being the owner, proprietor, manager, superintendent, or agent of any hotel, apartment house, boarding or lodging house, tenement, or other building, refuses or willfully neglects, when requested by the Secretary or by any other officer or employee of the Department of Commerce or bureau or agency thereof, acting under the instructions of the Secretary, to furnish the names of the occupants of such premises, or to give free ingress thereto and egress there from to any duly accredited representative of such Department or bureau or agency thereof, so as to permit the collection of statistics with respect to any census provided for in subchapters I and II of chapter 5 of this title, or any survey authorized by subchapter IV or V of such chapter insofar as such survey relates to any of the subjects for which censuses are provided by such subchapters I and II, including, when relevant to the census or survey being taken or made, the proper and correct enumeration of all persons having their usual place of abode in such premises, shall be fined not more than \$500.

#229 – Experiencing Problems with EIV? – June 11, 2010

Experiencing Problems with EIV?

We are asking Multifamily Program users of the EIV system to assist us in our effort to detect and correct all problems with the functionality of the EIV system since it came back online. If you experience any data anomalies or other functionality issues during your use of the system, please send a description of the problem, what report was run and for what property as well as a screenshot, if possible, to Michael Sharkey at michael.a.sharkey@hud.gov. This will help the EIV team troubleshoot, as well as provide a permanent fix, for any anomalies that may be occurring.

Please be advised that the cents being left off of SSA income is not an anomaly; this is the amount transmitted by SSA and is to be used for SSA income calculation.

Thank you for your assistance and continued patience in this process.

#228 – Notice From PIH REAC – June 10, 2010

**Notice From PIH REAC
This Will Affect Multifamily Housing Users**

Attention FASSPHA, FASSFHA, EIV, MAPS, MASS, NASS, PASS, PIC, SAGIS and VMS Users.

Portions of these application may be unavailable from **Friday 9pm EDT June 11th 2010** until **Monday 7am EDT June 14th 2010** for System Maintenance.

#227 – Use of EIV Must be Resumed by Multifamily Users – June 8, 2010

**Use of EIV
Must be Resumed by Multifamily Program Users**

Please be advised that Multifamily Program users must resume use of EIV in its entirety effective immediately. All Income Summary Reports are available to meet requirements for EIV use as defined by the Final Rule effective January 31, 2010.

At this time, the Income Detail Reports remain unavailable. Users will experience an error message should they attempt to access these reports. These reports are not necessary to complete tenant third party income verifications as the Income Summary Reports by individual will provide the tenant income data.

Please note, users may receive a “Closed Connection” message when they attempt to login to EIV during peak periods due to limited system resources. Should this occur, users should wait a few moments and attempt to login again. Issues with the Detail Reports and connectivity should be resolved no later than September 2010.

Thank you again for your patience during the EIV system upgrade. We will keep you informed of any new developments with the system.

#226 – Choice Neighborhoods FY 2010 NOFA Pre-Notice Posted – June 3, 2010

Choice Neighborhoods FY 2010 NOFA Pre-Notice Posted

HUD has posted its Choice Neighborhoods FY 2010 Notice of Funding Availability (NOFA) Pre-Notice at <http://www.hud.gov/offices/pih/programs/ph/cn/> to give potential applicants guidance before the NOFA is released this summer. Entities eligible to apply for the Choice Neighborhoods Initiative (CNI) competitive grants are local governments, public housing agencies (PHAs), nonprofits, and for-profit developers applying jointly with a public entity. There is \$65 million available for the pilot year of the program.

CNI's goal is to transform extremely poor neighborhoods into functioning, sustainable mixed-income neighborhoods with appropriate services, schools, public assets, transportation, and access to jobs. CNI grants will primarily fund the preservation, rehabilitation, and transformation of public and HUD-assisted housing. The program builds on the success of HOPE VI with a broader approach to concentrated poverty.

Grant funds can be used for resident and community services, community development and affordable housing activities in surrounding communities, and multifamily or single-family property disposition, including the conversion of these properties to affordable housing. The program will also implement rent and work incentives to help public and HUD-assisted housing resident's access jobs and move to self-sufficiency.

#225 – EIV Update - System Again Unavailable – May 26, 2010

EIV Update – System Again Unavailable

The link for the EIV system has been deactivated due to the inaccuracy of the displayed data. As indicated in Listserv Posting #224, please continue to perform third party verifications as done previous to the implementation of EIV. Continue to document the tenant files that have been affected by this outage. Contract Administrators are instructed not to issue MOR Findings due to an O/A not using EIV until such time when the system becomes fully functional.

EIV Link Activated for Multifamily Users

Please be advised that the link to the EIV system has been activated for Multifamily users. We have been told there are several data anomalies that are currently being experienced by users. Until a Listserv message is issued advising users that the system is fully functional, O/As should continue to perform third party verifications as done previous to the implementation of EIV. Please document the tenant files that have been affected by this outage. Contract Administrators are instructed not to issue MOR Findings due to an O/A not using EIV until such time when the system becomes fully functional.

Thank you again for your patience.

#223 – FY2010 Income Limits Published in Federal Register – May 17, 2010

FY2010 Income Limits Published in Federal Register

As indicated in RHIP Listserv # 222, HUD has released its FY2010 Median Family Income estimates and FY2010 Income Limits. Final Notice on Ending the “Hold-Harmless” Policy in Calculating Section 8 Income Limits Under the United States Housing Act of 1937, was published in the Federal Register today and can be found at <http://edocket.access.gpo.gov/2010/pdf/2010-11638.pdf>. Please note the link to the public preview copy of the notice which was provided in Listserv # 222 is no longer operable.

FY2010 Income Limits Released

HUD has released its FY2010 Median Family Income estimates and FY2010 Income Limits.

New for FY2010, HUD has removed its “Hold-Harmless” provisions used in the calculation of Section 8 Income Limits. HUD solicited comments on its intentions to remove this policy and the official publication of the Federal Register notice containing HUD’s responses to these comments will be published on Monday May 17, 2010. A public preview copy of the notice is available at http://www.federalregister.gov/OFRUpload/OFRData/2010-11638_PI.pdf. This notice, along with all of HUD’s FY2010 Income Limits materials, is available at <http://www.huduser.org/portal/datasets/il.html>.

Update on EIV

The Enterprise Income Verification (EIV) system remains unavailable at this time. We have been advised the problem has been diagnosed and a solution is currently being worked on. The system is expected to be available soon and a listserv message will be distributed when we have been advised that the EIV system is fully functional. When the EIV system becomes functional once again, you will notice the following enhancements:

Function	Description
Income Information	
Income Reports (By Contract Number, By Project Number)	<ul style="list-style-type: none">Added the Unit code to the unit address for all Households where unit address is available.
Verification Reports	
Multiple Subsidy Report	<ul style="list-style-type: none">Added Instructions to the Multiple Subsidy page telling users to perform both searches (one within MF and one within PIH programs).Added the Unit code to the unit address for all Households where unit address is availableAdded a link to the Head of Household SSN in the Multiple Subsidy Summary page, displaying the existing tenant search like report for the Household.Subsidy Type has been added
Existing Tenant Search Report	<ul style="list-style-type: none">Added the Unit code to the unit address for all Households where unit address is available.
Identity Verification Report	<ul style="list-style-type: none">Removed the statistics from the external users' Identity Verification Report screen. The report only displays links for Failed EIV Pre-screening and Failed Verification Report (Failed SSA Identity Test).
Security Test Module	
ALL MF External Users	<ul style="list-style-type: none">Added functionality by which, effective with the EIV 9.1 release, all users who are nearing the anniversary date of the last security test will have 30 days to take and pass the security test. During the 30-day period, when logging in, users will be reminded to take the test.Users will need to take the test once a year.New users will have to pass the test before accessing EIV.If a user fails to pass the exam on any attempt, a help feature is provided to find the answers and a link to retake the test.

April 2010 Mandatory Use of EIV Final Rule Webcast Posted

The Mandatory Use of EIV Final Rule webcast that took place April 14, 2010, which discussed Housing Notice 10-08 Refinement of Income and Rent Determination Requirements in Public and Assisted Housing Programs: Implementation of the Enterprise Income Verification System – Amendments; Final Rule, has been posted to HUD's webcasts page at <http://portal.hud.gov/portal/page/portal/HUD/webcasts/archives>. The supplemental PowerPoint slides have been posted to the Multifamily EIV website at <http://www.hud.gov/offices/hsg/mfh/rhiip/eiv/eivtraining.cfm>.

EIV System Remains Unavailable

We have been advised by HUD's Real Estate Assessment Center (REAC) that the EIV system remains unavailable. Although access to the system may be obtained, the data found in the system may not be accurate. As soon as the system becomes fully functional, we will send out a message. Until the system becomes fully functional, O/As should perform third party verifications as done previous to the implementation of EIV. Please document the tenant files that have been affected by this outage. An example of acceptable documentation would be to include a copy of this RHIP Listserv message in the tenant file. We again apologize for this inconvenience.

#219 – EIV System Remains Unavailable – April 27, 2010

EIV System Remains Unavailable

We have been advised by HUD's Real Estate Assessment Center (REAC) that the EIV system remains unavailable. Although access to the system may be obtained, the data found in the system may not be accurate. As soon as the system becomes fully functional, we will send out a message. Until the system becomes fully functional, O/As should perform third party verifications as done previous to the implementation of EIV. We again apologize for this inconvenience.

#218 – EIV System Unavailable Until 4-26-2010 – April 21, 2010

EIV System Unavailable Until April 26, 2010

We have been advised by HUD's Real Estate Assessment Center (REAC) that the EIV system will be unavailable until April 26, 2010. REAC continues to troubleshoot the server problem and has taken EIV offline. As soon as the system becomes available, we will send out a message. We again apologize for this inconvenience.

#217 – EIV is Temporarily Unavailable – April 20, 2010

EIV is Temporarily Unavailable

HUD's Real Estate Assessment Center (REAC) is trouble shooting a server problem and has taken EIV offline. As soon as the system becomes available again, we will send out a message. We apologize for this inconvenience.

#216 – EIV 9.1 Release, What's New in 9.1 and Summarization Report Reminder – April 19, 2010

SUCCESSFUL RELEASE OF EIV 9.1

EIV System 9.1 was successfully released over the weekend. At this time, all servers that handle the EIV system are not operational which is resulting in some users receiving the error message below. Multiple attempts to log into the system may result in you reaching an operational server. To do this your browser must be completely closed and reopened after each attempt. HUD hopes to have this problem corrected very soon. We apologize for any inconvenience this may cause.

HTTP Status 500 -

type Exception report

message

descriptionThe server encountered an internal error () that prevented it from fulfilling this request.

exception

There is no Action mapped for namespace / and action name selectuser. - [unknown location]

note [The full stack traces of the exception and its root causes are available in the Sun GlassFish Enterprise Server v2.1.1 logs.](#)

Sun GlassFish Enterprise Server v2.1.1

WHAT'S NEW IN THE EIV SYSTEM 9.1 RELEASE

Multifamily Housing Functionalities

Any questions related to Multifamily Housing in EIV should be directed to the Multifamily helpdesk at **1-800-767-7588** or by email at **mf_eiv@hud.gov**.

Function	Description
Income Information	
Income Reports (By Contract Number, By Project Number)	<ul style="list-style-type: none">Added the Unit code to the unit address for all Households where unit address is available.
Verification Reports	
Multiple Subsidy Report	<ul style="list-style-type: none">Added Instructions to the Multiple Subsidy page telling users to perform both searches (one within MF and one within PIH programs).Added the Unit code to the unit address for all Households where unit address is availableAdded a link to the Head of Household SSN in the Multiple Subsidy Summary page, displaying the existing tenant search

Function	Description
	like report for the Household. <ul style="list-style-type: none"> Subsidy Type has been added
Existing Tenant Search Report	<ul style="list-style-type: none"> Added the Unit code to the unit address for all Households where unit address is available.
Identity Verification Report	<ul style="list-style-type: none"> Removed the statistics from the external users' Identity Verification Report screen. The report only displays links for Failed EIV Pre-screening and Failed Verification Report (Failed SSA Identity Test).
Security Test Module	
ALL MF External Users	<ul style="list-style-type: none"> Added functionality by which, effective with the EIV 9.1 release, all users who are nearing the anniversary date of the last security test will have 30 days to take and pass the security test. During the 30-day period, when logging in, users will be reminded to take the test. Users will need to take the test once a year. New users will have to pass the test before accessing EIV. If a user fails to pass the exam on any attempt, a help feature is provided to find the answers and a link to retake the test.

Reminder: Batch Income and Verification Reports Temporarily Unavailable

As a reminder, due to the deployment of EIV Release 9.1 that took place over the weekend, the summarization job that usually runs over the weekend was not run. Therefore, the batch income reports and verification reports will not be available from April 19, 2010, until April 26, 2010.

The following reports will have no data from April 19, 2010, until April 26, 2010:

- Income Reports by Recertification Month
- Income Discrepancy
- New Hires
- Identity Verification
- Deceased Tenants
- Multiple Subsidy

During this time, access to individual income reports will still be available.

The batch reports will again be available beginning April 26, 2010. We apologize for any inconvenience this may cause.

Final Rule Notice Posted to HUDCLIPS

Housing Notice H10 – 08, *Implementation of Refinement of Income and Rent Determination Requirements in Public and Assisted Housing Programs: Implementation of the Enterprise Income Verification System - Amendments; Final Rule*, has been signed and posted to HUDCLIPS. This Notice is located at http://portal.hud.gov/portal/page/portal/HUD/program_offices/administration/hudclips/notices/hsg/files/10-08hsgn.pdf.

Reminder

Final Rule Webcast Today

The Refinement of Income and Rent Determination Requirements in Public and Assisted Housing Programs: Implementation of the Enterprise Income Verification System – Amendments; Final Rule webcast will be held today, April 14, 2010, at 1:00 PM EST (DST). This webcast will include a question and answer session. The webcast will be archived and also available for live viewing through HUD's webcasts page at <http://www.hud.gov/webcasts/index.cfm>.

Reminder

April 14, 2010 Final Rule Webcast

Questions Requested

The Refinement of Income and Rent Determination Requirements in Public and Assisted Housing Programs: Implementation of the Enterprise Income Verification System – Amendments; Final Rule webcast is scheduled for April 14, 2010, at 1:00 PM EST (DST). This webcast will include a question and answer session. Owners and agents, contract administrators and HUD staff are invited to submit their questions regarding the Final Rule prior to the webcast. As many questions as possible will be addressed during the webcast. Any questions not addressed during the webcast will be addressed either by email or in a questions and answers document that will be posted after the webcast on the EIV website at <http://www.hud.gov/offices/hsg/mfh/rhiip/eiv/eivhome.cfm>.

Questions should be sent via email to mf_eiv_comments@hud.gov and be identified by “Questions for Final Rule Webcast” in the subject line. The webcast will be archived and available for viewing through HUD’s webcasts page at <http://www.hud.gov/webcasts/index.cfm>.

Impact of EIV Release 9.1

Batch Income and Verification Reports will be Temporarily Unavailable

Due to the deployment of EIV Release 9.1 over the weekend of April 16, 2010, the summarization job that usually runs over the weekend will not run. Therefore, the batch income reports and verification reports will not be available from April 19, 2010, until April 26, 2010. Owners and management agents are advised to run all batch income reports and verification reports by no later than 8 PM EST on April 16, 2010.

The following reports will have no data from April 19, 2010, until April 26, 2010:

- Income Reports by Recertification Month
- Income Discrepancy
- New Hires
- Identity Verification
- Deceased Tenants
- Multiple Subsidy

During this time, access to individual income reports will still be available.

The batch reports will again be available beginning April 26, 2010. We apologize for any inconvenience this may cause.

April 14, 2010 Final Rule Webcast

Questions Requested

The Refinement of Income and Rent Determination Requirements in Public and Assisted Housing Programs: Implementation of the Enterprise Income Verification System – Amendments; Final Rule webcast is scheduled for April 14, 2010, at 1:00 PM DST. This webcast will include a question and answer session. Owners and agents, contract administrators and HUD staff are invited to submit their questions regarding the Final Rule prior to the webcast. As many questions as possible will be addressed during the webcast. Any questions not addressed during the webcast will be addressed either by email or in a questions and answers document that will be posted after the webcast on the EIV website at <http://www.hud.gov/offices/hsg/mfh/rhiip/eiv/eivhome.cfm>. Questions should be sent to mf_eiv_comments@hud.gov. The webcast will be archived and available for viewing through HUD's webcasts page at <http://www.hud.gov/webcasts/index.cfm>.

Final Rule Webcast to be Held on April 14, 2010

The instructional webcast on the Refinement of Income and Rent Determination Requirements in Public and Assisted Housing Programs; Final Rule making the Enterprise Income Verification (EIV) system mandatory which was tentatively scheduled for March 31, 2010, has been postponed. The new date for this webcast is **April 14, 2010, from 1:00 PM to 3:00 PM EST**. The notice which provides guidance on this final rule is still in the clearance process thus causing the postponement.

February 25, 2010 EIV Q&A Webcast Posted

The Enterprise Income Verification (EIV) 8.1.2/9.0 Question and Answer webcast that took place on February 25, 2010, has been posted to HUD's archived webcasts page at <http://portal.hud.gov/portal/page/portal/HUD/webcasts/archives>. Owners and management agents (O/As), contract administrators, and HUD staff are invited to view this webcast at their convenience. The slides from this webcast will not be posted but the questions on the slides will be included in a questions and answers document listing all of the questions submitted with their answers. A future RHIP Listserv message will be sent when this document is available.

#211 – Important Information for SAVE Users – March 23, 2010

Important Information for SAVE Users!

The Department of Homeland Security (DHS) has streamlined the Systematic Alien Verification for Entitlements (SAVE) database. Beginning on **May 1, 2010**, you must have an updated ID and password to access the SAVE system

UNLESS

you already received a User ID and temporary Password since June 2009 from HUD. If so, no further action on your part is required.

Please DO NOT call or email HUD to verify that your ID and password are okay.

SAVE is a web-based automated verification system owned by DHS that consists of immigration status verification information. Authorized users of HUD's Enterprise Income Verification (EIV) system who are also authorized to use the SAVE system are now able to access SAVE from EIV.

Owners and management agents **must** use the SAVE system to verify the validity of citizenship documents provided by applicants or tenants who are noncitizens and who claim eligible immigration status. This is to ensure that HUD's rental assistance is provided only to eligible noncitizens. For reference, see Chapter 3, Paragraph 3-12.L of HUD Handbook 4350.3 REV-1, *Occupancy Requirements of Multifamily Subsidized Housing Programs*.

Last year, DHS streamlined the SAVE database and provided HUD with a one-time opportunity to ensure that one person at each of its assisted properties has access to the SAVE system. Any additional or new staff as well as staff that did not respond to the data upload request must respond now if they did not receive a User ID or temporary Password since June 2009, or starting on May 1, 2010, they will not be able to access the SAVE system.

What you must do to gain access!

If you do not have access to SAVE or have access and did **NOT** receive a new User ID and temporary Password since June 2009, please:

- 1) Send property, name, address, fax and phone number by email to: Kevin.X.Garner@hud.gov
- 2) The deadline for submission is **April 15, 2010**.

Already have access to SAVE?

As long as the person who has current access to SAVE was given an ID and temporary Password since June 2009, nothing else needs to be done. If not, the information requested above, must be sent in by **April 15, 2010**, in order to receive a new User ID and temporary Password by April 30, 2010.

Need more than one person to have access to SAVE?

Follow the instructions under "*What you must do to gain access!*" above.

If you have any questions regarding this listserv message you may contact Kevin Garner at Kevin.X.Garner@hud.gov.

Waivers to the Section 8 Regulations and the Section 8 Renewal Guide

The Department is committed to preserving the existing stock of affordable housing and will permit the local HUD office to request waivers to certain sections of the HUD Regulations and the Section 8 Renewal Guide.

Headquarters will consider the following Field Office requests on behalf of owners:

- Regulatory Waivers
 - 880.205(a), 881.205(a), or 883.306(a) to allow a nonprofit owner with a new regulation Section 8 contract to receive distributions.

- Section 8 Renewal Guide Waivers
 - The Note found after Section 3-2D that restricts rents to use restricted levels.
 - In Chapter 15:
 - the requirement in Section 15-8 that rents in a RCS reflect use restrictions on the property;
 - the requirement in Section 15-13 that the property have a REAC score of greater than 30, and
 - the prohibitions against for-profit owners who wish to comply with the requirements of Chapter 15 from obtaining the benefits under the chapter.

In order for the waiver to be approved by Headquarters, the Hub Director must approve the request and submit it, along with certain other material; including: the major features of the transaction, specific provisions to be waived, proposed sources of financing, proposed ownership changes, timing of the transaction, and how the waiver would facilitate the preservation of the project. The information from the Hub should also indicate if any related requests have been or will be submitted to allow for prepayment of the existing mortgage, decoupling of the Interest Reduction Payments, or deferral of flexibility subsidy loans.

WAIVERS WILL NOT BE ISSUED FOR TRANCTIONS THAT HAVE ALREADY CLOSED.

For further information please contact your local field office.

**Use of the Enterprise Income Verification (EIV) System
Became Mandatory January 31, 2010**

Over 4,000 Contracts Still Don't Have EIV Access!

Lack of Access and Use Will Result in Penalties

**Coordinators – Submit Your Coordinator Access Authorization Form to the Multifamily Helpdesk
ASAP**

(See below for further instructions)

Use of the EIV system for Multifamily Housing Programs became mandatory on **January 31, 2010**, the effective date of the "Refinement of Income and Rent Determination Requirements in Public and Assisted Housing Programs: Implementation of the Enterprise Income Verification System – Amendments; Final Rule" published in the Federal Register on December 29, 2009 (FR-5351-F-02).

Owners and management agents who do not have access to EIV must act now by taking the steps outlined below.

Step 1: Determine EIV Role

When applying for initial EIV access rights, applicants must first decide what their role will be in EIV; whether they will be an EIV Coordinator (HSC) or an EIV User (HSU), as the application process is different depending on their role. An EIV Coordinator has the same functionality in EIV as an EIV User but also has the administrative functions of assigning access rights to EIV Users and recertifying their EIV Users on a biannual basis.

Step 2: Application Process for Coordinators

When applying for EIV access rights as an EIV Coordinator (HSC), an applicant must:

1. Be a WASS Coordinator and have an active WASS ID (M-ID) that was assigned to them by HUD, based on owner authorization;
2. Have a written owner authorization (letter of approval) to access EIV on the owner's behalf for their property(ies);
3. Complete and submit a hardcopy Coordinator Access Authorization Form (CAAF) to HUD's Multifamily Helpdesk by fax at 202-401-7984 or by email at Mf_Eiv@hud.gov. You need only fax pages 1, 2, and 5 of the CAAF. Do **not** fax the owner letters of approval with your request. Note, only one CAAF needs to be submitted per Coordinator. A separate CAAF should not be submitted for each property. The deadline for submission in order to have access to EIV by January 31, 2010, was December 15, 2009. **This deadline has passed; however, you must still submit your CAAF;**
4. Complete property assignments in EIV after receiving an approval email from the Helpdesk; and
5. Complete the EIV on-line certification process.

Step 3: Application Process for EIV Users

Users must have an active WASS ID (M-ID) in order to apply for access authorization rights to EIV. To apply for EIV access, Users will need to complete the User Access Authorization Form (UAAF) in hardcopy and submit it to their assigned EIV Coordinator for approval. The EIV Coordinator can approve and certify the EIV User and make the appropriate property assignments. UAAFs are **not** to be faxed to the Multifamily Helpdesk.

Detailed instructions for the application process which include how to apply for a WASS ID, upgrade to a WASS Coordinator role (necessary if applying as a Coordinator) and application forms for EIV Coordinators and EIV Users are located at:
<http://www.hud.gov/offices/hsg/mfh/rhiip/eiv/applyforeivaccess.pdf>

If you have any questions related to getting access to EIV, you may contact Kevin Garner on 202-402-2057 or Zeljko Jovanovic on 202-402-3157.

Reminder

Question and Answer Session to Supplement December 2009 Taped EIV Webcast

As a reminder, the live Question and Answer session to supplement the taped EIV webcast will be held on **Thursday, February 25, 2010, from 11:00 a.m. EST to 1:00 p.m. EST**. Since the Notice with implementing instructions on the Final Rule on Refinement of Income and Rent Determination Requirements in Public and Assisted Housing Programs has not been issued, the webcast will no longer cover further information on the Final Rule. A webcast dedicated to the Final Rule has been scheduled for March 31, 2010. More information will be provided in a future listserv message.

To benefit the most from the live Question and Answer session on February 25, 2010, it is strongly recommended that the webcast be viewed in its entirety and EIV Notice H09-20, *Enterprise Income Verification (EIV) System* be read prior to the Question and Answer session. The webcast can be found at <http://portal.hud.gov/portal/page/portal/HUD/webcasts/archives/multifamily> and the EIV Notice at http://portal.hud.gov/portal/page/portal/HUD/program_offices/administration/hudclips/notices/hsg/files/09-20hsgn.doc.

#208 – Withdrawal of Rescinded Regulatory Amendments Final Rule – February 16, 2010

Refinement of Income and Rent Determination Requirements in Public and Assisted Housing Programs: Implementation of the Enterprise Income Verification System – Withdrawal of Rescinded Regulatory Amendments

A final rule titled “Refinement of Income and Rent Determination Requirements in Public and Assisted Housing Programs: Implementation of the Enterprise Income Verification System – Withdrawal of Rescinded Regulatory Amendments, was published in the Federal Register on January 27, 2010.

The purpose of this final rule is only to revert the regulations found in the January 27, 2009, final rule back to their pre-January 27, 2009, content. This rule DOES NOT affect the regulation changes found in the Final Rule published in the Federal Register on December 29, 2009.

The subject final rule is attached and can also be found at <http://edocket.access.gpo.gov/2010/pdf/2010-1637.pdf>.

**Use of the Enterprise Income Verification (EIV) System
Became Mandatory January 31, 2010**

If you are an Owner or Management Agent (O/A) of a property that is HUD-assisted, and you do not yet have access to the EIV system, you will be contacted by either your local HUD Office or your PBCA informing you of the requirement and to submit your Coordinator Access Authorization Form (CAAF) to the Multifamily Help Desk as soon as possible. Detailed instructions for the application process which include how to apply for a WASS ID, upgrade to a WASS Coordinator role (necessary if applying as a Coordinator) and application forms for EIV Coordinators and EIV Users are located at:

<http://www.hud.gov/offices/hsg/mfh/rhiip/eiv/applyforeivaccess.pdf>

*The Multifamily Help Desk is processing CAAFs and returning phone calls as quickly as possible. Please be aware that processing of CAAFs and the return of phone calls may take longer than under normal circumstances due to the high volume of CAAFs and phone calls being received. Please **DO NOT** send your CAAF more than once or leave multiple messages since that will slow down the process. We ask that you please be patient – your CAAF will be processed and your phone call will be returned.*

Reminder

**Question and Answer Session to Supplement
December 2009 Taped EIV Webcast**

As a reminder, the live Question and Answer session to supplement the taped EIV webcast will be held on **February 25, 2010, from 11:00 a.m. EST to 1:00 p.m. EST**. This webcast will also cover the Final Rule on Refinement of Income and Rent Determination Requirements in Public and Assisted Housing Programs: Implementation of the Enterprise Income Verification System – Amendments which was published in the Federal Register on December 29, 2009, and will become effective on January 31, 2010. Slides for this portion of the webcast will be posted prior to the webcast. A listserv message will be sent as soon as the slides for this webcast are posted.

To benefit the most from the live Question and Answer session, it is strongly recommended that the webcast be viewed in its entirety and EIV Notice H09-20, *Enterprise Income Verification (EIV) System* be read prior to the Question and Answer session. In order to facilitate getting your questions answered, please submit any questions you have from viewing the webcast and/or reading Notice H09-20 to MF_EIV_Comments@hud.gov by Friday, February 12, 2010. The webcast can be found at <http://portal.hud.gov/portal/page/portal/HUD/webcasts/archives/multifamily> and the EIV Notice at http://portal.hud.gov/portal/page/portal/HUD/program_offices/administration/hudclips/notices/hsg/files/09-20hsgn.doc.

2010 IRS Standard Mileage Rates

The Internal Revenue Service has published the 2010 standard mileage rates used to calculate the deductible costs of operating an automobile for business, charitable, medical or moving purposes. These mileage rates are mentioned in Exhibit 5-3 of HUD Handbook 4350.3, REV-1 *Occupancy Requirements of Subsidized Multifamily Housing Programs* to be used when calculating a medical expense due to transportation to/from treatment and lodging.

Beginning on January 1, 2010, the standard mileage rates for the use of a car (also vans, pickups or panel trucks) will be:

- 50 cents per mile for business driven
- 16.5 cents per mile driven for medical or moving purposes
- 14 cents per mile driven in service of charitable organizations

The new rates for business, medical and moving purposes are slightly lower than last year's. The mileage rates for 2010 reflect generally lower transportation costs compared to a year ago.

For more information, please go to the IRS website at www.irs.gov.

**Use of the Enterprise Income Verification (EIV) System
Becomes Mandatory January 31, 2010**

Over 5,000 Contracts Still Don't Have EIV Access!

GET EIV ACCESS NOW (Don't Wait for a MOR Finding Which Will Result in Penalties)

**Coordinators – Submit Your Coordinator Access Authorization Form to the Multifamily Helpdesk
ASAP
(See below for further instructions)**

Use of the EIV system for Multifamily Housing Program users will become mandatory on **January 31, 2010**, the effective date of the "Refinement of Income and Rent Determination Requirements in Public and Assisted Housing Programs: Implementation of the Enterprise Income Verification System – Amendments; Final Rule" published in the Federal Register on December 29, 2009 (FR-5351-F-02).

Owners and management agents who do not have access to EIV must act now by taking the steps outlined below.

Step 1: Determine EIV Role

When applying for initial EIV access rights, applicants must first decide what their role will be in EIV; whether they will be an EIV Coordinator (HSC) or an EIV User (HSU), as the application process is different depending on their role. An EIV Coordinator has the same functionality in EIV as an EIV User but also has the administrative functions of assigning access rights to EIV Users and recertifying their EIV Users on a biannual basis.

Step 2: Application Process for Coordinators

When applying for EIV access rights as an EIV Coordinator (HSC), an applicant must:

1. Be a WASS Coordinator and have an active WASS ID (M-ID) that was assigned to them by HUD, based on owner authorization;
2. Have a written owner authorization (letter of approval) to access EIV on the owner's behalf for their property(ies);
3. Complete and submit a hardcopy Coordinator Access Authorization Form (CAAF) to HUD's Multifamily Helpdesk by fax at 202-401-7984 or by email at MF_eiv@hud.gov. You need only fax pages 1, 2, and 5 of the CAAF. Do not fax the owner letters of approval with your request. Note, only one CAAF needs to be submitted per Coordinator. A separate CAAF should not be submitted for each property. The deadline for submission in order to have access to EIV by January 31, 2010, was December 15, 2009. **This deadline has passed; however, you must still submit your CAAF;**
4. Complete property assignments in EIV after receiving an approval email from the Helpdesk; and
5. Complete the EIV on-line certification process by **January 15, 2010 (If you miss this deadline, the Multifamily Helpdesk may not be able to certify you (the last step in the approval process) by January 31, 2010.**

Step 3: Application Process for EIV Users

Users must have an active WASS ID (M-ID) in order to apply for access authorization rights to EIV. To apply for EIV access, Users will need to complete the User Access Authorization Form (UAAF) in hardcopy and submit it to their assigned EIV Coordinator for approval. The EIV Coordinator can approve and certify the EIV User and make the appropriate property assignments. UAAs are **not** to be faxed to the Multifamily Helpdesk.

**Detailed instructions for the application process which include how to apply for a WASS ID, upgrade to a WASS Coordinator role (necessary if applying as a Coordinator) and application forms for EIV Coordinators and EIV Users are located at:
<http://www.hud.gov/offices/hsg/mfh/rhiip/eiv/applyforeivaccess.pdf>**

If you have any questions related to getting access to EIV, you may contact Kevin Garner on 202-402-2057 or Zeljko Jovanovic on 202-402-3157.

#203 – EIV & You Brochure Notice Issued – January 13, 2010

EIV & You Brochure Notice Issued

Notice, H 2010-02, Enterprise Income Verification (EIV) & You Brochure – Requirements for Distribution and Use, was issued on January 11, 2010. This Notice provides instructions to owners and management agents (O/As) on the distribution and use of the *EIV & You* brochure. It is important that O/As obtain a copy of this Notice and be familiar with the contents prior to January 31, 2010, when EIV becomes mandatory. The Notice is posted on HUDCLIPS at <http://www.hud.gov/offices/adm/hudclips/notices/hsg/>.

**Use of the Enterprise Income Verification (EIV) System
Becomes Mandatory January 31, 2010**

Over 5,000 Contracts Still Don't Have EIV Access!

GET EIV ACCESS NOW (Don't Wait for a MOR Finding Which Will Result in Penalties)

**Coordinators – Submit Your Coordinator Access Authorization Form to the Multifamily Helpdesk
ASAP
(See below for further instructions)**

Use of the EIV system for Multifamily Housing Program users will become mandatory on **January 31, 2010**, the effective date of the "Refinement of Income and Rent Determination Requirements in Public and Assisted Housing Programs: Implementation of the Enterprise Income Verification System – Amendments; Final Rule" published in the Federal Register on December 29, 2009 (FR-5351-F-02).

Owners and management agents who do not have access to EIV must act now by taking the steps outlined below.

Step 1: Determine EIV Role

When applying for initial EIV access rights, applicants must first decide what their role will be in EIV; whether they will be an EIV Coordinator (HSC) or an EIV User (HSU), as the application process is different depending on their role. An EIV Coordinator has the same functionality in EIV as an EIV User but also has the administrative functions of assigning access rights to EIV Users and recertifying their EIV Users on a biannual basis.

Step 2: Application Process for Coordinators

When applying for EIV access rights as an EIV Coordinator (HSC), an applicant must:

1. Be a WASS Coordinator and have an active WASS ID (M-ID) that was assigned to them by HUD, based on owner authorization;
2. Have a written owner authorization (letter of approval) to access EIV on the owner's behalf for their property(ies);
3. Complete and submit a hardcopy Coordinator Access Authorization Form (CAAF) to HUD's Multifamily Helpdesk by fax at 202-401-7984 or by email at MF_eiv@hud.gov. You need only fax pages 1, 2, and 5 of the CAAF. Do not fax the owner letters of approval with your request. Note, only one CAAF needs to be submitted per Coordinator. A separate CAAF should not be submitted for each property. The deadline for submission in order to have access to EIV by January 31, 2010, was December 15, 2009. **This deadline has passed; however, you must still submit your CAAF;**
4. Complete property assignments in EIV after receiving an approval email from the Helpdesk; and
5. Complete the EIV on-line certification process by **January 15, 2010 (If you miss this deadline, the Multifamily Helpdesk may not be able to certify you (the last step in the approval process) by January 31, 2010.**

Step 3: Application Process for EIV Users

Users must have an active WASS ID (M-ID) in order to apply for access authorization rights to EIV. To apply for EIV access, Users will need to complete the User Access Authorization Form (UAAF) in hardcopy and submit it to their assigned EIV Coordinator for approval. The EIV Coordinator can approve and certify the EIV User and make the appropriate property assignments. UAAFs are **not** to be faxed to the Multifamily Helpdesk.

**Detailed instructions for the application process which include how to apply for a WASS ID, upgrade to a WASS Coordinator role (necessary if applying as a Coordinator) and application forms for EIV Coordinators and EIV Users are located at:
<http://www.hud.gov/offices/hsg/mfh/rhiip/eiv/applyforeivaccess.pdf>**

If you have any questions related to getting access to EIV, you may contact Kevin Garner on 202-402-2057 or Zeljko Jovanovic on 202-402-3157.

December 2009 EIV Instructional Course Posted

The Enterprise Income Verification (EIV) 8.1.2/9.0 Instructional Course webcast mentioned in Listserv messages #199 and #185 was posted to HUD's webcasts page at <http://www.hud.gov/webcasts/index.cfm> on December 31, 2009. Owners and management agents (O/As), contract administrators and HUD staff are invited to view this webcast at their convenience. The supplemental PowerPoint slides have been posted to the Multifamily EIV website at <http://www.hud.gov/offices/hsg/mfh/rhiip/eiv/eivtraining.cfm>.

Please note the posted webcast indicates a live Question and Answer session will be held on February 3rd. This session has since been rescheduled and will now be held on **February 25, 2010 from 11:00 EST to 1:00 EST**. This webcast will also cover the Final Rule on Refinement of Income and Rent Determination Requirements in Public and Assist Housing Programs. Slides for this portion of the webcast will be posted prior to the webcast. A listserv message will be sent as soon as the slides for this webcast are posted.

Published Today!

Refinement of Income and Rent Determination Requirements in Public and Assisted Housing Programs: Implementation of the Enterprise Income Verification System – Amendments; Final Rule

The Refinement of Income and Rent Determination Requirements in Public and Assisted Housing Programs: Implementation of the Enterprise Income Verification System – Amendments; Final Rule, was published in the Federal Register today, December 29, 2009. The provisions in the final rule will become **effective January 31, 2010**.

Highlights of the final rule include:

- Disclosure and verification of a Social Security Number for all applicants and tenants except those individuals who do not contend eligible immigration status or tenants who are age 62 or older as of January 31, 2010, and whose initial eligibility began prior to January 31, 2010.
- Mandatory use of the Enterprise Income Verification System (EIV).

A notice is currently being drafted which will provide instructions on the new requirements and on implementation of this final rule and is expected to be published near the time of the effective date of the rule.

The final rule is attached and can also be found at <http://edocket.access.gpo.gov/2009/pdf/E9-30720.pdf>.

REVISED EIV NOTICE ISSUED

Notice, H 09-20, Enterprise Income Verification (EIV) System, was issued on December 7, 2009. This Notice supersedes Notice H 08-03 and provides updated instructions to O/As on using the reports and data reported in EIV. It is important that O/As obtain a copy of this Notice and be familiar with the contents prior to viewing the December 2009 EIV webcast. The Notice is posted on HUDCLIPS at <http://www.hud.gov/offices/adm/hudclips/notices/hsg/>

UPDATE ON THE DECEMBER 2009 EIV WEBCAST

The EIV webcast mentioned in Listserv message #185 has been taped and will soon be posted to HUD's webcasts page at <http://www.hud.gov/webcasts/index.cfm>. A separate listserv message will be sent when the webcast and slides have been posted.

There will be a live Question and Answer session to supplement the taped webcast which will be held on **February 25, 2010 from 11:00 EST to 1:00 EST**. This webcast will also cover the Final Rule on Refinement of Income and Rent Determination Requirements in Public and Assist Housing Programs. Slides for this portion of the webcast will be posted prior to the webcast. A listserv message will be sent as soon as the slides for this webcast are posted.

DECEMBER 16-27, 2008 EIV WEBCAST REPOSTED

The December 16 and 17, 2008 EIV webcast which was taken down for updates has been reposted to HUD's webcast page at <http://www.hud.gov/webcasts/index.cfm>. A link to the webcast can also be found on the Multifamily EIV website at <http://www.hud.gov/offices/hsg/mfh/rhiip/eiv/eivtraining.cfm>.

**Resident's Rights and Responsibilities Electronic Location
Translations and English Version on One Site**

In order to provide easier access to the *Resident's Rights and Responsibilities* brochures a link to the English version has been placed on the Fair Housing and Equal Opportunity site along with the other 13 translated editions of the document. Users can go to <http://www.hud.gov/offices/fheo/promotingfh/lep.cfm> and scroll down to "*Resident's Rights and Responsibilities Brochure*." Those interested in the English version on HUD's Multifamily website can still find it at <http://www.hud.gov/groups/tenants.cfm>. Hardcopies of the English version and all of the translated versions are available from the Multifamily Housing Clearinghouse. The Clearinghouse can be reached by calling 1-800-685-8470.

**3rd REMINDER!
Use of the Enterprise Income Verification (EIV) System
Will Soon Be Mandatory!**

GET EIV ACCESS NOW (Don't Wait for a MOR Finding)

Coordinators – Submit Your Coordinator Access Authorization Form to the Multifamily Helpdesk by December 15, 2009 (See below for further instructions)

Use of the EIV system for Multifamily Housing Program users will become mandatory on **January 31, 2010**, the effective date of the "Refinement of Income and Rent Determination Requirements in Public and Assisted Housing Programs - Final Rule" published in the Federal Register on January 27, 2009 (FR-4998-F-02).

In order to meet the deadline for using EIV and to avoid penalties relating to non-compliance with the Final Rule, owners and management agents who do not have access to EIV must act now by taking the steps outlined below.

Step 1: Determine EIV Role

When applying for initial EIV access rights, applicants must first decide what their role will be in EIV; whether they will be an EIV Coordinator (HSC) or an EIV User (HSU), as the application process is different depending on their role. An EIV Coordinator has the same functionality in EIV as an EIV User but also has the administrative functions of assigning access rights to EIV Users and recertifying their EIV Users on a biannual basis.

Step 2: Application Process for Coordinators

When applying for EIV access rights as an EIV Coordinator (HSC), an applicant must:

1. Be a WASS Coordinator and have an active WASS ID (M-ID) that was assigned to them by HUD, based on owner authorization;
2. Have a written owner authorization (letter of approval) to access EIV on the owner's behalf for their property(ies);
3. Complete and submit a hardcopy Coordinator Access Authorization Form (CAAF) to HUD's Multifamily Helpdesk by fax at 202-401-7984 or by email at MF_eiv@hud.gov. You need only fax pages 1, 2, and 5 of the CAAF. Do not fax the owner letters of approval with your request. Note, only one CAAF needs to be submitted per Coordinator. A separate CAAF should not be submitted for each property. The deadline for submission in order to have access to EIV by January 31, 2010, is **December 15, 2009 (If you miss the deadline, you must still submit your CAAF – you just run the risk that it will not be processed in time for access to be granted by January 31, 2010);**
4. Complete property assignments in EIV after receiving an approval email from the Helpdesk; and
5. Complete the EIV on-line certification process by **January 15, 2010 (If you miss this deadline, the Multifamily Helpdesk may not be able to certify you (the last step in the approval process) by January 31, 2010.**

Step 3: Application Process for EIV Users

Users must have an active WASS ID (M-ID) in order to apply for access authorization rights to EIV. To apply for EIV access, Users will need to complete the User Access

Authorization Form (UAAF) in hardcopy and submit it to their assigned EIV Coordinator for approval. The EIV Coordinator can approve and certify the EIV User and make the appropriate property assignments. UAAFs are **not** to be faxed to the Multifamily Helpdesk.

Detailed instructions for the application process which include how to apply for a WASS ID, upgrade to a WASS Coordinator role (necessary if applying as a Coordinator) and application forms for EIV Coordinators and EIV Users are located at:

<http://www.hud.gov/offices/hsg/mfh/rhiip/eiv/applyforeivaccess.pdf>

If you have any questions related to getting access to EIV, you may contact Kevin Garner on 202-402-2057 or Zeljko Jovanovic on 202-402-3157.

2nd REMINDER! (with clarifying information)

**Use of the Enterprise Income Verification (EIV) System
Will Soon Be Mandatory!**

GET EIV ACCESS NOW (Don't Wait for a MOR Finding)

Use of the EIV system for Multifamily Housing Program users will become mandatory on **January 31, 2010**, the effective date of the "Refinement of Income and Rent Determination Requirements in Public and Assisted Housing Programs - Final Rule" published in the Federal Register on January 27, 2009 (FR-4998-F-02).

In order to meet the deadline for using EIV and to avoid penalties relating to non-compliance with the Final Rule, owners and management agents who do not have access to EIV must act now by taking the steps outlined below.

Step 1: Determine EIV Role

When applying for initial EIV access rights, applicants must first decide what their role will be in EIV; whether they will be an EIV Coordinator (HSC) or an EIV User (HSU), as the application process is different depending on their role. An EIV Coordinator has the same functionality in EIV as an EIV User but also has the administrative functions of assigning access rights to EIV Users and recertifying their EIV Users on a biannual basis.

Step 2: Application Process for Coordinators

When applying for EIV access rights as an EIV Coordinator (HSC), an applicant must:

1. Be a WASS Coordinator and have an active WASS ID (M-ID) that was assigned to them by HUD, based on owner authorization;
2. Have a written owner authorization (letter of approval) to access EIV on the owner's behalf for their property(ies);
3. Complete and submit a hardcopy Coordinator Access Authorization Form (CAAF) to HUD's Multifamily Helpdesk by fax at 202-401-7984 or by email at MF_eiv@hud.gov. You need only fax pages 1, 2, and 5 of the CAAF. Do not fax the owner letters of approval with your request. Note, only one CAAF needs to be submitted per Coordinator. A separate CAAF should not be submitted for each property. The deadline for submission in order to have access to EIV by January 31, 2010, is **December 15, 2009 (If you miss the deadline, you must still submit your CAAF – you just run the risk that it will not be processed in time for access to be granted by January 31, 2010;**
4. Complete property assignments in EIV after receiving an approval email from the Helpdesk; and
5. Complete the EIV on-line certification process **by January 15, 2010 (If you miss this deadline, the Multifamily Helpdesk may not be able to certify you (the last step in the approval process) by January 31, 2010.**

Step 3: Application Process for EIV Users

Users must have an active WASS ID (M-ID) in order to apply for access authorization rights to EIV. To apply for EIV access, Users will need to complete the User Access Authorization Form (UAAF) in hardcopy and submit it to their assigned EIV Coordinator for approval. The EIV Coordinator can approve and certify the EIV User and make the appropriate property assignments. UAAFs are not to be faxed to the Multifamily Helpdesk.

Detailed instructions for the application process which include how to apply for a WASS ID, upgrade to a WASS Coordinator role (necessary if applying as a Coordinator) and application forms for EIV Coordinators and EIV Users are located at:
<http://www.hud.gov/offices/hsg/mfh/rhiip/eiv/applyforeivaccess.pdf>

If you have any questions related to getting access to EIV, you may contact Kevin Garner on 202-402-2057 or Zeljko Jovanovic on 202-402-3157.

REMINDER!

**Use of the Enterprise Income Verification (EIV) System
Will Soon Be Mandatory!**

GET EIV ACCESS NOW

Use of the EIV system for Multifamily Housing Program users will become mandatory on **January 31, 2010**, the effective date of the "Refinement of Income and Rent Determination Requirements in Public and Assisted Housing Programs - Final Rule" published in the Federal Register on January 27, 2009 (FR-4998-F-02).

In order to meet the deadline for using EIV and to avoid penalties relating to non-compliance with the Final Rule, owners and management agents who do not have access to EIV must act now by taking the steps outlined below.

Step 1: Determine EIV Role

When applying for initial EIV access rights, applicants must first decide what their role will be in EIV; whether they will be an EIV Coordinator (HSC) or an EIV User (HSU), as the application process is different depending on their role. An EIV Coordinator has the same functionality in EIV as an EIV User but also has the administrative functions of assigning access rights to EIV Users and recertifying their EIV Users on a biannual basis.

Step 2: Application Process for Coordinators

When applying for EIV access rights as an EIV Coordinator (HSC), an applicant must:

1. Be a WASS Coordinator and have an active WASS ID (M-ID) that was assigned to them by HUD, based on owner authorization;
2. Have a written owner authorization (letter of approval) to access EIV on the owner's behalf for their property(ies);
3. Complete and submit a hardcopy Coordinator Access Authorization Form (CAAF) to HUD's Multifamily Helpdesk by fax at 202-401-7984 or by email at MF_eiv@hud.gov. You need only fax pages 1, 2, and 5 of the CAAF. Do not fax the owner letters of approval with your request. Note, only one CAAF needs to be submitted per Coordinator. A separate CAAF should not be submitted for each property. The deadline for submission in order to have access to EIV by January 31, 2010, is **December 15, 2009**;
4. Complete property assignments in EIV after receiving an approval email from the Helpdesk; and
5. Complete the EIV on-line certification process by **January 15, 2010**.

Step 3: Application Process for EIV Users

Users must have an active WASS ID (M-ID) in order to apply for access authorization rights to EIV. To apply for EIV access, Users will need to complete the User Access Authorization Form (UAAF) in hardcopy and submit it to their assigned EIV Coordinator for approval. The EIV Coordinator can approve and certify the EIV User and make the appropriate property assignments. UAAFs are **not** to be faxed to the Multifamily Helpdesk.

Detailed instructions for the application process which include how to apply for a WASS ID, upgrade to a WASS Coordinator role (necessary if applying as a Coordinator) and application forms for EIV Coordinators and EIV Users are located at:

<http://www.hud.gov/offices/hsg/mfh/rhiip/eiv/applyforeivaccess.pdf>

If you have any questions related to getting access to EIV, you may contact Kevin Garner on 202-402-2057 or Zeljko Jovanovic on 202-402-3157.

REMINDER!

**Use of the Enterprise Income Verification (EIV) System
Will Soon Be Mandatory!**

GET EIV ACCESS NOW

Use of the EIV system for Multifamily Housing Program users will become mandatory on **January 31, 2010**, the effective date of the "Refinement of Income and Rent Determination Requirements in Public and Assisted Housing Programs - Final Rule" published in the Federal Register on January 27, 2009 (FR-4998-F-02).

In order to meet the deadline for using EIV and to avoid penalties relating to non-compliance with the Final Rule, owners and management agents who do not have access to EIV must act now by taking the steps outlined below.

Step 1: Determine EIV Role

When applying for initial EIV access rights, applicants must first decide what their role will be in EIV; whether they will be an EIV Coordinator (HSC) or an EIV User (HSU), as the application process is different depending on their role. An EIV Coordinator has the same functionality in EIV as an EIV User but also has the administrative functions of assigning access rights to EIV Users and recertifying their EIV Users on a biannual basis.

Step 2: Application Process for Coordinators

When applying for EIV access rights as an EIV Coordinator (HSC), an applicant must:

1. Be a WASS Coordinator and have an active WASS ID (M-ID) that was assigned to them by HUD, based on owner authorization;
2. Have a written owner authorization (letter of approval) to access EIV on the owner's behalf for their property(ies);
3. Complete and submit a hardcopy Coordinator Access Authorization Form (CAAF) to HUD's Multifamily Helpdesk by fax at 202-401-7984 or by email at MF_eiv@hud.gov. You need only fax pages 1, 2, and 5 of the CAAF. Do not fax the owner letters of approval with your request. Note, only one CAAF needs to be submitted per Coordinator. A separate CAAF should not be submitted for each property. The deadline for submission in order to have access to EIV by January 31, 2010, is **December 15, 2009**;
4. Complete property assignments in EIV after receiving an approval email from the Helpdesk; and
5. Complete the EIV on-line certification process by **January 15, 2010**.

Step 3: Application Process for EIV Users

Users must have an active WASS ID (M-ID) in order to apply for access authorization rights to EIV. To apply for EIV access, Users will need to complete the User Access Authorization Form (UAAF) in hardcopy and submit it to their assigned EIV Coordinator for approval. The EIV Coordinator can approve and certify the EIV User and make the appropriate property assignments. UAAFs are **not** to be faxed to the Multifamily Helpdesk.

Detailed instructions for the application process which include how to apply for a WASS ID, upgrade to a WASS Coordinator role (necessary if applying as a Coordinator) and application forms for EIV Coordinators and EIV Users are located at:

<http://www.hud.gov/offices/hsg/mfh/rhiip/eiv/applyforeivaccess.pdf>

If you have any questions related to getting access to EIV, you may contact Kevin Garner on 202-402-2057 or Zeljko Jovanovic on 202-402-3157.

**RESIDENT RIGHTS & RESPONSIBILITIES BROCHURE AVAILABLE
IN SEVERAL LANGUAGES**

The Resident Rights & Responsibilities Brochure discussed in recent Listserv messages is available in English as well as several other languages (Amharic, Arabic, Armenian, Cambodian, Chinese, Farsi, French, Korean, Portuguese, Russian, Spanish, Tagalog and Vietnamese). The translated versions of the brochure are available on HUD's Limited English Proficiency website at: <http://www.hud.gov/offices/ftheo/promotingfh/lep.cfm>.

The English version of the brochure is available at:
<http://www.hud.gov/offices/hsg/mfh/gendocs/mfhrrr.pdf>.

Also, please see the attached letter from Carol Galante, Deputy Assistant Secretary for Multifamily Housing Programs, which reminds owners and management agents that a copy of the brochure must be provided to head of households each year at lease renewal or income recertification.

Attachment



OFFICE OF HOUSING

U.S. DEPARTMENT OF HOUSING AND URBAN DEVELOPMENT

WASHINGTON, DC 20410-8000

NOV 10 2009

Dear Owners and Managers:

I would like to take this opportunity to remind you of the importance the Department of Housing and Urban Development places on resident rights and responsibilities. As you know, the Department has published "Resident Rights and Responsibilities", a brochure that provides information and guidance for residents of HUD-assisted housing on this topic. The Department's commitment to resident participation and organization is long-standing. We believe that resident participation creates important and beneficial partnerships that can enhance project stability and improve communities.

In order to further this objective, it is necessary to ensure the widest possible distribution of the "Resident Rights and Responsibilities" brochure. This is a reminder that all owners and management agents of HUD-assisted housing must provide the brochure to head of households each year at lease renewal or income recertification. The brochure is available in thirteen languages and the version most suitable for full understanding by the household should be provided. The brochure is provided free of charge by the Department through our Multifamily Clearinghouse. Please contact the Clearinghouse at: 1-800-685-8470 to obtain copies, or you may download the brochure at <http://www.hud.gov/offices/fheo/promotingfh/lep.cfm>.

Thank you for your attention and cooperation.

Sincerely,

A handwritten signature in cursive script, appearing to read "Carol J. Galante".

Carol J. Galante
Deputy Assistant Secretary for
Multifamily Housing Programs

RESIDENT RIGHTS BROCHURE

Please read the attached letter from Carol J. Galante, Deputy Assistance Secretary for Multifamily Housing Programs, regarding the importance of providing the “Resident Rights and Responsibilities” brochure to tenants at each lease renewal or income recertification.

This requirement is also discussed in paragraph 5-15.C.2 of HUD Handbook 4350.3 REV-1, *Occupancy Requirements of Subsidized Multifamily Housing Programs.*”

The link to view the “Resident Rights and Responsibilities” brochure is:
<http://www.hud.gov/offices/hsg/mfh/gendocs/mfhrrr.pdf>

Attachment



OFFICE OF HOUSING

U.S. DEPARTMENT OF HOUSING AND URBAN DEVELOPMENT

WASHINGTON, DC 20410-8000

NOV 10 2009

Dear Owners and Managers:

I would like to take this opportunity to remind you of the importance the Department of Housing and Urban Development places on resident rights and responsibilities. As you know, the Department has published "Resident Rights and Responsibilities", a brochure that provides information and guidance for residents of HUD-assisted housing on this topic. The Department's commitment to resident participation and organization is long-standing. We believe that resident participation creates important and beneficial partnerships that can enhance project stability and improve communities.

In order to further this objective, it is necessary to ensure the widest possible distribution of the "Resident Rights and Responsibilities" brochure. This is a reminder that all owners and management agents of HUD-assisted housing must provide the brochure to head of households each year at lease renewal or income recertification. The brochure is available in thirteen languages and the version most suitable for full understanding by the household should be provided. The brochure is provided free of charge by the Department through our Multifamily Clearinghouse. Please contact the Clearinghouse at: 1-800-685-8470 to obtain copies, or you may download the brochure at <http://www.hud.gov/offices/fheo/promotingfh/lep.cfm>.

Thank you for your attention and cooperation.

Sincerely,

A handwritten signature in cursive script, appearing to read "Carol J. Galante".

Carol J. Galante
Deputy Assistant Secretary for
Multifamily Housing Programs

RESIDENT RIGHTS BROCHURE

Please read the attached letter from Carol J. Galante, Deputy Assistance Secretary for Multifamily Housing Programs, regarding the importance of providing the “Resident Rights and Responsibilities” brochure to tenants at each lease renewal or income recertification.

This requirement is also discussed in paragraph 5-15.C.2 of HUD Handbook 4350.3 REV-1, *Occupancy Requirements of Subsidized Multifamily Housing Programs.*”

Attachment



OFFICE OF HOUSING

U.S. DEPARTMENT OF HOUSING AND URBAN DEVELOPMENT

WASHINGTON, DC 20410-8000

NOV 10 2009

Dear Owners and Managers:

I would like to take this opportunity to remind you of the importance the Department of Housing and Urban Development places on resident rights and responsibilities. As you know, the Department has published "Resident Rights and Responsibilities", a brochure that provides information and guidance for residents of HUD-assisted housing on this topic. The Department's commitment to resident participation and organization is long-standing. We believe that resident participation creates important and beneficial partnerships that can enhance project stability and improve communities.

In order to further this objective, it is necessary to ensure the widest possible distribution of the "Resident Rights and Responsibilities" brochure. This is a reminder that all owners and management agents of HUD-assisted housing must provide the brochure to head of households each year at lease renewal or income recertification. The brochure is available in thirteen languages and the version most suitable for full understanding by the household should be provided. The brochure is provided free of charge by the Department through our Multifamily Clearinghouse. Please contact the Clearinghouse at: 1-800-685-8470 to obtain copies, or you may download the brochure at <http://www.hud.gov/offices/fheo/promotingfh/lep.cfm>.

Thank you for your attention and cooperation.

Sincerely,

A handwritten signature in cursive script, appearing to read "Carol J. Galante".

Carol J. Galante
Deputy Assistant Secretary for
Multifamily Housing Programs

#190 – Supersedes message #188 & #189 - EIV Use To Be Mandatory Soon! – November 19, 2009

This Listserv message supersedes messages #188 and #189.

Use of the Enterprise Income Verification (EIV) System
Will Soon Be Mandatory!

GET EIV ACCESS NOW

Use of the EIV system for Multifamily Housing Program users will become mandatory on **January 31, 2010**, the effective date of the "Refinement of Income and Rent Determination Requirements in Public and Assisted Housing Programs - Final Rule" published in the Federal Register on January 27, 2009 (FR-4998-F-02).

In order to meet the deadline for using EIV and to avoid penalties relating to non-compliance with the Final Rule, owners and management agents who do not have access to EIV must act now by taking the steps outlined below.

Step 1: Determine EIV Role

When applying for initial EIV access rights, applicants must first decide what their role will be in EIV; whether they will be an EIV Coordinator (HSC) or an EIV User (HSU), as the application process is different depending on their role. An EIV Coordinator has the same functionality in EIV as an EIV User but also has the administrative functions of assigning access rights to EIV Users and recertifying their EIV Users on a biannual basis.

Step 2: Application Process for Coordinators

When applying for EIV access rights as an EIV Coordinator (HSC), an applicant must:

1. Be a WASS Coordinator and have an active WASS ID (M-ID) that was assigned to them by HUD, based on owner authorization;
2. Have a written owner authorization (letter of approval) to access EIV on the owner's behalf for their property(ies);
3. Complete and submit a hardcopy Coordinator Access Authorization Form (CAAF) to HUD's Multifamily Helpdesk by fax at 202-401-7984 or by email at MF_eiv@hud.gov. You need only fax pages 1, 2, and 5 of the CAAF. Do not fax the owner letters of approval with your request. Note, only one CAAF needs to be submitted per Coordinator. A separate CAAF should not be submitted for each property. The deadline for submission in order to have access to EIV by January 31, 2010, is **December 15, 2009**;
4. Complete property assignments in EIV after receiving an approval email from the Helpdesk; and
5. Complete the EIV on-line certification process by **January 15, 2010**.

Step 3: Application Process for EIV Users

Users must have an active WASS ID (M-ID) in order to apply for access authorization rights to EIV. To apply for EIV access, Users will need to complete the User Access Authorization Form (UAAF) in hardcopy and submit it to their assigned EIV Coordinator for approval. The EIV Coordinator can approve and certify the EIV User and make the appropriate property assignments. UAAFs are **not** to be faxed to the Multifamily Helpdesk.

Detailed instructions for the application process which include how to apply for a WASS ID, upgrade to a WASS Coordinator role (necessary if applying as a Coordinator) and application

forms for EIV Coordinators and EIV Users are located at:

<http://www.hud.gov/offices/hsg/mfh/rhiip/eiv/applyforeivaccess.pdf>

If you have any questions related to getting access to EIV, you may contact Kevin Garner on 202-402-2057 or Zeljko Jovanovic on 202-402-3157.

#189 – Superseded by message #190

#188 – Superseded by message #190

2010 Operating Cost Adjustment Factors (OCAFs) Published

The Operating Cost Adjustment Factors (OCAF) for 2010 were published in the November 12, 2009 Federal Register. These factors are used for adjusting or establishing Section 8 rents under the Multifamily Assisted Housing Reform and Affordability Act of 1997 (MAHRA), as amended, for projects assisted with Section 8 Housing Assistance Payments. The factors are effective February 11, 2010. The factors can be found at <http://www.hud.gov/offices/hsg/mfh/mfhsec8.cfm>

**#186 – Reissuance and Clarification of VAWA Notice and No Social Security COLA in 2010
– October 30, 2009**

Reissuance and Clarification of Housing Notice on Implementation of the Violence Against Women Act (VAWA)

Notice H08-07, Implementation of the Violence Against Women and Justice Department Reauthorization Act of 2005 for the Multifamily Project-Based Section 8 Housing Assistance Payments Program, has been reissued as Notice H09-15. The name and language of the notice have not been changed.

Since the initial issuance of the Notice, there has been some misinterpretation of the VAWA requirements that needs clarification. Specifically, due to the name of the statute referencing only women, the Notice has been misinterpreted to only apply to women who are victims of domestic violence, dating violence or stalking. The statute's applicability is not gender specific and the Notice does **not** state that it applies only to women and contains several references to "he/she" when referring to the tenant as being a victim of domestic violence, dating violence or stalking.

Owners/management agents (O/As) must follow the requirements of Notice H09-15 by providing all new tenants with the applicable HUD model lease along with the VAWA Lease Addendum (Form HUD - 91067) which is an attachment to the Notice and revises the lease to reflect the VAWA requirements. O/As who haven't already done so, must also send all existing tenants a copy of the VAWA Lease Addendum (Form HUD – 91067) along with a cover letter which explains that the VAWA Lease Addendum contains important information regarding protections for victims of domestic violence, dating violence or stalking. The letter must clearly state that the tenant can either accept the modifications to the lease by signing the VAWA Lease Addendum or choose to move, which is required for any lease addendum, but that a response is due within 30 days. The VAWA Lease Addendum must be signed by every adult member of the household. Additional lines may be added to the addendum to accommodate multiple signatures.

A final point of clarification is that while the VAWA Lease Addendum must be signed by all new and existing tenants as of the effective date of the initial VAWA Notice (September 30, 2008), the Certification of Domestic Violence, Dating Violence or Stalking (Form HUD - 91066) which is also an attachment to the Notice does **not** need to be signed by every adult member of the tenant's household along with the VAWA Lease Addendum. An O/A responding to a tenant's report of an incident of actual or threatened domestic violence, dating violence, or stalking that could potentially have an impact on the tenant's participation in the Project-Based Section 8 Housing Assistance Payments Program may request that the victim complete, sign, and submit this form within 14 days of the request by the O/A. The O/A may extend this time period at his/her discretion.

Alternatively, in lieu of the certification form or in addition to it, O/As may accept:

1. A federal, state, tribal, territorial, or local police record or court record, or
2. Documentation signed and attested to by a professional (employee, agent or volunteer of a victim service provider, an attorney, medical personnel, etc.) from whom the victim has sought assistance in addressing domestic violence, dating violence or stalking or the effects of the abuse.

As a reminder, O/As are not required to demand that an individual produce official documentation or physical proof of an individual's status as a victim of domestic violence, dating violence or stalking in order to receive the protections of the VAWA.

No Social Security Cost-of-Living Adjustment (COLA) for 2010

See below SSA press release announcing that there will be no COLA for 2010.

Thursday, October 15, 2009
For Immediate Release

Mark Lassiter, Press Officer
410-965-8904
press.office@ssa.gov

SOCIAL SECURITY

News Release

Prompt Passage of Economic Recovery Act Payment for 2010 Needed

Law Does Not Provide for a Social Security Cost-of-Living Adjustment for 2010

With consumer prices down over the past year, **monthly Social Security and Supplemental Security Income benefits for more than 57 million Americans will not automatically increase in 2010.** This will be the first year without an automatic Cost-of-Living Adjustment (COLA) since they went into effect in 1975.

“Social Security is doing its job helping Americans maintain their standard of living,” Michael J. Astrue, Commissioner of Social Security said. “Last year when consumer prices spiked, largely as a result of higher gas prices, beneficiaries received a 5.8 percent COLA, the largest increase since 1982. This year, in light of the human need, we need to support President Obama’s call for us to make another \$250 recovery payment for 57 million Americans.”

The Social Security Act provides that Social Security and Supplemental Security Income benefits increase automatically each year if there is an increase in the Bureau of Labor Statistics' *Consumer Price Index for Urban Wage Earners and Clerical Workers* (CPI-W) from the third quarter of the last year to the third quarter of the current year. This year there was no increase in the CPI-W from the third quarter of 2008 to the third quarter of 2009. In addition, because there was no increase in the CPI-W this year, under the law the starting point for determinations regarding a possible 2011 COLA will remain the third quarter of 2008.

Some other changes that would normally take effect in January 2010 based on the increase in average wages also will not take effect, even though average wages did increase. Since there is no COLA, the statute prohibits an increase in the maximum amount of earnings subject to the Social Security tax as well as the retirement earnings test exempt amounts. These amounts will remain unchanged in 2010. The attached fact sheet provides more information on 2010 Social Security changes.

Information about Medicare changes for 2010, when available, will be found at www.Medicare.gov. The Department of Health and Human Services has not yet announced if there will be any Medicare premium changes for 2010. Should there be an increase in the Medicare Part B premium, the law contains a “hold harmless” provision that protects about 93 percent of Social Security beneficiaries from paying a higher Part B premium, in order to avoid reducing their net Social Security benefit. Those not protected include higher income beneficiaries subject to an income-adjusted Part B premium and beneficiaries newly entitled to Part B in 2010. On September 24th, the House passed legislation by 406-18 that would, on a fully paid-for basis, prevent abnormally large premium increases. The President is calling on the Senate to enact this legislation before it becomes too late for the Social Security Administration to update its computer systems to implement this needed change.

For additional information about the 2010 COLA, go to www.socialsecurity.gov/cola.

###

*SSA Press Office 440 Altmeyer Building 6401 Security Blvd. Baltimore, MD 21235
410-965-8904 FAX 410-966-9973*

EIV Webcast 2009

The EIV webcast that was tentatively scheduled for October 21 and 22, 2009, will not be occurring on these dates. To eliminate the numerous technical difficulties that were experienced during the webcasts in June 2007 and December 2008, the next EIV instructional course will be taped and made available online for viewing at your convenience. It is expected that the taped presentation will be posted in December 2009. Approximately one month later, a live webcast will be held to answer any questions that you may have regarding the content of the taped presentation. The date of the posting of the presentation along with the date of the live question and answer session will be confirmed in a future listserv message.

Published!

Refinement of Income and Rent Determination Requirements in Public and Assisted Housing Programs:

Implementation of Enterprise Income Verification – Proposed Amendments, Proposed Rule

A proposed rule, “Refinement of Income and Rent Determination Requirements in Public and Assisted Housing Programs: Implementation of Enterprise Income Verification – Proposed Amendments”, was published in the Federal Register today, October 15, 2009. The proposed can be found at <http://edocket.access.gpo.gov/2009/pdf/E9-24809.pdf>. Through this rule, HUD is proposing to make certain changes to the Refinement of Income and Rent Determination Requirements in Public and Assisted Housing Programs, Final Rule published in the Federal Register on January 27, 2009, and scheduled to become effective on January 31, 2010, which HUD believes will address the issues and concerns raised by the public commenters. In addition, other issues found in the Final Rule have been deferred to subsequent rulemaking. There is a 30-day public comment period on the proposed rule. HUD welcomes public comment on all aspects of the proposed rule and specifically requests comments on the proposed regulatory requirements pertaining to SSN disclosure. Public comments can be submitted by mail or electronically through the Federal eRulemaking Portal at www.regulations.gov.

**Attention: Multifamily EIV Users
Correction to Listserv Posting #182**

The following section of the Multifamily Housing EIV 9.0 Release Summary chart has been updated to correct the dates for the phase-in schedule for external users testing. Specifically, the dates for HSU users and CAU users are now correctly represented in the chart as March 01, 2010 and June 01, 2010, respectively. The entire updated chart can be found at the bottom of this message.

Phased-in Schedule for External Users Testing	<ul style="list-style-type: none">· The Security Awareness Questionnaire is being phased-in by user’s role for online completion as follows:<ul style="list-style-type: none">· HSC users upon entering EIV on the September 2009 Release date;· CAC users on or after December 01, 2009;· HSU users on or after March 01, 2010;· CAU users on or after June 01, 2010.
--	---

The Multifamily EIV system summary below that was included in Listserv #177 has been updated to indicate that the Security Awareness Testing Module is being phased in for external users and the summary includes the phase-in schedule. Until December 1, 2009, only users with the HSC role have the ability to take the Security Awareness Training Questionnaire through the EIV system. All other external users must still use the version that may be downloaded from the Multifamily EIV website at: <http://www.hud.gov/offices/hsg/mfh/rhip/eiv/securityawareness.pdf>

until such time as the Security Awareness Testing Module is available to them in the EIV system according to the schedule below.

“Multifamily Housing EIV 9.0 Release Summary - Updated”

Function	Description
EIV — Security Awareness Testing Module	
For External Users (HSC, CAC, CAU, HSU)	<ul style="list-style-type: none"> · External users need to pass this test (90% passing grade) once in a year to gain access to EIV system. · Coordinators (HSC, CAC) have 15 questions to answer. · External users (HSU, CAU) have 10 questions to answer. · The result of a user’s security test will be available to print for a year inside EIV.
Phased-in Schedule for External Users Testing	<ul style="list-style-type: none"> · The Security Awareness Questionnaire is being phased-in by user’s role for online completion as follows: <ul style="list-style-type: none"> · HSC users upon entering EIV on the September 2009 Release date; · CAC users on or after December 01, 2009; · HSU users on or after March 01, 2010; · CAU users on or after June 01, 2010.
EIV — Income Information Reports	
by Contract Number	<ul style="list-style-type: none"> · Changed the module name from By Subsidy Contract to By Contract Number. · Masked the tenant SSN (except last 4 digits) and DOB (except year) in all reports.
by Project Number	<ul style="list-style-type: none"> · Masked the tenant SSN (except last 4 digits) and DOB (except year) in all reports.
by Head of Household	<ul style="list-style-type: none"> · Masked the tenant SSN (except last 4 digits) and DOB (except year) in all reports. · Removed the Confirmation – 3rd Party Verification tab.
EIV — Verification Reports	
Deceased Tenants Report	<ul style="list-style-type: none"> · Masked the tenant SSN (except last 4 digits) and DOB (except year) in all reports. · Added date received by EIV to indicate the date EIV received the data from SSA.
Multiple Subsidy Report	<ul style="list-style-type: none"> · Masked the tenant SSN (except last 4 digits) and DOB (except year) in all reports. · New filters for searching the multiple subsidy report: <ul style="list-style-type: none"> o By all household members o Only adult household members o Only members under the age of 18
EIV- User Access Requests	
Authorization Form	<ul style="list-style-type: none"> · The Security awareness test checkbox has been removed from CAAF and UAAF forms.
EIV- External Links	
Link to DHS SAVE System	<ul style="list-style-type: none"> · A link to the Department of Homeland Security SAVE (System Alien Verification for Entitlements) system is displayed at the top.
EIV- Link to Welcome Page	

Function	Description
Back to EIV Main Page	A link back to EIV Welcome page is available from anywhere in the application.

Attachment

INSTRUCTIONS FOR TRACS FORMS POSTED ON HUDCLIPS

Instructions for completing the forms listed below have been posted on HUDCLIPS at: <http://www.hud.gov/offices/adm/hudclips/forms/>. When you go to the form number in HUDCLIPS you will now have the option to either access the form or the instructions.

For example, if you go to the form HUD-50059 in HUDCLIPS you will see the following:

HUD-50059	Owner's Certification of Compliance with HUD's Tenant Eligibility and Rent Procedures (Instructions) (Form) (09/2008)
-----------	---

Forms:

- HUD-50059, Owner's Certification of Compliance with HUD's Tenant Eligibility and Rent Procedures
- HUD-50059-A, Owner's Certification of Compliance with HUD's Tenant Eligibility and Rent procedures – Partial Certification
- HUD-52670, Housing Owner's Certification and Application for Housing Assistance Payments
- HUD-52670-A, Part 1, Schedule of Tenant Assistance Payments Due
- HUD-52670-A, Part 3, Adjustments to Schedule of Tenant Assistance Payments Due
- HUD-52670-A, Part 4, Misc. Accounting Requests for Schedule of Tenant Assistance Payments Due
- HUD-52670-A, Part 5, Approved Special Claims for Schedule of Tenant Assistance Payments Due

NOTE: Instructions for form HUD-52670-A, Part 2, Special Claims Schedule, and a revision to remove the MAT Field requirements in Appendix 7-A, The HUD-50059 Data Requirements, of Handbook 4350.3 REV-1, *Occupancy Requirements of Subsidized Multifamily Housing Programs*, will be posted to HUDCLIPS at a later date. A Listserv message will be sent out when these items are posted.

#182 – Multifamily Housing EIV 9.0 Release Summary - Updated – September 24, 2009

Attention: Multifamily EIV Users

The Multifamily EIV system summary below that was included in Listserv #177 has been updated to indicate that the Security Awareness Testing Module is being phased in for external users and the summary includes the phase-in schedule. Until December 1, 2009, only users with the HSC role have the ability to take the Security Awareness Training Questionnaire through the EIV system. All other external users must still use the version that may be downloaded from the Multifamily EIV website at: <http://www.hud.gov/offices/hsg/mfh/rhiip/eiv/securityawareness.pdf> until such time as the Security Awareness Testing Module is available to them in the EIV system according to the schedule below.

“Multifamily Housing EIV 9.0 Release Summary - Updated”

Function	Description
EIV — Security Awareness Testing Module	
For External Users (HSC, CAC, CAU, HSU)	<ul style="list-style-type: none"> External users need to pass this test (90% passing grade) once in a year to gain access to EIV system. Coordinators (HSC, CAC) have 15 questions to answer. External users (HSU, CAU) have 10 questions to answer. The result of a user’s security test will be available to print for a year inside EIV.
Phased-in Schedule for External Users Testing	<ul style="list-style-type: none"> The Security Awareness Questionnaire is being phased-in by user’s role for online completion as follows: <ul style="list-style-type: none"> HSC users upon entering EIV on the September 2009 Release date; CAC users on or after December 01, 2009; HSU users on or after March 01, 2009; CAU users on or after June 01, 2009.
EIV — Income Information Reports	
by Contract Number	<ul style="list-style-type: none"> Changed the module name from By Subsidy Contract to By Contract Number. Masked the tenant SSN (except last 4 digits) and DOB (except year) in all reports.
by Project Number	<ul style="list-style-type: none"> Masked the tenant SSN (except last 4 digits) and DOB (except year) in all reports.
by Head of Household	<ul style="list-style-type: none"> Masked the tenant SSN (except last 4 digits) and DOB (except year) in all reports. Removed the Confirmation – 3rd Party Verification tab.
EIV — Verification Reports	

Function	Description
Deceased Tenants Report	<ul style="list-style-type: none"> • Masked the tenant SSN (except last 4 digits) and DOB (except year) in all reports. • Added date received by EIV to indicate the date EIV received the data from SSA.
Multiple Subsidy Report	<ul style="list-style-type: none"> • Masked the tenant SSN (except last 4 digits) and DOB (except year) in all reports. • New filters for searching the multiple subsidy report: <ul style="list-style-type: none"> ○ By all household members ○ Only adult household members ○ Only members under the age of 18
EIV- User Access Requests	
Authorization Form	<ul style="list-style-type: none"> • The Security awareness test checkbox has been removed from CAAF and UAAF forms.
EIV- External Links	
Link to DHS SAVE System	<ul style="list-style-type: none"> • A link to the Department of Homeland Security SAVE (System Alien Verification for Entitlements) system is displayed at the top.
EIV- Link to Welcome Page	
Back to EIV Main Page	<ul style="list-style-type: none"> • A link back to EIV Welcome page is available from anywhere in the application.

**#181 – Multifamily Housing EIV - New Rules of Behavior for Non-System Users –
September 24, 2009**

Attention: Multifamily EIV Users

HUD's Office of Multifamily Housing has developed a *new* Rules of Behavior for Use of Enterprise Income Verification (EIV) Information (for Individuals without Access to the EIV System).

This form is to be used by private owners and/or management agents (O/As), contract administrators (CAs), and independent public auditors (IPAs) who do not have access to the EIV system, but are required to use EIV information provided to them by authorized EIV system users for the performance of official HUD business.

The form is to be completed by those individuals once and will need to be maintained onsite and available for review by HUD and CA staff. This form will be valid until a revision is issued.

The *Rules of Behavior for Use of Enterprise Income Verification (EIV) Information (for Individuals without Access to the EIV System)* can be found on the Multifamily EIV Application webpage under Related Information at: <http://www.hud.gov/offices/hsg/mfh/rhiip/eiv/rulesofbehavior.pdf>.

**#180 – New HUDCLIPS Postings for Handbook 4350.3 REV-1 and Translated Leases –
September 18, 2009**

New HUDCLIPS Postings for Handbook 4350.3 REV-1 and Translated Leases

The Department has posted the Word Version of all of the Chapters, Exhibits, and Appendices of HUD Handbook 4350.3, *Occupancy Requirements of Subsidized Multifamily Housing Programs* to HUDCLIPS. In addition, a complete version of HUD Handbook 4350.3 in one pdf file has also been posted to improve its search capability. All of this material can be found at <http://www.hud.gov/offices/adm/hudclips/handbooks/hsg/4350.3/index.cfm>.

A reformatted version of the Amharic translation of each of the Model Leases has been posted to HUDCLIPS as well at <http://www.hud.gov/offices/adm/hudclips/forms/hud9.cfm>.

NEW REQUIREMENT FOR OWNERS AND MANAGEMENT AGENTS

SUPPLEMENTAL INFORMATION TO APPLICATION

Housing Notice H 2009-13, Supplemental Information to Application for Assistance Regarding Identification of Family Member, Friend or Other Person or Organization Supportive of a Tenant for Occupancy in HUD Assisted Housing, was issued on September 15, 2009. The Notice also transmits form HUD-92006, Supplement to Application for Federally Assisted Housing.

The Notice provides guidance on implementation of the requirements of Section 644 of the Housing and Community Development Act of 1992 (Section 644). Section 644 requires that owners and management agents (O/As) must provide applicants as part of their application for housing, the option to include information on an individual or organization that the O/A may contact to assist in providing any delivery of services or special care to applicants who become tenants and to assist with resolving any tenancy issues arising during tenancy.

In order to ensure that O/As comply with this requirement, HUD has provided a standard form for use in gathering the information from applicants. Completion of the form is optional on the part of the applicant. O/As must begin including form HUD-92006 as part of their application package by no later than 90 days from the date the Notice was issued, September 15, 2009. Section 644 requires that O/As keep the contact information confidential and can only release the information for the stated statutory purpose: *To assist the O/A in providing services or special care for such tenants, and in resolving issues that may arise during the tenancy of such tenants.*

Notice H 2009-13 is posted at: <http://www.hud.gov/offices/adm/hudclips/notices/hsg/>

Form HUD-92006 is posted at: <http://www.hud.gov/offices/adm/hudclips/forms/>

#178 – Multifamily Housing EIV System Available For Use – September 15, 2009

Multifamily EIV System Available For Use

The Multifamily EIV system, which now includes the EIV 9.0 Release features described in RHIP Listserv #177, is now available for use. We apologize for any inconvenience caused by the temporary lack of availability to the system.

#177 – Multifamily Housing EIV 9.0 Release Summary – September 14, 2009

Attention: Multifamily EIV Users

The Multifamily EIV system will not be available until Wednesday, September 16, 2009, at 7:00 a.m. We apologize for any inconvenience this may cause.

When the system becomes available again, the features of the *new* EIV 9.0 Release for Multifamily Housing Programs will be ready to use. See below which summarizes changes made with this release.

“Multifamily Housing EIV 9.0 Release Summary”

Function	Description
EIV — Security Awareness Testing Module	
For External Users (HSC, CAC, CAU, HSU)	<ul style="list-style-type: none"> • External users need to pass this test (90% passing grade) once in a year to gain access to EIV system. • Coordinators (HSC, CAC) have 15 questions to answer. • External users (HSU, CAU) have 10 questions to answer. • The result of a user’s security test will be available to print for a year inside EIV.
EIV — Income Information Reports	
by Contract Number	<ul style="list-style-type: none"> • Changed the module name from By Subsidy Contract to By Contract Number. • Masked the tenant SSN (except last 4 digits) and DOB (except year) in all reports.
by Project Number	<ul style="list-style-type: none"> • Masked the tenant SSN (except last 4 digits) and DOB (except year) in all reports.
by Head of Household	<ul style="list-style-type: none"> • Masked the tenant SSN (except last 4 digits) and DOB (except year) in all reports. • Removed the Confirmation – 3rd Party Verification tab.
EIV — Verification Reports	
Deceased Tenants Report	<ul style="list-style-type: none"> • Masked the tenant SSN (except last 4 digits) and DOB (except year) in all reports. • Added date received by EIV to indicate the date EIV received the data from SSA.
Multiple Subsidy Report	<ul style="list-style-type: none"> • Masked the tenant SSN (except last 4 digits) and DOB (except year) in all reports. • New filters for searching the multiple subsidy report: <ul style="list-style-type: none"> • By all household members • Only adult household members • Only members under the age of 18

EIV- User Access Requests	
Authorization Form	<ul style="list-style-type: none">• The Security awareness test checkbox has been removed from CAAF and UAAF forms.
EIV- External Links	
Link to DHS SAVE System	<ul style="list-style-type: none">• A link to the Department of Homeland Security SAVE (System Alien Verification for Entitlements) system is displayed at the top.
EIV- Link to Welcome Page	
Back to EIV Main Page	<ul style="list-style-type: none">• A link back to EIV Welcome page is available from anywhere in the application.

Notice on State Lifetime Sex Offender Registration Issued

Notice H 2009-11 was issued on September 9, 2009, that reiterates current regulatory requirements whereby owners and management agents must perform necessary criminal history background checks to determine if an applicant, or a member of an applicant's household, is subject to a lifetime registration requirement under a State sex offender registration program. The Notice also strongly encourages that owners and management agents establish standards and processes with a zero tolerance approach to prevent lifetime sex offenders from receiving federal housing assistance. The following new processes are recommended:

- Ask households at each recertification whether any member is subject to a lifetime registration requirement under a State sex offender registration program.
- Use the Dru Sjodin National Sex Offender website to confirm that applicants and federal housing assistance recipients are not lifetime registered sex offenders.
- Aggressively pursue termination of tenancy or assistance, as appropriate, for tenants subject to a State lifetime sex offender registration requirement to the extent currently allowed by law.

The Notice is posted on:

HUDCLIPS at: <http://www.hud.gov/offices/adm/hudclips/notices/hsg/>

Multifamily Housing's RHIP website at: <http://www.hud.gov/offices/hsg/mfh/rhiip/mfhrhiip.cfm>

APPLICANT/TENANT DISCLOSURE OF SOCIAL SECURITY NUMBER (SSN)

The effective date of the Refinement of Income and Rent Determination Requirements in Public and Assisted Housing Programs, Final Rule has been delayed to January 31, 2010, as announced in the Federal Register on August 28, 2009. This final rule will revise HUD's regulations at 24 CFR 5.216 to require disclosure of SSNs by all individuals applying for or participating in HUD's rental assistance programs except for those who do not contend to have eligible immigration status.

Although the effective date of the rule has been delayed, owners and management agents are encouraged to continue informing applicants and tenants of the revisions to the SSN disclosure and verification requirements. Once the Final Rule is in effect, applicants will be required to disclose and provide verification of the SSN for all members of their household before they can be admitted. Current tenants will be required to disclose and provide verification of SSNs for all members of their household, where disclosure and verification has not occurred, at the time of their next interim or annual recertification.

Owners and management agents are encouraged to continue informing applicants and tenants who have not disclosed their SSN, or the SSN of a child under the age of 6, or who have certified they do not have a SSN, of this upcoming revision to the regulations and their need to begin the process of obtaining a SSN.

In addition to the above, owners and management agents who have access to the Enterprise Income Verification (EIV) system should continue verifying and correcting SSNs for individuals listed on the Failed EIV Pre-screening and the Failed Verification Report as having invalid SSNs.

#174 – Delayed - Refinement of Income and Rent Determination Requirements, Final Rule – August 28, 2009

Effective Date Delayed to January 31, 2010

**Refinement of Income and Rent Determination Requirements
in Public and Assisted Housing Programs, Final Rule**

A delay in the effective date of the Refinement of Income and Rent Determination Requirements in Public and Assisted Housing Programs, Final Rule was published in the Federal Register today, August 28, 2009. The rule, scheduled to be effective on September 30, 2009, **will become effective on January 31, 2010**. The publication of this delay in the effective date is located at <http://edocket.access.gpo.gov/2009/pdf/E9-20879.pdf>.

As a reminder, the provisions published in the January 27, 2009, final rule must not be implemented prior to the effective date of the final rule.

#173 – EIV Webcast Comprehensive Slides and User Guides Reposted – August 27, 2009

**EIV Webcast Comprehensive Slides and User Manuals
Reposted**

The comprehensive slides for the EIV webcast conducted December 16 & 17, 2008, and the EIV User Manuals have been reposted to HUD's Multifamily EIV website. The EIV webcast is expected to be reposted soon; a future listserv message will announce when the webcast has been posted back to the website. The Rent and Income Determination Quality Control Monitoring Guide has also been reposted to the RHIP website. We apologize for any inconvenience that the temporary removal of these documents may have caused.

NEED A REFRESHER ON TENANT INTERVIEWING SKILLS????

Do you apply the C.A.V.E. methodology when interviewing your tenants?

- **Collection** of complete information
- **Analysis** of the information to determine verification requirements and to resolve discrepancies
- **Verification** of the information
- **Education** of applicants and tenants on what is required and how the program works

Collection + **A**nalysis + **V**erification + **E**ducation = Correct eligibility determinations, tenant selection decisions and correct rent determinations

As part of the Rental Housing Integrity Improvement Project (RHIP), HUD issued “*A Guide to Interviewing for Owners of HUD-Subsidized Multifamily Projects.*” This Guide provides great techniques for interviewing applicants and tenants to ensure they understand the reasons for and importance of disclosing the information needed for determining their eligibility and rent. Accurate eligibility and rent determinations ensures that “the right benefits go to the right persons” and helps eliminate improper rental assistance payments being paid by HUD. This Guide is a great tool for owners and management agents to use in training their staff who conduct tenant interviews.

“*A Guide to Interviewing for Owners of HUD-Subsidized Multifamily Housing Projects*” is posted on the Multifamily RHIP website at:
<http://www.hud.gov/offices/hsg/mfh//rhiip/mfhrhiip.cfm>.

#171 – EIV Webcast and Users Guide Temporarily Unavailable – August 11, 2009

**EIV Webcast and User Guides
Temporarily Unavailable**

The EIV webcast conducted December 16 & 17, 2008, and the EIV User Guides have temporarily been removed from HUD's Multifamily EIV website. These resources have removed in order to review and update the content. A future listserv message will be distributed as soon as these resources have been posted back to the website.

**#180 – New HUDCLIPS Postings for Handbook 4350.3 REV-1 and Translated Leases –
September 18, 2009**

New HUDCLIPS Postings for Handbook 4350.3 REV-1 and Translated Leases

The Department has posted the Word Version of all of the Chapters, Exhibits, and Appendices of HUD Handbook 4350.3, *Occupancy Requirements of Subsidized Multifamily Housing Programs* to HUDCLIPS. In addition, a complete version of HUD Handbook 4350.3 in one pdf file has also been posted to improve its search capability. All of this material can be found at <http://www.hud.gov/offices/adm/hudclips/handbooks/hsg/4350.3/index.cfm>.

A reformatted version of the Amharic translation of each of the Model Leases has been posted to HUDCLIPS as well at <http://www.hud.gov/offices/adm/hudclips/forms/hud9.cfm>.

NEW REQUIREMENT FOR OWNERS AND MANAGEMENT AGENTS

SUPPLEMENTAL INFORMATION TO APPLICATION

Housing Notice H 2009-13, Supplemental Information to Application for Assistance Regarding Identification of Family Member, Friend or Other Person or Organization Supportive of a Tenant for Occupancy in HUD Assisted Housing, was issued on September 15, 2009. The Notice also transmits form HUD-92006, Supplement to Application for Federally Assisted Housing.

The Notice provides guidance on implementation of the requirements of Section 644 of the Housing and Community Development Act of 1992 (Section 644). Section 644 requires that owners and management agents (O/As) must provide applicants as part of their application for housing, the option to include information on an individual or organization that the O/A may contact to assist in providing any delivery of services or special care to applicants who become tenants and to assist with resolving any tenancy issues arising during tenancy.

In order to ensure that O/As comply with this requirement, HUD has provided a standard form for use in gathering the information from applicants. Completion of the form is optional on the part of the applicant. O/As must begin including form HUD-92006 as part of their application package by no later than 90 days from the date the Notice was issued, September 15, 2009. Section 644 requires that O/As keep the contact information confidential and can only release the information for the stated statutory purpose: *To assist the O/A in providing services or special care for such tenants, and in resolving issues that may arise during the tenancy of such tenants.*

Notice H 2009-13 is posted at: <http://www.hud.gov/offices/adm/hudclips/notices/hsg/>

Form HUD-92006 is posted at: <http://www.hud.gov/offices/adm/hudclips/forms/>

#178 – Multifamily Housing EIV System Available For Use – September 15, 2009

Multifamily EIV System Available For Use

The Multifamily EIV system, which now includes the EIV 9.0 Release features described in RHIP Listserv #177, is now available for use. We apologize for any inconvenience caused by the temporary lack of availability to the system.

#177 – Multifamily Housing EIV 9.0 Release Summary – September 14, 2009

Attention: Multifamily EIV Users

The Multifamily EIV system will not be available until Wednesday, September 16, 2009, at 7:00 a.m. We apologize for any inconvenience this may cause.

When the system becomes available again, the features of the *new* EIV 9.0 Release for Multifamily Housing Programs will be ready to use. See below which summarizes changes made with this release.

“Multifamily Housing EIV 9.0 Release Summary”

Function	Description
EIV — Security Awareness Testing Module	
For External Users (HSC, CAC, CAU, HSU)	<ul style="list-style-type: none"> • External users need to pass this test (90% passing grade) once in a year to gain access to EIV system. • Coordinators (HSC, CAC) have 15 questions to answer. • External users (HSU, CAU) have 10 questions to answer. • The result of a user’s security test will be available to print for a year inside EIV.
EIV — Income Information Reports	
by Contract Number	<ul style="list-style-type: none"> • Changed the module name from By Subsidy Contract to By Contract Number. • Masked the tenant SSN (except last 4 digits) and DOB (except year) in all reports.
by Project Number	<ul style="list-style-type: none"> • Masked the tenant SSN (except last 4 digits) and DOB (except year) in all reports.
by Head of Household	<ul style="list-style-type: none"> • Masked the tenant SSN (except last 4 digits) and DOB (except year) in all reports. • Removed the Confirmation – 3rd Party Verification tab.
EIV — Verification Reports	
Deceased Tenants Report	<ul style="list-style-type: none"> • Masked the tenant SSN (except last 4 digits) and DOB (except year) in all reports. • Added date received by EIV to indicate the date EIV received the data from SSA.
Multiple Subsidy Report	<ul style="list-style-type: none"> • Masked the tenant SSN (except last 4 digits) and DOB (except year) in all reports. • New filters for searching the multiple subsidy report: <ul style="list-style-type: none"> • By all household members • Only adult household members • Only members under the age of 18

EIV- User Access Requests	
Authorization Form	<ul style="list-style-type: none">• The Security awareness test checkbox has been removed from CAAF and UAAF forms.
EIV- External Links	
Link to DHS SAVE System	<ul style="list-style-type: none">• A link to the Department of Homeland Security SAVE (System Alien Verification for Entitlements) system is displayed at the top.
EIV- Link to Welcome Page	
Back to EIV Main Page	<ul style="list-style-type: none">• A link back to EIV Welcome page is available from anywhere in the application.

Notice on State Lifetime Sex Offender Registration Issued

Notice H 2009-11 was issued on September 9, 2009, that reiterates current regulatory requirements whereby owners and management agents must perform necessary criminal history background checks to determine if an applicant, or a member of an applicant's household, is subject to a lifetime registration requirement under a State sex offender registration program. The Notice also strongly encourages that owners and management agents establish standards and processes with a zero tolerance approach to prevent lifetime sex offenders from receiving federal housing assistance. The following new processes are recommended:

- Ask households at each recertification whether any member is subject to a lifetime registration requirement under a State sex offender registration program.
- Use the Dru Sjodin National Sex Offender website to confirm that applicants and federal housing assistance recipients are not lifetime registered sex offenders.
- Aggressively pursue termination of tenancy or assistance, as appropriate, for tenants subject to a State lifetime sex offender registration requirement to the extent currently allowed by law.

The Notice is posted on:

HUDCLIPS at: <http://www.hud.gov/offices/adm/hudclips/notices/hsg/>

Multifamily Housing's RHIP website at: <http://www.hud.gov/offices/hsg/mfh/rhiip/mfhrhiip.cfm>

APPLICANT/TENANT DISCLOSURE OF SOCIAL SECURITY NUMBER (SSN)

The effective date of the Refinement of Income and Rent Determination Requirements in Public and Assisted Housing Programs, Final Rule has been delayed to January 31, 2010, as announced in the Federal Register on August 28, 2009. This final rule will revise HUD's regulations at 24 CFR 5.216 to require disclosure of SSNs by all individuals applying for or participating in HUD's rental assistance programs except for those who do not contend to have eligible immigration status.

Although the effective date of the rule has been delayed, owners and management agents are encouraged to continue informing applicants and tenants of the revisions to the SSN disclosure and verification requirements. Once the Final Rule is in effect, applicants will be required to disclose and provide verification of the SSN for all members of their household before they can be admitted. Current tenants will be required to disclose and provide verification of SSNs for all members of their household, where disclosure and verification has not occurred, at the time of their next interim or annual recertification.

Owners and management agents are encouraged to continue informing applicants and tenants who have not disclosed their SSN, or the SSN of a child under the age of 6, or who have certified they do not have a SSN, of this upcoming revision to the regulations and their need to begin the process of obtaining a SSN.

In addition to the above, owners and management agents who have access to the Enterprise Income Verification (EIV) system should continue verifying and correcting SSNs for individuals listed on the Failed EIV Pre-screening and the Failed Verification Report as having invalid SSNs.

#174 – Delayed - Refinement of Income and Rent Determination Requirements, Final Rule – August 28, 2009

Effective Date Delayed to January 31, 2010

**Refinement of Income and Rent Determination Requirements
in Public and Assisted Housing Programs, Final Rule**

A delay in the effective date of the Refinement of Income and Rent Determination Requirements in Public and Assisted Housing Programs, Final Rule was published in the Federal Register today, August 28, 2009. The rule, scheduled to be effective on September 30, 2009, **will become effective on January 31, 2010**. The publication of this delay in the effective date is located at <http://edocket.access.gpo.gov/2009/pdf/E9-20879.pdf>.

As a reminder, the provisions published in the January 27, 2009, final rule must not be implemented prior to the effective date of the final rule.

#173 – EIV Webcast Comprehensive Slides and User Guides Reposted – August 27, 2009

**EIV Webcast Comprehensive Slides and User Manuals
Reposted**

The comprehensive slides for the EIV webcast conducted December 16 & 17, 2008, and the EIV User Manuals have been reposted to HUD's Multifamily EIV website. The EIV webcast is expected to be reposted soon; a future listserv message will announce when the webcast has been posted back to the website. The Rent and Income Determination Quality Control Monitoring Guide has also been reposted to the RHIP website. We apologize for any inconvenience that the temporary removal of these documents may have caused.

NEED A REFRESHER ON TENANT INTERVIEWING SKILLS????

Do you apply the C.A.V.E. methodology when interviewing your tenants?

- **Collection** of complete information
- **Analysis** of the information to determine verification requirements and to resolve discrepancies
- **Verification** of the information
- **Education** of applicants and tenants on what is required and how the program works

Collection + **A**nalysis + **V**erification + **E**ducation = Correct eligibility determinations, tenant selection decisions and correct rent determinations

As part of the Rental Housing Integrity Improvement Project (RHIP), HUD issued “*A Guide to Interviewing for Owners of HUD-Subsidized Multifamily Projects.*” This Guide provides great techniques for interviewing applicants and tenants to ensure they understand the reasons for and importance of disclosing the information needed for determining their eligibility and rent. Accurate eligibility and rent determinations ensures that “the right benefits go to the right persons” and helps eliminate improper rental assistance payments being paid by HUD. This Guide is a great tool for owners and management agents to use in training their staff who conduct tenant interviews.

“*A Guide to Interviewing for Owners of HUD-Subsidized Multifamily Housing Projects*” is posted on the Multifamily RHIP website at:
<http://www.hud.gov/offices/hsg/mfh//rhiip/mfhrhiip.cfm>.

#171 – EIV Webcast and Users Guide Temporarily Unavailable – August 11, 2009

**EIV Webcast and User Guides
Temporarily Unavailable**

The EIV webcast conducted December 16 & 17, 2008, and the EIV User Guides have temporarily been removed from HUD's Multifamily EIV website. These resources have removed in order to review and update the content. A future listserv message will be distributed as soon as these resources have been posted back to the website.

#170 – EIV & You Brochure, Correction to Handbook 4350.3 REV-1 Exhibits, & One-Time Economic Recovery Payment Guidance – August 4, 2009

Attention Enterprise Income Verification (EIV) System Multifamily Housing Program Users

**EIV & You Brochure
Now Available!**

Good News! The links below will direct you to the new **EIV & You** brochure. This brochure explains to tenants what information is available in EIV and how this information may be used. Another Listserv message will be posted once a printed version of the brochure is available. Owners and management agents may currently access and print the brochure by following the links below. A Notice will be forthcoming that will provide owners and management agents the requirements for distributing the brochure to tenants.

RHIIP: <http://www.hud.gov/offices/hsg/mfh/rhiip/mfhrhiip.cfm> under Other Publications

EIV: <http://www.hud.gov/offices/hsg/mfh/rhiip/eiv/eivhome.cfm> under What's Hot!

**HANDBOOK 4350.3 REV-1
EXHIBIT CORRECTIONS**

When Handbook 4350.3 REV-1, *Occupancy Requirements of Subsidized Multifamily Programs*, Change 3 was posted, the links included in the listing of Exhibits at the end of Chapters 3, 4, 5 and 7 did not work. The links have now been corrected and the chapters have been re-posted on HUDCLIPS. If you printed the Chapters, you should print and replace pages 3-79, 3-80, 4-61, 5-80 and 7-32.

Also, the Exhibits themselves were removed from the end of the chapters and posted separately on HUDCLIPS. In doing this, the web link for Exhibit 4-2 was for the Department of Homeland Security's form G-845 rather than G-845S. The link for Exhibit 4-2 has been corrected in HUDCLIPS. The correct link is: <http://www.uscis.gov/files/form/g-845s.pdf>

Guidance on Social Security's One-Time Economic Recovery Payment

Notice H 09-07, *Fiscal Year 2009 Social Security's One-Time Economic Recovery Payments Excluded from Income* was issued July 27, 2009. This notice provides for the exclusion of the Social Security's One-Time Economic Recovery Payments received by applicants for assisted housing and by tenants participating in HUD's rental assistance programs. The notice is posted on HUDCLIPS at: <http://www.hud.gov/offices/adm/hudclips/notices/hsg/>.

EIV Q&A'S FROM DECEMBER TRAINING REVISED

The Q&As from the Multifamily EIV training on December 16 and 17, 2008 have been revised and re-posted to the Multifamily EIV website at:

<http://www.hud.gov/offices/hsg/mfh/rhiip/eiv/eivhome.cfm>. The only revision made was to combine Questions 35 and 36. These questions were combined to provide clarity on when the EIV Income Report can be used as third party verification and when it can or cannot be used for calculating annual income.

Attention!

4350.3 Change 3 Mailbox Change

Please use 4350.3chg.3comments@hud.gov

RHIIP Listserv message #167 indicated a mailbox had been established where questions and/or comments relating to Change 3 of HUD Handbook 4350.3 REV-1, *Occupancy Requirements of Subsidized Multifamily Housing Programs*, could be sent. Although the address appeared correct, we were informed that messages were not being delivered. To correct this, we have removed the spaces which should solve the problem. Please send all comments to the new email address 4350.3chg.3comments@hud.gov. Thank you for your patience and we apologize for any inconvenience.

#167 – Mailbox Established for Handbook 4350.3 REV-1 Questions/Comments and Attachment 22 to the Section 8 Renewal Guide Replaced – July 22, 2009

**DO YOU HAVE QUESTIONS OR COMMENTS ON
CHANGE 3 TO HANDBOOK 4350.3 REV-1???**

On June 23, 2009, Change 3 to Handbook 4350.3 REV-1, *Occupancy Requirements of Subsidized Multifamily Housing Programs*, was issued. The effective date for implementation of Change 3 is August 1, 2009. The handbook is posted on HUDCLIPS at:
<http://www.hud.gov/offices/adm/hudclips/handbooks/hsg/4350.3/index.cfm>.

A mailbox has been established whereby you can send your questions and/or comments relating to Change 3 to the Handbook. Please limit your questions and/or comments to Change 3 revisions only (see the Transmittal for Change 3 posted with the Handbook on HUDCLIPS for a summary of the Change 3 revisions). The questions and/or comments will be compiled into a Questions and Answers (Q&S) document. Once answers have been prepared for all of the questions and/or comments, the Q&A document will be released. The address for the mailbox is 4350.3_Chg.3_comments@hud.gov.

**Attachment 22 Consent To Assignment of HAP Contract as
Security for FNMA Financing Replaced**

Attachment 22 to the Section 8 Renewal Guide has been corrected. On April 13, 2009, the Department issued several page changes to the Section 8 Renewal Guide which included four attachments where HUD can consent to the assignment of the HAP Contract by the owner to the lender as security for a loan.

Attachment 22 "*Consent To Assignment of HAP Contract as Security for FNMA Financing*" was inadvertently posted using the text for a different attachment. The Department has corrected this error and reposted the correct version on the Section 8 Contracts website
<http://www.hud.gov/offices/hsg/mfh/mfhsec8.cfm>.

Please insure that the correct version of Attachment 22 is used.

URGENT SAVE UPDATE!!

Good news! The Department of Homeland Security has provided HUD with additional time for HUD-assisted properties to get signed up for its SYSTEMATIC ALIEN VERIFICATION FOR ENTITLEMENTS (SAVE) system.

If you are the owner or management agent of a HUD-assisted property and have **not** yet sent in the contact information for one designated person per property to get access to the SAVE system, please do so now and take advantage of this one-time opportunity. The person designated should be the one who will need to use the SAVE system to verify the citizenship status of applicants or tenants who are noncitizens and who claim eligible immigration status.

If you have submitted your information already, DO NOT RESUBMIT and DO NOT CALL HUD to see if your information was received or DHS regarding IDs and passwords.

NOTE: If you are the owner or management agent of a Section 202 property with units not receiving rental assistance under the Rent Supplement or Section 8 programs, a Section 202 PRAC property, a Section 202 PAC property, a Section 811 PRAC property or a Section 221(d)(3) BMIR property, **DO NOT RESPOND** since your property is not subject to the noncitizen rule and would, therefore, not need to use the SAVE system.

Directions

- 1) Fill in each column on the attached excel spreadsheet for the person designated to have access to the SAVE system. The excel spreadsheet can also be downloaded from the following website:
<http://www.hud.gov/offices/hsg/mfh/rhiip/mfhrhiip.cfm>
- 2) Send it by email to SAVEaccess@hud.gov no later than **July 24, 2009**.

After the uploading is completed (later this summer), each person that has been uploaded into the SAVE system will receive an email with their User ID and temporary password to access the SAVE system.

Questions and Answers

Why should I designate someone to get access to the SAVE System?

To ensure that HUD's rental assistance is provided only to eligible noncitizens, owners and management agents of properties (other than the ones listed in the NOTE above) **must** use the SAVE system to verify the validity of citizenship documents provided by applicants or tenants who are noncitizens and who claim eligible immigration status.

I don't have any noncitizen tenants and never get any noncitizen applicants. Why should my property get access to the SAVE system?

There is always a chance that a noncitizen will apply to live in your property. Since the SAVE system must be used by properties (other than those listed in the NOTE above) to verify the validity of citizenship documents should this occur, it is best to be prepared and get access now.

Already have access to SAVE?

Due to the fact that DHS is streamlining the SAVE database, if your property already has access to the SAVE system, you still need to designate one person to have access and complete the

information requested above by the established deadline so that this person will receive a new User ID and temporary password. We apologize for any inconvenience this may cause you. **There will be no suspension of existing SAVE accounts during this process. If you currently have access, continue as you have been. When the new ID is ready for the person designated for the one-time upload, it will be emailed to you promptly.**

Need more than one person to have access to SAVE?

If your property has access to SAVE now and more than one person has access, or if your property does not have access to SAVE currently and you need more than one person to have access, additional people can be provided access through a manual process that will take place at HUD. Further instructions about the manual process will be provided once the one-time upload process is completed.

If you have any questions regarding this request you may contact Kevin Garner at (202) 402-2057 or (202) 708-3000.

Excel Attachment LS166

**HURRY – GET ACCESS TO EIV NOW AND AVOID THE CRUNCH!
EIV TO BECOME MANDATORY ON SEPTEMBER 30, 2009**

The use of the Enterprise Income Verification (EIV) system for Multifamily will become mandatory on **September 30, 2009**, as required by the "Refinement of Income and Rent Determination Requirements in Public and Assisted Housing Programs" Final Rule published in the Federal Register on March 27, 2009 (74 FR 13339). This Notice, along with other EIV-related source documents, can be found on the **Multifamily Housing Program Requirements and Guidance for Using EIV** web page, located at: <http://www.hud.gov/offices/hsg/mfh/rhiip/eiv/reqnguide.cfm>

In order to avoid the potential delay in getting access that could result from waiting until close to the September 30, 2009 effective date, those **owners and management agents (O/As) who do not currently have access to the EIV system should obtain access now** and become familiar with using the system. Contract Administrators (CAs) are also encouraged to gain access to and use the system in the performance of Management and Occupancy Reviews (MORs), the purpose of which is to identify and reduce errors in the administration of HUD rental assistance programs, thereby reducing the number and amount of improper payments of HUD subsidies. Information on applying for access to the EIV system for Multifamily users is available at: <http://www.hud.gov/offices/hsg/mfh/rhiip/eiv/eivhome.cfm>.

Thank you for your interest in HUD's EIV System and for assisting the Department to further reduce income and rent determination errors through continued and regular use of the system.

HANDBOOK 4350.3 REV-1 CHG-3 ISSUED

Change 3 to Handbook 4350.3 REV-1, *Occupancy Requirements of Subsidized Multifamily Housing Programs*, was issued on June 23, 2009. The effective date for implementation of Change 3 is August 1, 2009.

The majority of the changes are corrections or clarifications to current handbook text. Some of the more significant changes are:

- Updates information on access to and use of the Systematic Alien Verification Entitlements (SAVE) system used for verifying the immigration status of individuals declaring eligible non-citizen status.
- Revises and expands the requirements for a live-in aide.
- Incorporates the requirements from Housing Notice H 03-07 on treatment of deployment of military personnel to active duty.
- Clarifies that the same requirements for treatment of Federal Government pension funds paid directly to an applicant's/tenant's former spouse pursuant to the terms of a court decree of divorce, annulment, or legal separation also applies to Uniformed Services pensions and other state, local government, social security or private pension funds.
- Includes that owners may develop rules covering tenants conducting incidental business in their units and who receive incidental business income.
- Removes the requirement that signatures on the HUD-50059-A for gross rent increases must be obtained before submitting the data to TRACS. A note has been added that tenant signatures for gross rent changes affecting the rent the household must pay or utility reimbursement must be obtained within 60 days from the date the gross rent change is implemented by the owner, as evidenced by the owner's submission of the voucher whereby the owner begins vouchering for assistance based on the new rents.
- Clarifies that when HUD or the Contract Administrator terminates assistance payments when a new certification is not submitted to TRACS within 15 months of the previous year's recertification anniversary date, the owner must repay the assistance collected for the 3-month period from the date the annual recertification should have been effective through the end of the 15th month when assistance was terminated.
- Includes TRACS 202C requirements which includes implementation of the new HUD-50059-A, *Owner's Certification of Compliance with HUD's Tenant Eligibility and Rent Procedures – Partial Certification*.

Handbook 4350.3 REV-1, CHG-3 is posted on HUDCLIPS at:
<http://www.hud.gov/offices/adm/hudclips/handbooks/hsg/4350.3/index.cfm>.

If you have any questions regarding Change 3, please contact your local Contract Administrator or HUD Field Office.

#163 – Update to #158 Regarding Exclusion of Deferred Department of Veterans Affairs Disability Benefits from Annual Income – June 26, 2009

Update to RHIP Listserv Message #158

Notice Published on the Exclusion of Department of Veterans Affairs Disability Benefits from Annual Income

On June 18, 2009, an updated version of Housing Notice 09-03 *Exclusion of Deferred Department of Veterans Affairs Disability Benefits from Annual Income* was posted on HUDCLIPS. The updated notice amends Section III. Applicability of the notice to maintain consistency with the targeted programs stated in the Housing and Economic Recovery Act of 2008 (HERA) and Section I. Purpose of the notice. As previously stated in RHIP Listserv Message #158, the notice informs administrators of **project-based Section 8 programs** of the passage of HERA. As a result of HERA, any deferred Department of Veterans Affairs disability benefits that are received in a lump sum or in prospective monthly amounts by the tenant shall be excluded as annual income. Housing Notice 09-03 can be found at <http://www.hud.gov/offices/adm/hudclips/notices/hsg/>.

**Attention Enterprise Income Verification (EIV) System Multifamily Housing Program Users
News Update: EIV 8.1.1 Instructional Course Webcast December 16-17, 2008
Qs & As are now available!**

Good News! The questions posed during and after the December 16-17, 2008 webcast have been answered. The Department encourages course participants as well as owners, management agents, service bureaus and contract administrators who were unable to view the webcast to download and review all of the information presented in this *question and answer summary*. Many common questions regarding the EIV system were posed, and the Department hopes that the given answers will be helpful to users of the EIV system. ***You will find the link below:***

<http://www.hud.gov/offices/hsg/mfh/rhiip/eiv/eivtraining.cfm>
These Qs & As should prove to be very helpful as the Department moves toward eventually mandating the use of EIV for multifamily housing programs.

Translations of HUD Model Leases and Sample Documents

As part of its effort to improve access to services by persons with limited English proficiency (LEP), HUD has had the HUD model leases translated into several languages. The leases translated are:

- Model Lease for Subsidized Programs (HUD-90105-A)
- Model Lease for Section 202/8 or Section 202 PAC (HUD-90105-B)
- Model Lease for Section 202 PRAC (HUD-90105-C)
- Model Lease for Section 811 PRAC (HUD-90105-D)

The leases, as well as the documents listed below, have been translated into the following languages: Arabic, Armenian, Chinese (Traditional), Farsi, French (Canadian), Khmer (Cambodian), Korean, Portuguese (Brazil), Russian, Spanish, Tagalog, and Vietnamese.

Users can access these translated leases by going to the RHIP website <http://www.hud.gov/offices/hsg/mfh/rhiip/mfhrhiip.cfm> and clicking on the link “HUD Model Lease forms (HUD-90105-a through 90105-d including translated formats)” or by going to HUDCLIPS at <http://www.hud.gov/offices/adm/hudclips/forms/hud9.cfm>. Currently the lease translations are contained in a zip file from which the user can choose the appropriate translation. The link will soon be converted to a dropdown so that users who do not have the ability to use the zip directory can more easily access the lease documents.

The Department also had the following documents translated and is in the process of posting them. The link to these documents will be provided when the posting is completed.

1. Document Package for Applicant's/Tenant's Consent to the Release of Information (HUD 9887/A, Form HUD 9887, and Relevant Verifications)
2. ****Sample**** Annual Recertification Initial Notice (HUD Handbook 4350.3, Exhibit 7-1)
3. ****Sample**** Annual Recertification First Reminder Notice (HUD Handbook 4350.3, Exhibit 7-2)
4. ****Sample**** Annual Recertification Second Reminder Notice (HUD Handbook 4350.3, Exhibit 7-3)
5. ****Sample**** Annual Recertification Third Reminder Notice / Notice of Termination (HUD Handbook 4350.3, Exhibit 7-4)
6. ****Sample**** Model Form of Notification of Rent Increase Resulting from Recertification Processing (HUD Handbook 4350.3, Exhibit 7-6)
7. ****Sample**** Interim Adjustment Initial Notice (HUD Handbook 4350.3, Exhibit 7-7)
8. ****Sample**** Interim Adjustment Termination of Assistance (HUD Handbook 4350.3, Exhibit 7-8)

EIV NEWS ALERTS!

GOOD NEWS FOR EIV USERS

DATA RETENTION REQUIREMENTS WILL CHANGE

HUD is in the process of finalizing negotiations with the Department of Health and Human Services (HHS) for retention of the National Directory of New Hires (NDNH) employment and income data obtained from the EIV system. HHS has agreed to allow retention of the EIV printed reports for the term of tenancy plus three years after termination of tenancy. With this change, owners and management agents (O/As) will no longer need to worry about destroying the EIV printed reports containing NDNH data in the tenant files when the reports are two years old. This change will be incorporated in a revision to Notice H2008-3, Enterprise Income Verification (EIV) System.

USE OF EIV TO BECOME MANDATORY

Multifamily Housing Programs Administrators

The "Refinement of Income and Rent Determination Requirements in Public and Assisted Housing Programs" Final Rule that was published in the Federal Register on March 27, 2009 (74 FR 13339) makes the use of EIV for Multifamily mandatory, effective **September 30, 2009**. This Notice, along with other EIV-related source documents, can be found on the **Multifamily Housing Program Requirements and Guidance for Using EIV** web page, located at: <http://www.hud.gov/offices/hsg/mfh/rhiip/eiv/reqnguide.cfm>

Those owners and management agents (O/As) who do not currently have access to the EIV system should obtain access as soon as possible and become familiar with using the system. Contract Administrators (CAs) are also encouraged to gain access to and use the system in the performance of Management and Occupancy Reviews (MORs), the purpose of which is to identify and reduce errors in the administration of HUD rental assistance programs, thereby reducing the number and amount of improper payments of HUD subsidies. Information on applying for access to the EIV system for Multifamily users is available at: <http://www.hud.gov/offices/hsg/mfh/rhiip/eiv/eivhome.cfm>.

Thank you for your interest in HUD's EIV System and for assisting the Department to further reduce income and rent determination errors through continued and regular use of the system.

HUD HANDBOOK 4350.1 UPDATED

Chapter 6, Project Monitoring, of HUD Handbook 4350.1, *Multifamily Asset Management and Project Servicing*, has recently been revised and is now posted on HUDClips at:

<http://www.hud.gov/offices/adm/hudclips/handbooks/hsg/4350.1/index.cfm> .

Questions on Chapter 6 should be sent to the following mailbox:
PPSDCommunications@hud.gov

#159 – Correction to Posting #158 RE: Three Items of Interest (Housing Notice 09-02 & 03 and Federal Register Notice) – June 1, 2009

CORRECTION TO RHIIP LISTSERV #158

Two notices, the Exclusion of Deferred Department of Veterans Affairs Disability Benefits from Annual Income notice and the Green Retrofit Program for Multifamily Housing (GRP) notice, were recently published with the same reference number of Housing Notice 09-02. To correct this, the Exclusion of Deferred Department of Veterans Affairs Disability Benefits from Annual Income notice has been renumbered to Housing Notice 09-03. The message below has been updated to reflect this change.

Notice Published on the Exclusion of Department of Veterans Affairs Disability Benefits from Annual Income

On May 28, 2009, Housing Notice 09-03 *Exclusion of Deferred Department of Veterans Affairs Disability Benefits from Annual Income* was posted on HUDCLIPS. This notice informs administrators of project-based Section 8 programs of the passage of the Housing and Economic Recovery Act of 2008 (HERA). As a result of HERA, any deferred Department of Veterans Affairs disability benefits that are received in a lump sum or in prospective monthly amounts by the tenant shall be excluded as annual income. Housing Notice 09-03 can be found at <http://www.hud.gov/offices/adm/hudclips/notices/hsg/>.

Federal Register Notice Published on Supplement to Application for Federally Assisted Housing

On May 19, 2009, a notice was published in the Federal Register informing the public that HUD has submitted to OMB a request for approval of the data collecting form corresponding with Section 644 of the Housing and Community Development Act of 1992. Under this Act, HUD has the obligation to require housing providers participating in HUD's assisted housing programs to provide any individual or family applying for occupancy in HUD assisted housing with the option to include in the application for occupancy the name, address, telephone number, and other relevant information of a family member, friend, or person associated with a social, health, advocacy, or similar organization.

The notice is soliciting comments from members of the public and affecting agencies concerning the proposed collection of information to:

1. Evaluate whether the proposed collection of information is necessary for the proper performance of the functions of the agency, including whether the information will have practical utility;
2. Evaluate the accuracy of the agency's estimate of the burden of the proposed collection of information;
3. Enhance the quality, utility, and clarity of the information to be collected; and
4. Minimize the burden of the collection of information on those who are to respond; including through the use of appropriate automated collection techniques or other forms of information technology, e.g., permitting electronic submission of responses.

The Federal Register publication can be found at <http://edocket.access.gpo.gov/2009/pdf/E9-11553.pdf>.

Notice of Availability: Program Requirements for the Green Retrofit Program for Multifamily Housing Under the American Recovery and Reinvestment Act of 2009

On May 18, 2009, a notice was published in the Federal Register announcing the availability of program requirements, including eligibility requirements and application instructions, for the Green Retrofit Program authorized under Title XII of the American Recovery and Reinvestment Act of 2009. The Green Retrofit Program makes funding available to multifamily owners for adopting measures that will meet requirements for green project operation. The notice establishing the program requirements is available on the HUD Web site at:

<http://www.hud.gov/recovery/> and the Federal Register publication can be found at <http://edocket.access.gpo.gov/2009/pdf/E9-11556.pdf>.

**#158 – Three Items of Interest (Housing Notice 09-02 and Federal Register Notices) –
May 29, 2009**

**Notice Published on the Exclusion of Department of Veterans Affairs Disability Benefits
from Annual Income**

On May 28, 2009, Housing Notice 09-02 *Exclusion of Deferred Department of Veterans Affairs Disability Benefits from Annual Income* was posted on HUDCLIPS. This notice informs administrators of project-based Section 8 programs of the passage of the Housing and Economic Recovery Act of 2008 (HERA). As a result of HERA, any deferred Department of Veterans Affairs disability benefits that are received in a lump sum or in prospective monthly amounts by the tenant shall be excluded as annual income. Housing Notice 09-02 can be found at <http://www.hud.gov/offices/adm/hudclips/notices/hsg/>.

**Federal Register Notice Published on Supplement to Application for Federally Assisted
Housing**

On May 19, 2009, a notice was published in the Federal Register informing the public that HUD has submitted to OMB a request for approval of the data collecting form corresponding with Section 644 of the Housing and Community Development Act of 1992. Under this Act, HUD has the obligation to require housing providers participating in HUD's assisted housing programs to provide any individual or family applying for occupancy in HUD assisted housing with the option to include in the application for occupancy the name, address, telephone number, and other relevant information of a family member, friend, or person associated with a social, health, advocacy, or similar organization.

The notice is soliciting comments from members of the public and affecting agencies concerning the proposed collection of information to:

Evaluate whether the proposed collection of information is necessary for the proper performance of the functions of the agency, including whether the information will have practical utility;

1. Evaluate the accuracy of the agency's estimate of the burden of the proposed collection of information;
2. Enhance the quality, utility, and clarity of the information to be collected; and
3. Minimize the burden of the collection of information on those who are to respond; including through the use of appropriate automated collection techniques or other forms of information technology, e.g., permitting electronic submission of responses.

The Federal Register publication can be found at <http://edocket.access.gpo.gov/2009/pdf/E9-11553.pdf>.

**Notice of Availability: Program Requirements for the Green Retrofit Program for
Multifamily Housing Under the American Recovery and Reinvestment Act of 2009**

On May 18, 2009, a notice was published in the Federal Register announcing the availability of program requirements, including eligibility requirements and application instructions, for the Green Retrofit Program authorized under Title XII of the American Recovery and Reinvestment Act of 2009. The Green Retrofit Program makes funding available to multifamily owners for adopting measures that will meet requirements for green project operation. The notice establishing the program requirements is available on the HUD Web site at:

<http://www.hud.gov/recovery/> and the Federal Register publication can be found at <http://edocket.access.gpo.gov/2009/pdf/E9-11556.pdf>.

#157 – Community Innovations for Aging in Place Initiative (CIAIP) Grants Available from HHS – May 21, 2009

Community Innovations for Aging in Place (CIAIP) Grants Available from HHS

Attached you will find authorizing legislation for the Community Innovations for Aging in Place Initiative (Initiative) and a current funding announcement for the Initiative from the Administration on Aging at the Department of Health and Human Services (HHS) that may be of interest to our Owners, Agents and other Partners. The HHS press release for the Initiative is below, with links to the funding notice. For more information, please contact Deborahburns.Kuhn@aoa.hhs.gov

May 19, 2009. Acting Assistant Secretary for Aging Edwin L. Walker is pleased to announce the availability of \$5 million for Community Innovations for Aging in Place (CIAIP) grants. These new projects will promote aging in place for older individuals by developing and implementing innovative, cost effective, comprehensive and coordinated health and social services including evidence-based disease prevention and health promotion services that allow them to continue to live in their communities among their families and friends.

“When asked, 90 percent of older adults indicate they would prefer to stay in their current residences as they age,” said Acting Assistant Secretary Walker. “These grants will help ensure that older individuals are provided the types of supports and services that will allow them to remain in their homes and communities as long as possible.”

The Community Innovations for Aging in Place program, included in the Older Americans Act Amendments of 2006, is modelled after Naturally Occurring Retirement Communities (NORCS). NORCS are neighborhoods where seniors can age in place with access to necessary support resources including transportation, health programs and social services. The CIAIP projects will build on the success of NORCS while integrating additional innovative models of aging in place.

Eligible applicants for \$4.5 million in CIAIP grants include nonprofit health or social service organizations, faith-based neighborhood organizations, community-based nonprofit organizations, area agencies on aging, local government agencies, or tribal organizations. Up to \$4.5 million will be available to fund up to 15 new Community Innovations for Aging In Place (CIAIP) grants. These grants will be funded at a federal share of approximately \$250,000 to \$500,000 per year for a project period of three years, contingent on the availability of federal funds. Applicants must be able to demonstrate a record of and experience in providing or administering group and individual health and social services for older individuals.

The Administration on Aging (AoA) will also award one grant of up to \$500,000 for a technical assistance cooperative agreement that will support the CIAIP grantees.

Eligible applicants for the cooperative agreement include non-profit organizations or partnerships of non-profit organizations. Applicants must be able to demonstrate experience and expertise in providing technical assistance on a national basis to a range of entities serving older individuals, as well as experience and expertise in aging in place models of supportive services.

The closing date for CIAIP and cooperative agreement applications under this announcement is Wednesday, July 15, 2009. For more information about the CIAIP program, please contact: Deborahburns.Kuhn@aoa.hhs.gov This e-mail address is being protected from spambots. You need JavaScript enabled to view it. To learn more about this opportunity and to view the Grant Application Instructions, please visit <http://www.aoa.gov/AoARoot/Grants/Funding/index.aspx>.

Source: [aoa.gov](http://www.aoa.gov)

COMMUNITY INNOVATIONS FOR AGING IN PLACE

Older Americans Act, Sec. 422.

(a) DEFINITIONS.—In this section:

(1) ELIGIBLE ENTITY.—The term “eligible entity” —

(A) means a nonprofit health or social service organization, a community-based nonprofit organization, an area agency on aging or other local government agency, a tribal organization, or another entity that—

(i) the Assistant Secretary determines to be appropriate to carry out a project under this part; and

(ii) demonstrates a record of, and experience in, providing or administering group and individual health and social services for older individuals; and

(B) does not include an entity providing housing under the congregate housing services program carried out under section 802 of the Cranston-Gonzalez National Affordable Housing Act (42 U.S.C. 8011) or the multifamily service coordinator program carried out under section 202(g) of the Housing Act of 1959 (12 U.S.C. 1701q(g)).

(2) NATURALLY OCCURRING RETIREMENT COMMUNITY.—The term “Naturally Occurring Retirement Community” means a community with a concentrated population of older individuals, which may include a residential building, a housing complex, an area (including a rural area) of single family residences, or a neighborhood composed of age-integrated housing—

(A) where—

(i) 40 percent of the heads of households are older individuals; or

(ii) a critical mass of older individuals exists, based on local factors that, taken in total, allow an organization to achieve efficiencies in the provision of health and social services to older individuals living in the community; and

(B) that is not an institutional care or assisted living setting.

(b) GRANTS.—

(1) IN GENERAL.—The Assistant Secretary shall make grants, on a competitive basis, to eligible entities to develop and carry out model aging in place projects. The projects shall promote aging in place for older individuals (including such individuals who reside in Naturally Occurring Retirement Communities), in order to sustain the independence of older individuals. A recipient of a grant under this subsection shall identify innovative strategies for providing, and linking older individuals to programs and services that provide, comprehensive and coordinated health and social services to sustain the quality of life of older individuals and support aging in place.

(2) GRANT PERIODS.—The Assistant Secretary shall make the grants for periods of 3 years.

(c) APPLICATIONS.—

(1) IN GENERAL.—To be eligible to receive a grant under subsection (b) for a project, an entity shall submit an application to the Assistant Secretary at such time, in such manner, and containing such information as the Assistant Secretary may require.

(2) CONTENTS.—The application shall include—

(A) a detailed description of the entity’s experience in providing services to older individuals in age-integrated settings;

- (B) a definition of the contiguous service area and a description of the project area in which the older individuals reside or carry out activities to sustain their wellbeing;
- (C) the results of a needs assessment that identifies—
 - (i) existing (as of the date of the assessment) community- based health and social services available to individuals residing in the project area;
 - (ii) the strengths and gaps of such existing services in the project area;
 - (iii) the needs of older individuals who reside in the project area; and
 - (iv) services not being delivered that would promote aging in place and contribute to the well-being of older individuals residing in the project area;
- (D) a plan for the development and implementation of an innovative model for service coordination and delivery within the project area;
- (E) a description of how the plan described in subparagraph (D) will enhance existing services described in subparagraph (C)(i) and support the goal of this section to promote aging in place;
- (F) a description of proposed actions by the entity to prevent the duplication of services funded under a provision of this Act, other than this section, and a description of how the entity will cooperate, and coordinate planning and services (including any formal agreements), with agencies and organizations that provide publicly supported services for older individuals in the project area, including the State agency and area agencies on aging with planning and service areas in the project area;
- (G) an assurance that the entity will seek to establish cooperative relationships with interested local entities, including private agencies and businesses that provide health and social services, housing entities, community development organizations, philanthropic organizations, foundations, and other non-Federal entities;
- (H) a description of the entity’s protocol for referral of residents who may require long-term care services, including coordination with local agencies, including area agencies on aging and Aging and Disability Resource Centers that serve as single points of entry to public services;
- (I) a description of how the entity will offer opportunities for older individuals to be involved in the governance, oversight, and operation of the project;
- (J) an assurance that the entity will submit to the Assistant Secretary such evaluations and reports as the Assistant Secretary may require; and
- (K) a plan for long-term sustainability of the project.

(d) USE OF FUNDS.—

- (1) IN GENERAL.—An eligible entity that receives a grant under subsection (b) shall use the funds made available through the grant to—
- (A) ensure access by older individuals in the project area to community-based health and social services consisting of—
 - (i) case management, case assistance, and social work services;
 - (ii) health care management and health care assistance, including disease prevention and health promotion services;
 - (iii) education, socialization, and recreational activities; and
 - (iv) volunteer opportunities for project participants;
 - (B) conduct outreach to older individuals within the project area; and

(C) develop and implement innovative, comprehensive, and cost-effective approaches for the delivery and coordination of community-based health and social services, including those identified in subparagraph (A)(iv), which may include mental health services, for eligible older individuals.

(2) COORDINATION.—An eligible entity receiving a grant under subsection (b) for a project shall coordinate activities with organizations providing services funded under title III to support such services for or facilitate the delivery of such services to eligible older individuals served by the project.

(3) PREFERENCE.—In carrying out an aging in place project, an eligible entity shall, to the extent practicable, serve a community of low-income individuals and operate or locate the project and services in or in close proximity to a location where a large concentration of older individuals has aged in place and resided, such as a Naturally Occurring Retirement Community.

(4) SUPPLEMENT NOT SUPPLANT.—Funds made available to an eligible entity under subsection (b) shall be used to supplement, not supplant, any Federal, State, or other funds otherwise available to the entity to provide health and social services to eligible older individuals.

(e) COMPETITIVE GRANTS FOR TECHNICAL ASSISTANCE.—

(1) GRANTS.—The Assistant Secretary shall (or shall make a grant, on a competitive basis, to an eligible nonprofit organization, to enable the organization to)—

(A) provide technical assistance to recipients of grants under subsection (b); and

(B) carry out other duties, as determined by the Assistant Secretary.

(2) ELIGIBLE ORGANIZATION.—To be eligible to receive a grant under this subsection, an organization shall be a nonprofit organization (including a partnership of nonprofit organizations), that—

(A) has experience and expertise in providing technical assistance to a range of entities serving older individuals and experience evaluating and reporting on programs; and

(B) has demonstrated knowledge of and expertise in community-based health and social services.

(3) APPLICATION.—To be eligible to receive a grant under this subsection, an organization (including a partnership of nonprofit organizations) shall submit an application to the Assistant Secretary at such time, in such manner, and containing such information as the Assistant Secretary may require, including an assurance that the organization will submit to the Assistant Secretary such evaluations and reports as the Assistant Secretary may require.

(f) REPORT.—The Assistant Secretary shall annually prepare and submit a report to Congress that shall include—

(1) the findings resulting from the evaluations of the model projects conducted under this section;

(2) a description of recommended best practices regarding carrying out health and social service projects for older individuals aging in place; and

(3) recommendations for legislative or administrative action, as the Assistant Secretary determines appropriate.

(42 U.S.C. 3032k)

CLARIFICATION TO RHIIP LISTSERV #154

**REMINDER OF UPCOMING CHANGE TO REQUIREMENT FOR
RESIDENT DISCLOSURE OF SOCIAL SECURITY NUMBERS**

There have been several requests for clarification on how the requirement for disclosure of social security numbers will affect mixed families. The requirement for the disclosure of a social security number **does not apply** to individuals in mixed families who do not contend eligible immigration status under HUD's noncitizens regulations. This was clarified in the Notice of Proposed Delay of Effective Date of the Refinement of Income and Rent Determination Requirements in Public and Assisted Housing Programs Final Rule published in the Federal Register on February 11, 2009. It was also clarified that proration of assistance and screening for these families should continue according to existing requirements. In addition, the eviction or denial of admission to individuals in mixed families cannot be authorized on the basis of the new requirement for the disclosure of a social security number.

On January 27, 2009, a Final Rule was published in the Federal Register, the effective date of which was subsequently delayed to September 30, 2009, made a revision to HUD's regulations at 24 C.F.R. 5.216 covering the requirements for disclosure of social security numbers. The revision to the regulation requires disclosure of social security numbers by **all** individuals applying for or participating in HUD's rental assistance programs who declare themselves to be a U.S. citizen, U.S. national or eligible noncitizen. Once the Final Rule is in effect, applicants will be required to disclose and provide verification of the social security number for all members of their household who declare themselves to be a U.S. citizen, U.S. national or eligible noncitizen before they can be admitted. Current residents will be required to disclose and provide verification of social security numbers for all members of their household who declare themselves to be a U.S. citizen, U.S. national or eligible noncitizen, where disclosure and verification has not occurred, at the time of their next interim or annual recertification.

Owners and management agents are encouraged to begin and continue informing applicants and residents who have not disclosed their social security number, or the social security number of a child under the age of 6, or who have certified they do not have a social security number, of this upcoming revision to the regulations as described above and their need to begin the process of obtaining a social security number.

In addition to the above, owners and management agents who have access to the Enterprise Income Verification (EIV) system should be verifying and correcting social security numbers for individuals listed on the Failed EIV Pre-screening and the Failed Verification Report as having invalid social security numbers.

#155 – URGENT - Deadline for Information Request for the Systematic Alien Verification for Entitlements (SAVE) System– May 19, 2009

URGENT!!

Deadline Extended to May 22, 2009 for Submission of Information for Access to the SYSTEMATIC ALIEN VERIFICATION FOR ENTITLEMENTS (SAVE) System

NOTE: Please disregard this message if you already responded. Do NOT resubmit and please do NOT call to see if your information was received. Unless you received an email failure message, your information was received and is being processed.

On May 8, 2009, the Department of Housing and Urban Development (HUD) sent out a RHIP Listserv message and an iMAX mail message requesting property owners or management agents to designate one person for each HUD assisted property they own or manage who will need to use the SAVE system to verify the citizenship status of applicants or tenants who are noncitizens and who claim eligible immigration status.

HUD is excited about the opportunity to get as many of its assisted properties access to the SAVE system as possible and have **extended the deadline to May 22, 2009**, in an effort to make this happen.

Why should you designate someone to get access to the SAVE System?

To ensure that HUD's rental assistance is provided only to eligible noncitizens, owners and management agents **must** use the SAVE system to verify the validity of citizenship documents provided by applicants or tenants who are noncitizens and who claim eligible immigration status.

I don't have any noncitizen tenants and never get any noncitizen applicants. Why should my property get access to the SAVE system?

There is always a chance that a noncitizen will apply to live in your property. Since the SAVE system is required to verify the validity of citizenship documents should this occur, it is best to be prepared and get access now.

What you need to do:

- 1) Fill in each column on the attached excel spreadsheet for the person designated to have access to the SAVE system.
- 2) Send it by email to SAVEaccess@hud.gov.
- 3) The deadline for submission is **May 22, 2009**.

HUD will compile the information received and forward it to DHS by June 5, 2009, for uploading into the SAVE system. After the uploading is completed (on or around June 14, 2009), each person that has been uploaded into the SAVE system will receive an email with their User ID and temporary password to access the SAVE system.

Already have access to SAVE?

Due to the fact that DHS is streamlining the SAVE database, if your property already has access to the SAVE system, you still need to designate one person to have access and complete the information requested above by the established deadline so that this person will receive a new User ID and temporary password. We apologize for any inconvenience this may cause you.

Need more than one person to have access to SAVE?

If your property has access to SAVE now and more than one person has access, or if your property does not have access to SAVE currently and you need more than one person to have access, additional people can be provided access through a manual process that will take place at HUD after June 15, 2009. Further instructions will be forthcoming prior to June 15, 2009.

If you have any questions regarding this request you may contact Kevin Garner at (202) 402-2057 or (202) 708-3000.

ExcelAttachment LS155.xlsx required with this posting.

**#154 – Reminder of Upcoming Change to Requirements for Resident Disclosure of SSN's–
May 13, 2009**

**REMINDER OF UPCOMING CHANGE TO REQUIREMENT FOR
RESIDENT DISCLOSURE OF SOCIAL SECURITY NUMBERS**

On January 27, 2009, a Final Rule was published in the Federal Register, the effective date of which was subsequently delayed to September 30, 2009, made a revision to HUD's regulations at 24 C.F.R. 5.216 covering the requirements for disclosure of social security numbers. The revision to the regulation requires disclosure of social security numbers by **all** individuals applying for or participating in HUD's rental assistance programs. Once the Final Rule is in effect, applicants will be required to disclose and provide verification of the social security number for all members of their household before they can be admitted. Current residents will be required to disclose and provide verification of social security numbers for all members of their household, where disclosure and verification has not occurred, at the time of their next interim or annual recertification.

Owners and management agents are encouraged to begin and continue informing applicants and residents who have not disclosed their social security number, or the social security number of a child under the age of 6, or who have certified they do not have a social security number, of this upcoming revision to the regulations and their need to begin the process of obtaining a social security number.

In addition to the above, owners and management agents who have access to the Enterprise Income Verification (EIV) system should be verifying and correcting social security numbers for individuals listed on the Failed EIV Pre-screening and the Failed Verification Report as having invalid social security numbers.

#153 – Follow-up Information to Posting #152 Regarding SAVE– May 8, 2009

In the Listserv posting #152 on May 8, 2009, a chart was included in the message.

The chart provided is fillable and can be submitted via email. *However*, for those who are unable to post information in the chart, please provide the required information in non-chart format via email and send to: SAVEACCESS@hud.gov.

****All emails must be sent to SAVEACCESS@hud.gov.****

No faxed or scanned information will be accepted.

URGENT!!

**REQUEST FOR INFORMATION NEEDED TO PROVIDE YOUR PROPERTY WITH ACCESS
TO THE
SYSTEMATIC ALIEN VERIFICATION FOR ENTITLEMENTS (SAVE) SYSTEM**

This notice is important for owners and management agents administering assisted properties through the Department of Housing and Urban Development (HUD). HUD is requesting contact information for one person per HUD assisted property that needs access to the SAVE system.

SAVE is a web-based automated verification system owned by the Department of Homeland Security (DHS) that consists of immigration status verification information. Authorized users of HUD's Enterprise Income Verification (EIV) system who are also authorized to use the SAVE system will be able to access SAVE from EIV later this year.

Owners and management agents **must** use the SAVE system to verify the validity of citizenship documents provided by applicants or tenants who are noncitizens and who claim eligible immigration status. This is to ensure that HUD's rental assistance is provided only to eligible noncitizens. For reference, see Chapter 3, Paragraph 3-12.L of HUD Handbook 4350.3 REV-1, *Occupancy Requirements of Multifamily Subsidized Housing Programs*.

DHS is streamlining the SAVE database and providing HUD with a one-time opportunity to ensure that all of its assisted properties have access to the SAVE system. In order to do this, HUD needs the owner or management agent to designate one person for each HUD assisted property they own or manage who will need to use the SAVE system to verify the citizenship status of applicants or tenants who are noncitizens and who claim eligible immigration status.

What you need to do:

- 1) Fill in each column on the [chart below](#) for the person designated to have access to the SAVE system.
- 2) Send it by email to: SAVEACCESS@hud.gov
- 3) The deadline for submission is **May 15, 2009**.

HUD will compile the information received and forward it to DHS by June 5, 2009, for uploading into the SAVE system. After the uploading is completed (on or around June 14, 2009), each person that has been uploaded into the SAVE system will receive an email with their User ID and temporary password to access the SAVE system.

Already have access to SAVE?

Due to the fact that DHS is streamlining the SAVE database, if your property already has access to the SAVE system, you still need to designate one person to have access and complete the

information requested above by the established deadline so that this person will receive a new User ID and temporary password. We apologize for any inconvenience this may cause you.

Need more than one person to have access to SAVE?

If your property has access to SAVE now and more than one person has access, or if your property does not have access to SAVE currently and you need more than one person to have access, additional people can be provided access through a manual process that will take place at HUD after June 15, 2009. Further instructions will be forthcoming prior to June 15, 2009.

If you have any questions regarding this request you may contact Kevin.X.Garner@hud.gov, or via telephone at (202) 402-2057.

Property Name	Address 1	Address 2	City	State Code

Zip Code	Last Name	First Name	Phone Number	Fax Number	Email Address

URGENT!!

REQUEST FOR INFORMATION NEEDED TO PROVIDE YOUR PROPERTY WITH ACCESS TO THE SYSTEMATIC ALIEN VERIFICATION FOR ENTITLEMENTS (SAVE) SYSTEM

This notice is important for owners and management agents administering assisted properties through the Department of Housing and Urban Development (HUD). HUD is requesting contact information for one person per HUD assisted property that needs access to the SAVE system.

SAVE is a web-based automated verification system owned by the Department of Homeland Security (DHS) that consists of immigration status verification information. Authorized users of HUD's Enterprise Income Verification (EIV) system who are also authorized to use the SAVE system will be able to access SAVE from EIV later this year.

Owners and management agents **must** use the SAVE system to verify the validity of citizenship documents provided by applicants or tenants who are noncitizens and who claim eligible immigration status. This is to ensure that HUD's rental assistance is provided only to eligible noncitizens. For reference, see Chapter 3, Paragraph 3-12.L of HUD Handbook 4350.3 REV-1, *Occupancy Requirements of Multifamily Subsidized Housing Programs*.

DHS is streamlining the SAVE database and providing HUD with a one-time opportunity to ensure that all of its assisted properties have access to the SAVE system. In order to do this, HUD needs the owner or management agent to designate one person for each HUD assisted property they own or manage who will need to use the SAVE system to verify the citizenship status of applicants or tenants who are noncitizens and who claim eligible immigration status.

What you need to do:

- 1) Fill in each column on the [chart below](#) for the person designated to have access to the SAVE system.
- 2) Send it by email to: SAVEACCESS@hud.gov
- 3) The deadline for submission is **May 15, 2009**.

HUD will compile the information received and forward it to DHS by June 5, 2009, for uploading into the SAVE system. After the uploading is completed (on or around June 14, 2009), each person that has been uploaded into the SAVE system will receive an email with their User ID and temporary password to access the SAVE system.

Already have access to SAVE?

Due to the fact that DHS is streamlining the SAVE database, if your property already has access to the SAVE system, you still need to designate one person to have access and complete the information requested above by the established deadline so that this person will receive a new User ID and temporary password. We apologize for any inconvenience this may cause you.

Need more than one person to have access to SAVE?

If your property has access to SAVE now and more than one person has access, or if your property does not have access to SAVE currently and you need more than one person to have access, additional people can be provided access through a manual process that will take place at HUD after June 15, 2009. Further instructions will be forthcoming prior to June 15, 2009.

If you have any questions regarding this request you may contact Kevin.X.Garner@hud.gov, or via telephone at (202) 402-2057.

Property Name	Address 1	Address 2	City	State Code

Zip Code	Last Name	First Name	Phone Number	Fax Number	Email Address

**Attention Enterprise Income Verification (EIV)
Multifamily Housing Program Users**

Multifamily EIV Website Update

The **EIV System Updates for Multifamily Housing Program Users** web page, located at: <http://www.hud.gov/offices/hsg/mfh/rhiip/eiv/sysupdates.cfm>, has been updated to include a listing and description of “What’s New in EIV 8.1.2,” which was deployed on April 24, 2009, and made available to users on April 27, 2009. In general, enhancements and fixes to the system include technical and functional corrections to make the system more user-friendly. For example, the Failed Verification Report is more appropriately made available via the Verification Report module and the User Request module now includes an option to sort by the date received. Future enhancements for the EIV 8.2 Release, scheduled for September 11, 2009, will make other functional changes to the system as EIV becomes mandatory for use by Multifamily owners and management agents, effective September 30, 2009. Once requirements for the next release become operational, they will be posted to the site, as well.

The **Multifamily Housing Program Requirements and Guidance for Using EIV** web page, located at: <http://www.hud.gov/offices/hsg/mfh/rhiip/eiv/reqnguide.cfm> was also updated to include additional source documents, for example, federal register notices for the EIV system of records and computer matching program. Also added was the federal register notice, dated March 27, 2009, concerning the new Refinement of Income and Rent Determination Requirements Final Rule that becomes effective September 30, 2009.

Other web pages, such as the **EIV Training and Outreach for Multifamily Housing Programs**, will be updated to include information on the next EIV Instructional Course once the details have been finalized.

Thank you for your interest in HUD’s EIV System and for assisting the Department to further reduce income and rent determination errors through continued and regular use of the system.

#150 - Correction to Posting #149 - New Page Changes Issued to the Section 8 Renewal Policy Guide– April 21, 2009

This is a correction to posting #149, Item g. regarding the website of the Section 8 Renewal Help Desk Contacts. The correct link to the Section 8 Renewal Help Desk Contacts is as follows: <http://www.hud.gov/offices/hsg/mfh/exp/helpdesk.cfm>.

More New Page Changes to the Section 8 Renewal Policy Guide Issued

On April 17, 2009, Brian D. Montgomery, Assistant Secretary for Housing-Federal Housing Commissioner, approved a set of new page changes to the Section 8 Renewal Policy Guide. The page changes include:

- a. Section 7-9, Preservation Updates, has been added to Chapter 7. It discusses shallow rent subsidy and new debt in a budget-based rent increase.
- b. Section 16-1.C.2. has been updated to clarify when more than one rent adjustment is permitted.
- c. Section 16-2, REMS Reporting, has been removed and the remaining sections of Chapter 16 are renumbered.
- d. The new Section 16-3 contains a clarification concerning the use of the debt service associated with the current financing when computing an OCAF rent adjustment.
- e. Appendix 15-2 has been revised to be an Addendum to the Renewal Contract.
- f. Attachment 1, Acronyms, has been updated.
- g. Attachment 7, Section 8 Renewal Help Desk Contacts, is being removed. The Department maintains an up-to-date list of Section 8 Renewal Help Desk Contacts on the web at: <http://www.hud.gov/officec/hsg/mfh/mfhsec8.cfm>

The changes have been posted to <http://www.hud.gov/offices/hsg/mfh/mfhsec8.cfm>

More New Page Changes to the Section 8 Renewal Policy Guide Issued

On April 17, 2009, Brian D. Montgomery, Assistant Secretary for Housing-Federal Housing Commissioner, approved a set of new page changes to the Section 8 Renewal Policy Guide. The page changes include:

- a. Section 7-9, Preservation Updates, has been added to Chapter 7. It discusses shallow rent subsidy and new debt in a budget-based rent increase.
- b. Section 16-1.C.2. has been updated to clarify when more than one rent adjustment is permitted.
- c. Section 16-2, REMS Reporting, has been removed and the remaining sections of Chapter 16 are renumbered.
- d. The new Section 16-3 contains a clarification concerning the use of the debt service associated with the current financing when computing an OCAF rent adjustment.
- e. Appendix 15-2 has been revised to be an Addendum to the Renewal Contract.
- f. Attachment 1, Acronyms, has been updated.
- g. Attachment 7, Section 8 Renewal Help Desk Contacts, is being removed. The Department maintains an up-to-date list of Section 8 Renewal Help Desk Contacts on the web at: <http://www.hud.gov/officcec/hsg/mfh/mfhsec8.cfm>

The changes have been posted to <http://www.hud.gov/offices/hsg/mfh/mfhsec8.cfm>
. (Check posting 150 for corrected link)

#148 - Detailed PowerPoint Slide Presentation from December 2008 EIV 8.1.1 Instructional Course; Listserv Archive Updated– April 20, 2009

Comprehensive Slides Posted from December 16-17, 2008 Enterprise Income Verification (EIV) System Webcast

The EIV Training and Outreach for Multifamily Housing Programs website <http://www.hud.gov/offices/hsg/mfh/rhiip/eiv/eivtraining.cfm> has been updated to include a more detailed version of the original Microsoft PowerPoint slide presentation presented during the EIV 8.1.1 Instructional Course, conducted via webcast on December 16 and 17, 2008 by HUD staff from the Office of Housing Assistance and Grant Administration (HAGA). These slides are intended to provide further information and greater detail to assist in the understanding of the EIV system along with instruction on access, security, and use of the system.

To view the in-depth, two-day EIV 8.1.1 Instructional Course, go to the “EIV Training and Outreach for Multifamily Housing Programs” web page and click HUD Webcast, which will take you to the “Webcast” page. In the first paragraph, click the link for “archive”, click the link for “Multifamily”, and click the link for “Enterprise Income Verification” to view the “Multifamily Enterprise Income Verification, December 16-17, 2008” course. You may email Kevin Garner at Kevin.X.Garner@hud.gov with any questions you have on posted materials or presentations delivered during the course. Questions and answers (Q&As) on the subject course will be posted soon.

Updated Multifamily RHIP Listserv Archive

The RHIP Listserv archive has a new look and has recently been updated to include all postings from #1 thru #147. You can view the archive at <http://www.hud.gov/offices/hsg/mfh/rhiip/mfhrhiip.cfm> under “**Listserv - Multifamily RHIP Tips**”. The archive document is now available in pdf format and has a “BOOKMARK” feature on the left side of the screen that serves as the “TABLE OF CONTENTS”. If you “click” on a particular posting in the “TABLE OF CONTENTS”, that posting selected will appear. Users can also search the entire pdf file by key word. The listserv archive will be updated every 10 postings.

Section 8 Renewal Policy Guide Page Changes Issued

On April 13, 2009, Brian Montgomery, Assistant Secretary for Housing – Federal Housing Commissioner, authorized the release of a new set of page changes to the Section 8 Renewal Policy Guide. A complete copy of the changes will be posted to the web at: <http://www.hud.gov/offices/hsg/mfh/mfhsec8.cfm>

The changes cover the following:

- a. Chapter 4, Option Two Contract Renewals for Other Projects with Current Rents At or Below Comparable Market Rents, has been updated. The revision includes two major changes:
 - Permits increased distributions to for-profit owners that have or are willing to enter into long term Section 8 contracts.
 - Directs the Owner to use the project's current debt service when preparing a budget-based rent increase.
- b. The opening paragraph of Chapter 14, RHS Section 515/8, is revised to clarify that RHS projects are not eligible for a debt restructuring under MAHRA.
- c. Attachment 2, Glossary of Terms, has been updated.
- d. Four new forms are being added to the Guide. The four collateral assignment forms have been revised to require signature by HUD rather than by HUD or the PHA CA. These forms are to be used verbatim, i.e., without any alteration of any kind to the language or form.

The forms show that HUD has provided written consent permitting the owner to assign the HAP contract.

- Attachment 21, Consent to Assignment of HAP Contract as Security for Financing.
- Attachment 22, Consent to Assignment of HAP Contract as Security for FNMA Financing.
- Attachment 23, Consent to Assignment of HAP Contract as Security for FREDDIE MAC Financing.
- Attachment 24, Consent to Assignment as Security For FNMA Credit Enhancement

**HUD Seeks Input on Low Income Housing Tax Credit (LIHTC)
Tenant Data Collection Requirement**

The Housing and Economic Recovery Act of 2008 (HERA) requires state agencies administering properties receiving LIHTCs to submit to HUD, not less than annually, certain demographic and economic information on households residing in such properties. This statute also requires HUD to establish standards and definitions for the information that state housing agencies must submit, and to provide them with technical assistance in establishing systems to compile and submit such information. A Notice was published in the March 30, 2009, Federal Register whereby HUD is seeking early input from applicable state agencies, and other interested stakeholders, on a methodology or approach to meet this statutory requirement. Interested parties have until May 29, 2009, to provide comments.

A copy of the March 30, 2009 Federal Register is located at:
<http://edocket.access.gpo.gov/2009/pdf/E9-7041.pdf>.

#145 - Delay in Effective Date of the Refinement of Income and Rent Determination Requirements Final Rule - March 27, 2009

---IMPORTANT NOTICE---

**DELAY IN EFFECTIVE DATE OF THE
REFINEMENT OF INCOME AND RENT DETERMINATION REQUIREMENTS FINAL RULE**

A delay in the effective date of the Refinement of Income and Rent Determination Requirements Final Rule was published in the Federal Register today, March 27, 2009. The rule, originally scheduled to be effective on March 30, 2009, **will be effective on September 30, 2009.**

One of the provisions in the Final Rule published in the Federal Register on January 27, 2009, is making use of the Enterprise Income Verification (EIV) system mandatory. While all other provisions of the Final Rule were to be effective on March 30, 2009, multifamily owners and management agents were to be provided an additional six months, to September 30, 2009, to implement use of the EIV system. The Department has determined that a further delay in the mandatory use of EIV beyond September 30, 2009, by multifamily owners and management agents is not necessary. Therefore, **the use of EIV will also become mandatory for multifamily owners and management agents effective September 30, 2009.**

To learn more about the Final Rule:

Refinement of Income and Rent Determination Requirements in Public and Assisted Housing Programs – **Final Rule** published in the January 27, 2009 Federal Register is located at: <http://edocket.access.gpo.gov/2009/pdf/E9-1248.pdf>. The **proposed delay** in the effective date and information relating to non-citizens published in February 11, 2009 Federal Register is located at: <http://edocket.access.gpo.gov/2009/pdf/E9-3004.pdf>.

Refinement of Income and Rent Determination Requirements in Public and Assisted Housing Programs – **Final Rule Delay of Effective Date** published in the Federal Register on March 27, 2009 is located at: <http://edocket.access.gpo.gov/2009/pdf/E9-6942.pdf>

For information on EIV:

To learn more about obtaining access to and using the EIV system go to the Multifamily EIV website at: <http://www.hud.gov/offices/hsg/mfh/rhiip/eiv/eivhome.cfm>.

#144 - Revision to Posting #143 RE: Extension for Submission of Financial Statements for Projects with FYE 12/31/08 - March 27, 2009

Extension for Submission of Financial Statements for Projects with a Fiscal Year Ending on 12/31/2008

REVISED: Due to HUD infrastructure performance problems, MF property owners have experienced difficulties submitting their financial statements due March 30, 2009 (for owners with a fiscal year end = 12/31). The Office of Multifamily Housing Programs, Office of Asset Management has authorized REAC to implement a blanket 30 day extension for owners whose project fiscal year ends 12/31/2008 only. Owners/auditors should not request an extension in FASS; the extension has been automatically implemented. The extended FASS due date is 04/30/2009. Owners who submit the financial statements on or before 4/30/2009 will not be referred to the Departmental Enforcement Center or be flagged in the Active Partners Performance System. **Please contact the Real Estate Assessment Center (REAC) Technical Assistance Center (TAC) on 1-888-245-4860 or via email REAC_TAC@HUD.GOV for assistance or further guidance.**

**#143 - Extension for Submission of Financial Statements for Projects with FYE 12/31/08 -
March 26, 2009**

**Extension for Submission of Financial Statements for Projects with a Fiscal Year Ending
on 12/31/2008**

Due to HUD infrastructure performance problems, Multifamily property owners have experienced difficulties submitting their financial statements due March 30, 2009 (for owners with a fiscal year end (FYE) = 12/31). The Office of Multifamily Housing Programs, Office of Asset Management has authorized the Real Estate Assessment Center (REAC) to implement a blanket **30 day extension for owners whose project fiscal year ends 12/31/2008 only**. Owners/auditors should not request an extension in the Financial Assessment Sub System (FASS); the extension has been automatically implemented. **The extended FASS due date is 04/30/2009**. Owners who submit the financial statements on or before 4/30/2009 will not be referred to the Departmental Enforcement Center or be flagged in the Active Partners Performance System.

**#142 - Funding No Longer Available for the Emergency Capital Repair Grant Program -
March 5, 2009**

Funding No Longer Available for the Emergency Capital Repair Grant Program

Effective midnight on March 5, 2009, grant applications submitted by eligible non-profit owners for projects designated for the elderly under the Emergency Capital Repair Grant Program will no longer be accepted in Grants.gov. Grant funding is no longer available for this program under the Notice of Funding Availability published in the Federal Register on November 24, 2008.

Reminder!

Notice of Proposed Delay to the Effective Date for the Refinement of Income and Rent Determination Requirements in Public and Assisted Housing Programs Final Rule

Public comments are due on or before March 13, 2009.

As a reminder, a Notice of Proposed Delay in Effective Date for the Refinement of Income and Rent Determination Requirements in Public and Assisted Housing Programs final rule was published in the Federal Register on February 11, 2009. The Notice requests public comment on a 60-day delay in the March 30, 2009, effective date and the delayed September 30, 2009, effective date for the Enterprise Income Verification (EIV) system to be mandatory for multifamily housing program users. The Notice also solicits comments generally on the final rule itself.

Instructions on how to make comments are located in the Notice.

A link to the Notice that will be published in the Federal Register may be found under What's New on the Multifamily Housing website at: <http://www.hud.gov/offices/hsg/hsgmulti.cfm>.

Enterprise Income Verification (EIV) News Update for Multifamily Housing Program Users!

Check it out! The EIV website for multifamily housing programs has been updated to include a new “Multifamily Housing Program Requirements and Guidance for Using EIV” web page, as an easy reference to program requirements and guidance relative to EIV. Existing pages such as the main “Enterprise Income Verification (EIV) System for Multifamily Housing Program Users” page and the “EIV System Updates for Multifamily Housing Program Users” page have also been updated to 1) clarify the use of EIV, authorized users and their purpose in using the system and/or viewing information obtained from the EIV system, and 2) provide status updates on the system and its contents. Please visit our EIV website at: <http://www.hud.gov/offices/hsg/mfh/rhiip/eiv/eivhome.cfm> to access and view current updates.

The “EIV Training and Outreach for Multifamily Housing Programs” web page <http://www.hud.gov/offices/hsg/mfh/rhiip/eiv/eivtraining.cfm> is in the process of being updated, as well, to include the comprehensive version of materials used for the EIV 8.1.1 Instructional Course, held December 16-17, 2008 via Webcast. To view the in-depth, two-day EIV 8.1.1 Instructional Course, conducted December 16-17, 2008 by HUD staff from the Office of Housing Assistance and Grant Administration (HAGA), go to the “EIV Training and Outreach for Multifamily Housing Programs” web page and click HUD Webcast, which will take you to the “Webcast” page. In the first paragraph, click the link for “archive” to view the “Multifamily Enterprise Income Verification, December 16-17, 2008” course located under “Most Recent Webcasts.” You may email Kevin Garner at Kevin.X.Garner@hud.gov with any questions you have on posted materials or presentations delivered during the course. Questions and answers (Q&As) on the subject course and the comprehensive version of the course materials will be posted to the page in the coming weeks.

Thank you for your interest in HUD’s EIV system and for continuously assisting the Department to achieve its goal of reducing errors in the administration of HUD’s rental assistance programs.

NEW FEDERAL REGISTER POSTINGS OF INTEREST

· On February 11, 2009, a Notice of Proposed Delay in Effective Date of the Final Rule entitled, "Rent Refinement and Income Determination Requirements in Public and Assisted Housing" was published. The Notice requests public comment on a 60-day delay in the March 30, 2009, effective date and the already delayed September 30, 2009, effective date for the Enterprise Income Verification (EIV) system to be mandatory for multifamily housing program users. The Notice also solicits comments generally on the final rule itself.

In addition, clarification is made in the Notice that the final rule requirements on the use of social security numbers for determining program eligibility do not apply to individuals in mixed families who do not contend eligible immigration status under HUD's noncitizen regulations.

Although the effective date may be delayed, owners and management agents are encouraged to begin informing applicants and tenants who have not disclosed their social security number, or the social security number of a child under the age of 6, or who have certified they do not have a social security number, of this upcoming revision to the regulations and their need to begin the process of obtaining a social security number.

In addition to the above, owners and management agents who have access to the Enterprise Income Verification (EIV) system should be verifying and correcting social security numbers for individuals listed on the Failed EIV Pre-screening and the Failed Verification Report as having invalid social security numbers.

· On January 22, 2009, a Notice of Information Collection: Supplemental Information to Application for Assistance Regarding Identification of Family Member, Friend or Other Person or Organization Supportive of a Tenant for Occupancy in HUD Assisted Housing, was published. The Notice requires owners/management agents to give an individual or family applying for assisted housing the option to provide as part of their application for occupancy the name, address, phone number, and other relevant information of a family member, friend or person associated with a social, health, advocacy, or similar organization, who is familiar with and may assist with the services and special care needed by the individual or family, and assist in resolving any tenancy issues arising during the tenancy of such tenant. This implements Section 644 of the Housing and Community Development Act of 1992 (42 U.S.C. 13604). Comments on the Notice are due March 23, 2009. A copy of the Federal Register is located at:

<http://edocket.access.gpo.gov/2009/pdf/E9-1165.pdf>

· On January 15, 2009, the Final Rule on Civil Money Penalties: Certain Prohibited Conduct was published. This Final Rule revises HUD's regulations that govern the imposition of civil money penalties. A copy of the Final Rule is located at:

<http://edocket.access.gpo.gov/2009/pdf/E9-851.pdf>

· On January 12, 2009, a Notice of the Revised Contract Rent Annual Adjustment Factors (AAFs) for 2009 was published. The AAFs are used to adjust the contract rents on the anniversary date of the assistance contract for some multifamily projects. The AAFs are effective January 12, 2009. A copy of the Federal Register containing the revised AAFs is located at:

<http://edocket.access.gpo.gov/2009/pdf/E9-374.pdf>

RHHP Tip: Tenant's Refusal to Sign Consent Forms

If the applicant or tenant, or any adult member of the applicant's or tenant's family, does not sign and submit the consent form as required in 24 CFR 5.230, the following statements apply:

1. The owner must deny assistance and admission to the applicant; or
2. The owner must terminate assistance to the tenant (see paragraph 8-5 regarding terminations).

For more information on consent and verification forms, please refer to Chapter 3, Paragraph 3-11 of HUD Handbook 4350.3 REV-1 *Occupancy Requirements of Subsidized Multifamily Housing Programs*.

**#138 – Proposed Delay (Final Rule on Refinement of Income & Rent Determination) -
February 10, 2009**

**Proposed Delay in Effective Date for Refinement of Income and Rent Determination Final
Rule**

A Notice of Proposed Delay in Effective Date for the Refinement of Income and Rent Determination Requirements in Public and Assisted Housing Programs final rule is being published in the Federal Register on February 11, 2009. The Notice requests public comment on a 60-day delay in the March 30, 2009, effective date and the delayed September 30, 2009, effective date for the Enterprise Income Verification (EIV) system to be mandatory for multifamily housing program users. The Notice also solicits comments generally on the final rule itself.

In addition, clarification is made in the Notice that the final rule requirements on the use of social security numbers for determining program eligibility do not apply to individuals in mixed families who do not contend eligible immigration status under HUD's noncitizen regulations.

A link to the Notice that will be published in the Federal Register may be found under What's New on the Multifamily Housing website at: <http://www.hud.gov/offices/hsg/hsgmulti.cfm>.

**Correction to Listserv #135 – Revised Definition of Annual Income in Final
Rule Published on January 27, 2009**

It has come to our attention that Listserv #135 issued on January 29, 2009, incorrectly described the change to the definition of annual income in the Final Rule entitled, "Refinement of Income and Rent Determination in Public and Assisted Housing Programs." In order that there be no confusion, the definition is repeated here directly from the final rule, as follows:

Annual income is now defined as all amounts, monetary or not, which:

1) Go to, or on behalf of, the family head or spouse (even if temporarily absent) or to any other family member; and

2) Are based on, at the time of admission, reexamination, or recertification:

(i) Actual income being received (projected forward for a 12-month period) or

(ii) Past actual income received or earned within the last 12 months of the determination date, as HUD may prescribe in applicable administrative instructions when:

(A) The family reports little or no income; and

(B) The processing entity is unable to determine annual income due to fluctuations in income (e.g., seasonal or cyclical income).

(3) Which are not specifically excluded in paragraph (e) of this section.

(4) Annual income also means amounts derived (during the 12-month period) from assets to which any member of the family has access.

Please note that paragraph (e) referred to in (3) above is currently 5.609(c) of the existing regulation which describes the exclusions to annual income. Once the final rule is effective, 5.609(c) will become 5.609(e).

The Department apologizes for any confusion the earlier issued Listserv message may have caused.

Delegated Processing Procedures (Draft) Notice

The Office of Multifamily has placed a draft of the Delegated Processing Housing Notice and its Appendices on the Internet for public comment until March 5, 2009. The web address is:

<http://www.hud.gov/offices/hsg/mfh/gendocs/delegate/draftdelegatedprocessing.cfm>

Information in this draft is subject to change. The final official Housing Notice will be published on **HUDCLIPS**, after all comments have been reviewed, changes made, HUD clearance procedures followed, and the final official notice is signed by the Assistant Secretary for Housing/Federal Housing Commissioner.

Please email questions, comments, and suggestions concerning the following draft materials to **Kerry.J.Mulholland@hud.gov**.

#135 – Final Rule on Income & Rent Determination Requirements; RHIP Tip (Extremely Low-income Requirements) - January 29, 2009

It's Here!

The Refinement of Income and Rent Determination Requirements in Public and Assisted Housing Programs Final Rule Published

The Refinement of Income and Rent Determination Requirements in Public and Assisted Housing Programs Final Rule was published in the Federal Register on January 27, 2008, and can be found at <http://edocket.access.gpo.gov/2009/pdf/E9-1248.pdf>. The main changes are as follows:

The final rule requires **all** individuals applying for or participating in HUD's rental assistance programs to have a valid social security number. All social security numbers for an applicant's household must be verified using appropriate documentation before the household may be admitted into the project. For current tenants, all social security numbers must be provided and verified at the next interim or regularly scheduled recertification. All efforts should be made to ensure current tenants and those on the waiting list are aware of this new requirement that will take effect on March 30, 2009.

The final rule has also revised the definition of annual income. Instead of using anticipated income, owners and management agents (O/As) will use actual past income and will have the discretion to use projected future income under certain circumstances in order to calculate annual income. This change will also take effect on March 30, 2009.

Beginning on March 30, 2009, O/As will be required to obtain verification of a signed declaration of U.S. citizenship or U.S. nationality.

The final rule also makes the use of HUD's Enterprise Income Verification (EIV) system mandatory for multifamily O/As as of September 30, 2009. Those O/As who do not currently have access to the EIV system should obtain access as soon as possible and become familiar with using the system. Information on applying for access to the EIV system for Multifamily users is available at: <http://www.hud.gov/offices/hsg/mfh/rhiip/eiv/eivhome.cfm>.

RHIP TIP: Extremely Low-Income Targeting Requirements for Section 8 Units

When an extremely low-income applicant is needed to achieve income targeting requirements, and the next applicant on the waiting list has income above the extremely low-income limit, that applicant must be returned to the waiting list. When returned to the waiting list, a notation must be made indicating why this applicant was returned to the list rather than housed or withdrawn.

For more information on extremely low-income targeting, please refer to Chapter 4, Paragraph 4-15.D of HUD Handbook 4350.3 REV-1 *Occupancy Requirements of Subsidized Multifamily Housing Programs*.

#134 –COLA for 2009; EIV Instructional Course Materials and Q&A's; and RHIP Tip (Moving Tenants Who Require Special Features into Accessible Units) - January 9, 2009

Enterprise Income Verification (EIV) System

Update for Multifamily Housing Program Users

Cost-of-Living Adjustment (COLA) for 2009. On January 06, 2009, the COLA for beneficiaries of Social Security (SS) and Supplemental Security Income (SSI) benefits from the Social Security Administration (SSA) was loaded into EIV. The new benefit amounts, reflecting the 5.8 percent COLA increase for participant families, are displayed on the EIV Income Report.

EIV 8.1.1 Instructional Course – Materials. In the coming weeks, the comprehensive version of materials used for the EIV 8.1.1 Instructional Course, held December 16-17, 2008 via Webcast will be posted to the **EIV Training and Outreach for Multifamily Housing Programs** web page at: <http://www.hud.gov/offices/hsg/mfh/rhiip/eiv/eivtraining.cfm>. Course materials will include detailed information not included on the slides used for the presentation. An “EIV Update” RHIP Listserv message will be posted to inform you of the availability of updated materials for review and download.

To view the in-depth, two-day EIV 8.1.1 Instructional Course, conducted December 16-17, 2008 by HUD staff from the Office of Housing Assistance and Grant Administration (HAGA), go to the **EIV Training and Outreach for Multifamily Housing Programs** web page and click HUD Webcast, which will take you to the “Webcast” page. In the first paragraph, click the link for “archive” to view the “Multifamily Enterprise Income Verification, December 16-17, 2008” course located under “Most Recent Webcasts.” You may email Kevin Garner at Kevin_X_Garner@hud.gov with any questions you have on posted materials or presentations delivered during the course.

EIV 8.1.1 Instructional Course – Questions and Answers (Q&As). Questions received via email, during and after the live Webcast, will be answered and posted to the **EIV Training and Outreach for Multifamily Housing Programs** web page, along with the updated course materials. Q&As will be listed and categorized by subject (e.g., EIV access, security, use of EIV reports, verification, monitoring, etc.) to make user friendly. As with the updated course materials, an “EIV Update” RHIP Listserv message will be posted informing you of the availability of the Q&As.

Thank you for your interest in, and use of, HUD’s EIV System, which will assist the Department in reducing income and rent determination errors in HUD’s rental assistance housing programs.

RHIP TIP: Moving Tenants Who Require Special Features into Accessible Units

If a member of a tenant household becomes disabled with an impairment that requires special accessibility features and the tenant requests an accessible unit, an owner may move that tenant into an accessible unit in lieu of making the tenant’s existing unit accessible and usable. (See Chapter 4 of Handbook 4350.3 REV-1 for more information.) However, if a tenant needs only minor modifications to his or her unit, and does not need a fully accessible unit, the landlord should make the modifications and leave the project’s fully accessible units available for tenants who need such units.

For more information on moving tenants who require special features into accessible units, please refer to Chapter 2, Paragraph 2-33 of HUD Handbook 4350.3 REV-1 *Occupancy Requirements of Subsidized Multifamily Housing Programs*.

General Section of the Fiscal Year 2009 Notice of Funding Availability Published

The attached General Section of the Fiscal Year 2009 Notice of Funding Availability (NOFA) was published in the Federal Register on December 29, 2008. The General Section is designed to help potential applicants become familiar with the FY 2009 application process in advance of publication of the FY 2009 NOFAs for the HUD's various discretionary programs. The General Section also provides a projected schedule of when the different program NOFAs will be published.

HUD will also be conducting a General Section satellite broadcast on January 7, 2009 from 11:00 AM to 1:00 PM eastern time. The broadcast will cover the following items:

- Overview of the General Section
- Change to the SuperNOFA process
- Estimated timeframe for release of NOFAs - Appendix A
- Signing up for the RSS Feed to receive funding opportunity notifications from Grants.gov
- Timely Receipt of Applications
- Changes to the Logic Model for FY 2009
- HUD's Logic Model Performance Page website.

The broadcast will be archived for future viewing for persons who miss the live showing.

<<09_GeneralSection.pdf>>



Federal Register

**Monday,
December 29, 2008**

Part II

Department of Housing and Urban Development

**Notice of HUD's Fiscal Year (FY) 2009
Notice of Funding Availability (NOFA);
Policy Requirements and General Section
to HUD's FY2009 NOFAs for Discretionary
Programs; Notice**

**DEPARTMENT OF HOUSING AND
URBAN DEVELOPMENT**

[Docket No. FR-5300-N-01]

**Notice of HUD's Fiscal Year (FY) 2009
Notice of Funding Availability (NOFA);
Policy Requirements and General
Section to HUD's FY2009 NOFAs for
Discretionary Programs**

AGENCY: Office of the Secretary, HUD.

ACTION: Notice of HUD's FY2009 NOFA Policy Requirements and General Section to HUD's FY2009 NOFAs for Discretionary Programs (notice).

SUMMARY: This notice provides prospective applicants for HUD's competitive funding with the opportunity to become familiar with the General Section of HUD's FY2009 NOFAs, in advance of publication of any FY2009 NOFAs. This year, HUD plans to publish its NOFAs as they are approved for publication and not in a combined SuperNOFA. HUD believes that by making this change, the NOFAs will be available earlier in the fiscal year. To assist applicants in this transformation, HUD is publishing the anticipated schedule for release of HUD's FY2009 NOFAs in Appendix A. The information regarding NOFA programs and schedules is subject to the availability of appropriations. As HUD receives appropriations, HUD may elect to amend the anticipated dates, estimated funds available, and/or program requirements that may appear in the published NOFAs to reflect HUD's FY2009 appropriations act, when enacted by Congress. Any amendment to HUD published NOFAs will be made available to the public through a **Federal Register** publication and published on <http://www.grants.gov>. Applicants are urged to sign up for Grants.gov's RSS Feed service to receive any changes to this General Section to HUD's FY2009 NOFAs. Information about the RSS Feed Service can be found at <http://www07.grants.gov/help/rss.jsp>. Detailed instructions on use of the RSS Feed can be found later in this General Section.

Applicants are advised to become familiar with the requirements of this General Section, particularly with applicant Grants.gov registration requirements and submission instructions. Submission instructions must be adhered to in order to have a successful submission. Applicants are also advised to provide copies of the General Section to all persons that will be working on the application. HUD has found too often that the Program Section and the application are passed along, but not the General Section instructions;

thus placing Authorized Organization Representatives (AORs) at a disadvantage in not having all the information needed for submission.

HUD will continue to require that applicants submit their applications electronically via Grants.gov. In FY2008, HUD switched to Adobe Forms application packages, available on Grants.gov. The Adobe Forms packages take more processing power, are larger in size, and use more memory than the earlier packages used by Grants.gov. Applicants are advised to pay careful attention to the submission instructions contained in this notice. Failure to do so will result in difficulty in uploading your application and "VirusDetect" rejection notices. The Adobe Forms packages are compatible with Windows XP Windows and Windows Vista operating systems, Apple Macintosh computers, and Microsoft Office 2007. Please carefully read the instructions in this notice regarding use of Adobe Forms.

To submit an application via Grants.gov, new users will be required to complete a five-step registration process, which can take 2 to 4 weeks to complete. The process includes ensuring that information provided for the applicant organization to Dun and Bradstreet (D&B) for your DUNS number matches information previously provided by your organization and contained in Internal Revenue Service (IRS) records. If there is a discrepancy in the information, the registration cannot be completed until discrepancy issues are resolved. Applicants that have previously completed the registration process have to renew or update their registration in the Central Contractor Registration (CCR). The renewal/update process confirms that the registration information is still accurate and allows organizations to make any appropriate changes. During the renewal/update process, the CCR will check the D&B information against the IRS records for the applicant organization. If there are discrepancies, the renewal/update cannot be completed until the discrepancies are resolved. Please allow adequate time to resolve any registration issues. Failure to complete the renewal/update process in the CCR before the CCR registration expires will result in an applicant having to repeat the five steps of the registration process. If an applicant changes the eBusiness Point of Contact in the CCR registration, it should make sure the new eBusiness Point of Contact has also granted permission to the person submitting the application to be the AOR. To submit an eligible application to HUD, the AOR must be

able to enter into a legally binding agreement on behalf of the organizational entity. Please see detailed registration instructions in Section IV.B. of this notice.

HUD recommends that all prospective applicants take the time to carefully read the notice entitled "Notice of Opportunity to Register Early and other Important Information for Electronic Application Submission via Grants.gov," published on December 5, 2008 (73 FR 74179). This notice is also available on HUD's Web site at <http://www.hud.gov/offices/adm/grants/fundsavail.cfm> and on <http://www.Grants.gov>. HUD's Early Registration notice provides step-by-step instructions for applicants who must register with Grants.gov and also provides renewal/update instructions for those who have previously registered. Prospective applicants should register or update their registration information upon publication of this notice so you are prepared when the Program Section NOFAs are published. Please note that the Continuum of Care application is submitted through the HUD eSNAPS system, not Grants.gov. Submission instructions for the eSNAPS applications will be contained in the NOFA for the Continuum of Care program. Notification of the availability of the Continuum of Care NOFA and FY2009 application, and other information, will be released via the Grants.gov Web site. HUD does not maintain a mailing list with the exception of the Continuum of Care listserv for the Continuum of Care applicant community. To join the HUD homeless assistance program listserv, go to <http://www.hud.gov/subscribe/signup.cfm?listname=Homeless%20Assistance%20Program&list=HOMELESS-ASST-L>.

FOR FURTHER INFORMATION CONTACT: For further information on HUD's FY2009 Policy Requirements and General Section, contact the Office of Departmental Grants Management and Oversight, Office of Administration, Department of Housing and Urban Development, 451 7th Street, SW., Room 3156, Washington, DC 20410-5000; telephone number 202-708-0667. This is not a toll-free number. Persons with hearing or speech impairments may access this number via TTY by calling the Federal Information Relay Service at 800-877-8339.

SUPPLEMENTARY INFORMATION: Each year, HUD strives to improve its competitive funding process. To help applicants with electronic application registration

and submission, HUD is updating its Desktop User Guide for Submitting Electronic Grant Applications. The user guide will provide step-by-step details and screen shots of the entire registration and application submission process, including troubleshooting application submission errors. HUD updates the guide regularly and it will be available at <http://www.hud.gov/offices/adm/grants>.

HUD believes that early publication of the General Section is beneficial to prospective applicants by providing advance notice of the Department's threshold requirements, strategic goals, policy priorities, and other requirements applicable to almost every individual NOFA published by the Department. The General Section is structured to refer the reader to the individual program NOFAs. Although program NOFAs are not being published at this time, the references are retained. Likewise, when program NOFAs are published they will contain references to the General Section. The General Section and Program Sections comprise the NOFA instructions. Forms and narratives are used by the applicants to address the requirements contained in the instructions. When the Program Sections of the FY2009 NOFAs are published, they will be consistent with the General Section.

HUD is always interested in improving its application processes. You can help HUD improve its outreach and program NOFAs by providing feedback on ways it can improve the NOFA process. Please note that each application contains a "You Are Our Client!" questionnaire. HUD requests that you respond to this survey to let the Department know what improvements have been beneficial and to share your ideas on where improvements can continue to be made. HUD carefully considers the comments received from its clients and strives to use the comments to improve each year's NOFAs and the funding process.

This publication includes a list of programs for which NOFAs are anticipated to be published in FY2009, subject to the availability of funds. Any changes to the listing will be identified in each published program NOFA. Any changes to this General Section will be published as Technical Corrections in the **Federal Register** and on <http://www.Grants.gov>.

HUD hopes that the information contained in this General Section, and in other publications designed to assist applicants requesting funds via electronic application, is helpful to you, our applicants.

Dated: December 17, 2008.

Roy A. Bernardi,
Deputy Secretary.

Overview Information

A. *Federal Agency Name:* Department of Housing and Urban Development (HUD), Office of the Secretary.

B. *Funding Opportunity Title:* Policy requirements applicable to all HUD Notices of Funding Availability (NOFAs) published during FY2009.

C. *Announcement Type:* Initial announcement of the general policy requirements that apply to all HUD federal financial assistance NOFAs for FY2009.

D. *Funding Opportunity Number:* FR-5300-N-01.

E. *Catalog of Federal Domestic Assistance (CFDA) Number:* A CFDA number is provided for each HUD federal financial assistance program. When using "Apply Step 1" on the Grants.gov Web site to download an application, you will be asked for the CFDA number. Please refer to the CFDA number in the Grants.gov synopsis of the programs for which you wish to apply. The CFDA number is a key data element used for the application search feature of Grants.gov. Use only the CFDA number, the Funding Competition Identification Number, or the Funding Opportunity Number, when searching Grants.gov. Using more than one of these items will result in an error message indicating that the opportunity cannot be found.

F. *Dates:* The deadline dates that apply to the federal financial assistance made available through HUD's FY2009 NOFAs will be found in the published NOFAs. Appendix A to this General Section lists the programs expected to be included in HUD's FY2009 NOFAs, and their anticipated publication time frame.

G. *Additional Overview Content Information:* Unless otherwise stated, HUD's general policy requirements set forth in this notice apply to all HUD federal financial assistance made available through HUD's FY2009 NOFAs. These policies cover all NOFAs issued for FY2009 funding.

Full Text of Announcement

I. Funding Opportunity Description

This notice describes HUD's FY2009 policy requirements applicable to all of HUD's NOFAs published in FY2009. Each published NOFA will contain a description of the specific requirements for the program for which funding is made available and each will refer to applicable policies described in this General Section. Each program NOFA

will also describe additional procedures and requirements that apply to the individual program NOFA, including a description of the eligible applicants, eligible activities, threshold requirements, factors for award, variations from the General Section requirements, and any additional program requirements or limitations. To adequately address all of the application requirements for any program for which you intend to apply, please carefully read and respond to both this General Section and the individual program NOFAs.

Authority. HUD's authority for making funding available under its FY2009 programs is identified in each program NOFA.

II. Award Information

Funding Available. Each program NOFA will identify the estimated amount of funds available in FY2009 based on anticipated or available appropriations, plus any funds from previous years available for award in FY2009. Appendix A to this General Section lists the programs HUD expects to issue NOFAs for in FY2009.

Additional program NOFAs may be published during FY2009. Any additional funding opportunities will be made available on <http://www.Grants.gov> and the **Federal Register**.

III. Eligibility Information

A. *Eligible Applicants.* The individual program NOFAs describe the eligible applicants and eligible activities for each program. Applicants should be aware that HUD does not directly fund individuals through its competitive NOFA process.

B. *Cost Sharing or Matching.* The program NOFAs describe the applicable cost sharing, matching requirements, or leveraging requirements related to each program, if any. Although matching or cost sharing may not be required, HUD programs often encourage applicants to leverage grant funds with other funding to receive higher rating points.

It is important to note that the following Office of Management and Budget (OMB) circulars are applicable, and particular attention should be given to the provisions concerning the use of federal funds for matching requirements.

OMB Circular A-102 (Grants and Cooperative Agreements with State and Local Governments) establishes consistency and uniformity among federal agencies in the management of grants and cooperative agreements with state, local, and federally recognized Indian tribal governments. The circular

provides that state and local administration of federal funds must include fiscal and administrative requirements that are sufficiently specific to ensure that funds are used in compliance with all applicable federal statutory and regulatory provisions, costs are reasonable and necessary for operating these programs, and funds are not to be used for general expenses required to carry out other responsibilities of a state or its subrecipients. HUD's implementation of OMB Circular A-102 is found at 24 CFR part 85.

OMB Circular A-110 (Uniform Administrative Requirements for Grants and Agreements with Institutions of Higher Education, Hospitals, and Other Non-Profit Organizations) sets forth standards for obtaining consistency and uniformity among federal agencies in the administration of grants and agreements with institutions of higher education, hospitals, and other nonprofit organizations. This circular specifies the conditions for which funds may be used for cost sharing or matching and provides that federal funds shall not be accepted as cost sharing or matching, except where authorized by federal statute to be used for cost sharing or matching. HUD's implementation of OMB Circular A-110 is found at 24 CFR part 84.

OMB Circular A-87 (2 CFR Part 225) (Cost Principles for State, Local, and Indian Tribal Governments) establishes principles and standards for determining costs for federal awards carried out through grants, cost reimbursement contracts, and other agreements with state and local governments and federally recognized Indian tribal governments (governmental units). This circular provides that an allowable cost under a federal award does not include a cost sharing or matching requirement of any other federal award in the applicable funding period, except as specifically provided by federal law or regulation.

OMB Circular A-122 (2 CFR 230) (Cost Principles for Non-Profit Organizations) establishes principles for determining costs of grants, contracts, and other agreements with nonprofit organizations. This circular provides, similar to OMB Circular A-87, that an allowable cost under a federal award in the applicable funding period does not include a cost sharing or matching requirement of any other federally financed program.

Note: Applicants for funding under HUD's FY2009 NOFA are reminded of the importance of confirming that any federal grant funds that they intend to use as a cost sharing or matching share are available to be

used as matching funds under applicable statutes and regulations.

C. Other Requirements and Procedures Applicable to All Programs. Except as may be modified in the individual program NOFAs, the requirements, procedures, and principles listed below apply to all HUD programs in FY2009 for which funding is announced by NOFA and published in the **Federal Register**. Please read the individual program NOFAs for additional requirements and information.

1. *Statutory and Regulatory Requirements.* To be eligible for funding under HUD NOFAs issued during FY2009, applicants must meet all statutory and regulatory requirements applicable to the program or programs for which they seek funding. Applicants requiring program regulations may obtain them from the NOFA Information Center or through HUD's grants Web site at <http://www.hud.gov/offices/adm/grants/fundsavail.cfm>. See the individual program NOFAs for instructions on how HUD will respond to proposed activities that are ineligible.

2. *Threshold Requirements.*

a. *Ineligible Applicants.* HUD will not consider an application from an ineligible applicant.

b. *Dun and Bradstreet Data Universal Numbering System (DUNS) Number Requirement.* All applicants seeking funding directly from HUD must obtain a DUNS number and include the number in their Application for Federal Assistance submission. Failure to provide a DUNS number will prevent an applicant from obtaining an award, regardless of whether it is a new award or renewal of an existing one. This policy is pursuant to the OMB policy issued in the **Federal Register** on June 27, 2003 (68 FR 38402). HUD published its regulation implementing the DUNS number requirement on November 9, 2004 (69 FR 65024). A copy of the OMB **Federal Register** notice and HUD's regulation implementing the DUNS number can be found on HUD's Web site at <http://www.hud.gov/offices/adm/grants/duns.cfm>. When registering with Dun and Bradstreet, please be sure to use the organization's legal name that is used when filing a return with or making payments to the Internal Revenue Service. Organizations should also provide the zip code using the zip code plus the four additional digits. The DUNS number used in the application must be for the applicant organization, not the entity submitting the application on behalf of the applicant.

c. *Compliance with Fair Housing and Civil Rights Laws.*

(1) With the exception of federally recognized Indian tribes and their instrumentalities, applicants must comply with all applicable fair housing and civil rights requirements in 24 CFR 5.105(a). If you are a federally recognized Indian tribe, you must comply with the nondiscrimination provisions enumerated at 24 CFR 1000.12, as applicable. In addition to these requirements, there may be program-specific threshold requirements identified in the individual program NOFAs.

(2) If you, the applicant:

(a) Have been charged with an ongoing systemic violation of the Fair Housing Act; or
 (b) Are a defendant in a Fair Housing Act lawsuit filed by the Department of Justice alleging an ongoing pattern or practice of discrimination; or
 (c) Have received a letter of findings identifying ongoing systemic noncompliance under Title VI of the Civil Rights Act of 1964, section 504 of the Rehabilitation Act of 1973, or section 109 of the Housing and Community Development Act of 1974, and the charge, lawsuit, or letter of findings referenced in subparagraphs (a), (b), or (c) above has not been resolved to HUD's satisfaction before the application deadline, then you are ineligible and HUD will not rate and rank your application. HUD will determine if actions to resolve the charge, lawsuit, or letter of findings taken before the application deadline are sufficient to resolve the matter.

Examples of actions that would normally be considered sufficient to resolve the matter include, but are not limited to:

(i) A voluntary compliance agreement signed by all parties in response to a letter of findings;

(ii) A HUD-approved conciliation agreement signed by all parties;

(iii) A consent order or consent decree; or

(iv) An issuance of a final judicial ruling or a HUD Administrative Law Judge's decision.

d. *Conducting Business in Accordance with Core Values and Ethical Standards/Code of Conduct.* Applicants subject to 24 CFR parts 84 or 85 (most nonprofit organizations and state, local, and Indian tribal governments or government agencies or instrumentalities that receive federal awards of financial assistance) are required to develop and maintain a written code of conduct (see 24 CFR 84.42 and 85.36(b)(3)). Consistent with regulations governing specific programs, your code of conduct must prohibit real and apparent conflicts of interest that

may arise among officers, employees, or agents; prohibit the solicitation and acceptance of gifts or gratuities by your officers, employees, or agents for their personal benefit in excess of minimal value; and outline administrative and disciplinary actions available to remedy violations of such standards. Before entering into an agreement with HUD, an applicant awarded assistance under a HUD program NOFA announced in FY2009 will be required to submit a copy of its code of conduct and describe the methods it will use to ensure that all officers, employees, and agents of its organization are aware of its code of conduct. An applicant is prohibited from receiving an award of funds from HUD if it fails to meet this requirement for a code of conduct. An applicant that previously submitted an application and included a copy of its code of conduct will not be required to submit another copy if the applicant is listed on HUD's Web site <http://www.hud.gov/offices/adm/grants/codeofconduct/cconduct.cfm>, and if the information has not been revised. An applicant not listed on the Web site must submit a copy of its code of conduct with its FY2009 application for assistance. An applicant must also include a copy of its code of conduct if the information listed on the above Web site has changed (e.g., the person who submitted the previous application is no longer the authorized organization representative, the organization has changed its legal name or merged with another organization, or the address of the organization has changed, etc.). Any applicant that needs to may submit its code of conduct to HUD via facsimile using the form HUD-96011, "Facsimile Transmittal" ("Third Party Documentation Facsimile Transmittal" on Grants.gov) at the time of application submission. This form is available as part of your application package that was downloaded from Grants.gov. When using the facsimile transmittal form, please type the requested information. Use the form HUD-96011 as the cover page for the submission and include the following header in the top line of the form under *Name of Document Being Requested*: "Code of Conduct for (insert your organization's name, city, and state)." Fax the information to HUD's toll-free number at 800-HUD-1010. If you cannot access the 800 number or have problems, you may use 215-825-8798 (this is not a toll-free number). These are new numbers for FY2009 applications. These facsimile numbers are not those used for FY2008. If you use the wrong fax number, your fax will be entered as part of HUD's FY2008 database. HUD

cannot search its FY2008 database to match FY2009 faxes to FY2009 applications. As a result, your application will be reviewed without faxed information if you fail to use the FY2009 fax numbers.

Continuum of Care applicants should follow the directions in the Continuum of Care program NOFA for submission of Codes of Conduct.

e. *Delinquent Federal Debts*. It is HUD policy, consistent with the purposes and intent of 31 U.S.C. 3720B and 28 U.S.C. 3201(e), that applicants with an outstanding federal debt will not be eligible to receive an award of funds from the Department unless: (1) A negotiated repayment schedule is established and the repayment schedule is not delinquent, or (2) other arrangements satisfactory to HUD are made prior to the award of funds by HUD. If arrangements satisfactory to HUD cannot be completed within 90 days of notification of selection, HUD will not make an award of funds to the applicant, but offer the award to the next eligible applicant. Applicants selected for funding, or awarded funds, must report to HUD changes in status of current agreements covering federal debt. HUD may withhold funding, terminate an award, or seek other remedies from a grantee if a previously agreed-upon payment schedule has not been adhered to or a new agreement with the federal agency to which the debt is owed has not been signed.

f. *Pre-Award Accounting System Surveys*. HUD may arrange for a pre-award survey of the applicant's financial management system if the recommended applicant has no prior federal support, if HUD's program officials have reason to question whether the applicant's financial management system meets federal financial management standards, or if the applicant is considered a high risk based upon past performance or financial management findings. HUD will not disburse funds to any applicant that does not have a financial management system that meets federal standards. (Please see 24 CFR 84.21 if you are an institution of higher education, hospital, or other nonprofit organization. See 24 CFR 85.20 if you are a state, local government, or federally recognized Indian tribe).

g. *Name Check Review*. Applicants are subject to a name check review process. Name checks are intended to reveal matters that significantly reflect on the applicant's management and financial integrity, including if any key individual has been convicted or is presently facing criminal charges. If the name check reveals significant adverse

findings that reflect on the business integrity or responsibility of the applicant or any key individual, HUD reserves the right to: (1) Deny funding, or in the case of a renewal or continuing award, consider suspension or termination of an award immediately for cause, (2) require the removal of any key individual from association with management or implementation of the award, and (3) make appropriate provisions or revisions with respect to the method of payment or financial reporting requirements.

h. *False Statements*. A false statement in an application is grounds for denial or termination of an award and possible punishment, as provided in 18 U.S.C. 1001.

i. *Prohibition Against Lobbying Activities*. Applicants are subject to the provisions of Section 319 of Public Law 101-121 (approved October 23, 1989) (31 U.S.C. 1352) (the Byrd Amendment), which prohibits recipients of federal contracts, grants, or loans from using appropriated funds for lobbying the executive or legislative branches of the federal government in connection with a specific contract, grant, or loan. In addition, applicants must disclose, using Standard Form LLL (SF-LLL), "Disclosure of Lobbying Activities," any funds, other than federally appropriated funds, that will be or have been used to influence federal employees, members of Congress, or congressional staff regarding specific grants or contracts. Federally recognized Indian tribes and tribally designated housing entities (TDHEs) established by federally recognized Indian tribes as a result of the exercise of the tribe's sovereign power are excluded from coverage of the Byrd Amendment, but state-recognized Indian tribes and TDHEs established only under state law must comply with this requirement. Applicants must submit the SF-LLL if they have used or intend to use federal funds for lobbying activities.

j. *Debarment and Suspension*. In accordance with 2 CFR part 2424, no award of federal funds may be made to applicants that are presently debarred or suspended, or proposed to be debarred or suspended from doing business with the federal government.

3. *Other Threshold Requirements*. The individual program NOFAs for which you are applying may specify other threshold requirements. Additional threshold requirements may be identified in the discussion of "eligibility" requirements in the individual program NOFAs. If a program NOFA requires a certification of consistency with the Consolidated Plan and the applicant fails to provide

a certification, and such failure is not cured as a technical deficiency, HUD will not fund the application. If HUD is provided a signed certification indicating consistency with the area's approved Consolidated Plan and HUD finds that the activities are not consistent with the Consolidated Plan, HUD will not fund the inconsistent activities or will deny funding the application if a majority of the activities are not consistent with the approved Consolidated Plan. The determination not to fund an activity or to deny funding may be determined by a number of factors, including the number of activities being proposed, the impact of the elimination of the activities on the proposal, or the percent of the budget allocated to the proposed activities.

4. *Additional Nondiscrimination and Other Requirements.* Applicants and their subrecipients must comply with:

a. *Civil Rights Laws*, including the Americans with Disabilities Act of 1990 (42 U.S.C. 12101 *et seq.*), the Age Discrimination Act of 1974 (42 U.S.C. 6101 *et seq.*), and Title IX of the Education Amendments Act of 1972 (20 U.S.C. 1681 *et seq.*).

b. *Affirmatively Furthering Fair Housing.* Under section 808(e)(5) of the Fair Housing Act, HUD has a statutory duty to affirmatively further fair housing. HUD requires the same of its funding recipients. If you are a successful applicant, you will have a duty to affirmatively further fair housing opportunities for classes protected under the Fair Housing Act. Protected classes include race, color, national origin, religion, sex, disability, and familial status. Unless otherwise instructed in the individual program NOFA, your application must include specific steps to:

(1) Overcome the effects of impediments to fair housing choice that were identified in the jurisdiction's Analysis of Impediments (AI) to Fair Housing Choice (See Certification requirements under 24 CFR 91.225);

(2) Remedy discrimination in housing; and

(3) Promote fair housing rights and fair housing choice.

Further, you, the applicant, have a duty to carry out the specific activities provided in your responses to the individual program NOFA rating factors that address affirmatively furthering fair housing. These requirements apply to all HUD programs announced via a NOFA, unless specifically excluded in the individual program NOFA.

c. *Economic Opportunities for Low- and Very Low-Income Persons (Section 3).* Certain programs to be issued during

FY2009 require recipients of assistance to comply with section 3 of the Housing and Urban Development Act of 1968 (Section 3), 12 U.S.C. 1701u (Economic Opportunities for Low- and Very Low-Income Persons in Connection with Assisted Projects), and the HUD regulations at 24 CFR part 135. Review the individual program NOFAs to determine if section 3 applies to the program for which you are seeking funding. Section 3 requires recipients to ensure, to the greatest extent feasible, that training, employment, and other economic opportunities will be directed to low- and very-low income persons, particularly those who are recipients of government assistance for housing, and to business concerns that provide economic opportunities to low- and very low-income persons in the area in which the project is located. The section 3 regulations at 24 CFR part 135, subpart E, impose certain reporting requirements on recipients, including the submission of an annual report, using form HUD-60002 or HUD's online system at <http://www.hud.gov/offices/fheo/section3/section3.cfm>. Grantees reporting Section 3 activities in paper format should mail the report to: U.S. Department of Housing and Urban Development, Office of Fair Housing and Equal Opportunity, Economic Development Opportunity Division, 451 7th Street, SW., Room 5232, Washington, DC 20410.

The annual report is highly important to the Department in determining compliance with Section 3. Applicants are placed on notice that they are required to annually report section 3 data, as applicable. Failure to meet reporting requirements can result in sanctions such as debarment, suspension, or denial of participation in HUD programs (24 CFR 135.76(g)).

d. *Ensuring the Participation of Small Businesses, Small Disadvantaged Businesses, and Women-Owned Businesses.* HUD is committed to ensuring that small businesses, small disadvantaged businesses, and women-owned businesses participate fully in HUD's direct contracting and in contracting opportunities generated by HUD financial assistance. Too often, these businesses still experience difficulty accessing information and successfully bidding on federal contracts. State, local, and Indian tribal governments are required by 24 CFR 85.36(e) and nonprofit recipients of assistance (grantees and subgrantees) by 24 CFR 84.44(b) to take all necessary affirmative steps in contracting for the purchase of goods or services to assure that minority firms, women-owned business enterprises, and labor surplus

area firms are used whenever possible or as specified in the individual program NOFAs.

e. *Real Property Acquisition and Relocation.* Except as otherwise provided by federal statute, HUD-assisted programs or projects are subject to the Uniform Relocation Assistance and Real Property Acquisition Policies Act of 1970, as amended (Uniform Act or URA) (42 U.S.C. 4601), and the governmentwide implementing regulations issued by the U.S. Department of Transportation at 49 CFR part 24. The Uniform Act's protections and assistance apply to acquisitions of real property and displacements resulting from the acquisition, rehabilitation, or demolition of real property for federal or federally assisted programs or projects. With certain limited exceptions, real property acquisitions for a HUD-assisted program or project must comply with 49 CFR part 24, subpart B. To be exempt from the URA's acquisition policies, real property acquisitions conducted without the threat or use of eminent domain, commonly referred to as "voluntary acquisitions," must satisfy the applicable requirements of 49 CFR 24.101(b)(1) through (5). Evidence of compliance with these requirements must be maintained by the recipient. The URA's relocation requirements remain applicable to any tenant who is displaced by an acquisition that meets the requirements of 49 CFR 24.101(b)(1) through (5).

The relocation requirements of the Uniform Act, and its implementing regulations at 49 CFR part 24, cover any person who moves permanently from real property or moves personal property from real property as a direct result of acquisition, rehabilitation, or demolition for a program or project receiving HUD assistance. While there are no statutory provisions for "temporary relocation" under the URA, the URA regulations recognize that there are circumstances where a person will not be permanently displaced but may need to be moved from a project for a short period of time. Appendix A of the URA regulation (49 CFR 24.2(a)(9)(ii)(D)) explains that any tenant who has been temporarily relocated for a period beyond one year must be contacted by the displacing agency and offered URA relocation assistance. Some HUD program regulations provide additional protections for temporarily relocated tenants. For example, 24 CFR 583.310(f)(1) provides guidance on temporary relocation for the Supportive Housing Program for the homeless. Before planning their project, applicants

should review the regulations for the programs for which they are applying. Generally, the URA does not apply to displacements resulting from the demolition or disposition of public housing covered by section 18 of the United States Housing Act of 1937.

Additional information and resources pertaining to real property acquisition and relocation for HUD-funded programs and projects are available on HUD's Real Estate Acquisition and Relocation Web site at <http://www.hud.gov/relocation>. The Web site contains applicable laws and regulations, policy and guidance, publications, training resources, and a listing of HUD contacts to answer questions or otherwise provide assistance.

f. *Executive Order 13166, "Improving Access to Services for Persons with Limited English Proficiency (LEP)."* Executive Order 13166 seeks to improve access to federally assisted programs and activities for individuals who, as a result of national origin, are limited in their English proficiency. Applicants obtaining federal financial assistance from HUD shall take reasonable steps to ensure meaningful access to their programs and activities to LEP individuals. As an aid to recipients, HUD published *Final Guidance to Federal Financial Assistance Recipients Regarding Title VI Prohibition Against National Origin Discrimination Affecting Limited English Proficient Persons (LEP Guidance)* in the **Federal Register** on January 22, 2007 (72 FR 2732). For assistance and information regarding LEP obligations, go to <http://www.hud.gov/offices/fheo/promotingfh/lep.cfm>. A link to the LEP Guidance can be found on that page.

g. *Executive Order 13279, "Equal Protection of the Laws for Faith-Based and Community Organizations."* HUD is committed to full implementation of Executive Order 13279. The Executive Order established fundamental principles and policymaking criteria to guide federal agencies in formulating and developing policies that have implications for faith-based and community organizations, to ensure the equal protection for these organizations in social service programs receiving federal financial assistance. Consistent with this order, HUD has reviewed all Departmental policies and regulations that have implications for faith-based and community organizations and has established a policy priority to provide full and equal access to grassroots faith-based and other community organizations in HUD program implementation. HUD revised its program regulations in 2003 and 2004 to

remove the barriers to participation by faith-based organizations in HUD funding programs (68 FR 56396, September 30, 2003; 69 FR 41712, July 9, 2004; and 69 FR 62164, October 22, 2004). Copies of the regulatory changes can be found at <http://www.hud.gov/offices/adm/grants/fundsavail.cfm>.

h. *Accessible Technology.* Section 508 of the Rehabilitation Act (Section 508) requires HUD and other federal departments and agencies to ensure, when developing, procuring, maintaining, or using electronic and information technology (EIT), that the EIT allow, regardless of the type of medium, persons with disabilities to access and use information and data on a comparable basis as is made available to and used by persons without disabilities. Section 508's coverage includes, but is not limited to, computers (hardware, software, word processing, e-mail, and Internet sites), facsimile machines, copiers, and telephones. Among other things, Section 508 requires that, unless an undue burden would result to the federal department or agency, EIT must allow individuals with disabilities who are federal employees or members of the public seeking information or services to have access to and use of information and data on a comparable basis as that made available to employees and members of the public who are not disabled. Where an undue burden exists to the federal department or agency, alternative means may be used to allow a disabled individual use of the information and data. Section 508 does not require that information services be provided at any location other than a location at which the information services are generally provided. HUD encourages its funding recipients to adopt the goals and objectives of Section 508 by ensuring, whenever EIT is used, procured, or developed, that persons with disabilities have access to and use of the information and data made available through the EIT on a basis comparable as is made available to and used by persons without disabilities. This does not affect recipients' required compliance with section 504 of the Rehabilitation Act and, where applicable, the Americans with Disabilities Act. Applicants and recipients seeking further information on accessible technology should go to <http://www.section508.gov/>.

i. *Procurement of Recovered Materials.* State agencies and agencies of a political subdivision of a state that are using assistance under a HUD program NOFA for procurement, and any person contracting with such an agency with respect to work performed under an

assisted contract, must comply with the requirements of section 6002 of the Solid Waste Disposal Act, as amended by the Resource Conservation and Recovery Act.

In accordance with section 6002, these agencies and persons must procure items designated in guidelines of the Environmental Protection Agency (EPA) at 40 CFR part 247 that contain the highest percentage of recovered materials practicable, consistent with maintaining a satisfactory level of competition, where the purchase price of the item exceeds \$10,000 or the value of the quantity acquired in the preceding fiscal year exceeded \$10,000; must procure solid waste management services in a manner that maximizes energy and resource recovery; and must have established an affirmative procurement program for procurement of recovered materials identified in the EPA guidelines.

j. *Participation in HUD-Sponsored Program Evaluation.* As a condition of the receipt of financial assistance under a HUD program NOFA, all successful applicants will be required to cooperate with all HUD staff or contractors who perform HUD-funded research or evaluation studies.

k. *Executive Order 13202, "Preservation of Open Competition and Government Neutrality Towards Government Contractors' Labor Relations on Federal and Federally Funded Construction Projects."* Compliance with HUD regulations at 24 CFR 5.108 that implement Executive Order 13202 is a condition of receipt of assistance under a HUD program NOFA.

l. *Salary Limitation for Consultants.* FY2009 funds may not be used to pay or to provide reimbursement for payment of the salary of a consultant at a rate more than the equivalent of General Schedule 15, Step 10.

m. *OMB Circulars and Governmentwide Regulations Applicable to Financial Assistance Programs.* Certain OMB Circulars (2 CFR 225) also apply to HUD program NOFAs. The policies, guidance, and requirements of OMB Circulars A-87 (Cost Principles Applicable to Grants, Contracts and Other Agreements With State and Local Governments), A-21 (Cost Principles for Education Institutions), A-122 (Cost Principles for Non-Profit Organizations), A-133 (Audits of States, Local Governments, and Non-Profit Organizations), and the regulations at 24 CFR part 84 (Grants and Agreements With Institutions of Higher Education, Hospitals, and Other Non-Profit Organizations), and 24 CFR part 85 (Administrative Requirements for Grants and Cooperative Agreements

to State, Local, and Federally Recognized Indian Tribal Governments) may apply to the award, acceptance, and use of assistance under the individual program NOFAs, and to the remedies for noncompliance, except when inconsistent with the provisions of HUD's Appropriations Act for FY2009, other federal statutes or regulations, or the provisions of this notice. Compliance with additional OMB circulars or governmentwide regulations may be specified for a particular program in the Program Section NOFA. Copies of the OMB circulars may be obtained from <http://www.whitehouse.gov/omb/circulars/index.html>, or the Executive Office of the President Publications, New Executive Office Building, Room 2200, Washington, DC 20503; telephone number 202-395-3080 (this is not a toll-free number). Individuals with speech or hearing impairments may access this number by dialing 800-877-8339 (toll-free TTY Federal Information Relay Service).

n. *Environmental Requirements.* If you become a recipient under a HUD program that assists in physical development activities or property acquisition, you are generally prohibited from acquiring, rehabilitating, converting, demolishing, leasing, repairing, or constructing property, or committing or expending HUD or non-HUD funds for these types of program activities, until one of the following has occurred:

(1) HUD has completed an environmental review in accordance with 24 CFR part 50; or

(2) For programs subject to 24 CFR part 58, HUD has approved a recipient's Request for Release of Funds (form HUD-7015.15) following a responsible entity's completion of an environmental review.

You, the applicant, should consult the individual program NOFA for any program for which you are interested in applying to determine the procedures for, timing of, and any modifications or exclusions from environmental review under a particular program.

o. *Conflicts of Interest.* If you are a consultant or expert who is assisting HUD in rating and ranking applicants for funding under HUD NOFAs published in FY2009, you are subject to 18 U.S.C. 208, the federal criminal conflict-of-interest statute, and the Standards of Ethical Conduct for Employees of the Executive Branch regulation published at 5 CFR part 2635. As a result, if you have assisted or plan to assist applicants with preparing applications for NOFAs published in FY2009, you may not serve on a

selection panel and you may not serve as a technical advisor to HUD. Persons involved in rating and ranking HUD FY2009 NOFAs, including experts and consultants, must avoid conflicts of interest or the appearance of such conflicts. Persons involved in rating and ranking applications must disclose to HUD's General Counsel or HUD's Ethics Law Division the following information, if applicable, how the selection or non-selection of any applicant under FY2009 NOFAs will affect the individual's financial interests, as provided in 18 U.S.C. 208, or how the application process involves a party with whom the individual has a covered relationship under 5 CFR 2635.502. The person must disclose this information before participating in any matter regarding an FY2009 NOFA. If you have questions regarding these provisions or concerning a conflict of interest, you may call the Office of General Counsel, Ethics Law Division, at 202-708-3815 (this is not a toll-free number).

p. *Drug-Free Workplace.* Applicants awarded funds from HUD are required to provide a drug-free workplace. Compliance with this requirement means that the applicant will:

(1) Publish a statement notifying employees that it is unlawful to manufacture, distribute, dispense, possess, or use a controlled substance in the applicant's workplace and that such activities are prohibited. The statement must specify the actions that will be taken against employees for violation of this prohibition. The statement must also notify employees that, as a condition of employment under the federal award, they are required to abide by the terms of the statement and that each employee must agree to notify the employer in writing of any violation of a criminal drug statute occurring in the workplace no later than 5 calendar days after such violation;

(2) Establish an ongoing drug-free awareness program to inform employees about:

(a) The dangers of drug abuse in the workplace;

(b) The applicant's policy of maintaining a drug-free workplace;

(c) Any available drug counseling, rehabilitation, or employee maintenance programs; and

(d) The penalties that may be imposed upon employees for drug abuse violations occurring in the workplace;

(3) Notify the federal agency in writing within 10 calendar days after receiving notice from an employee of a drug abuse conviction or otherwise receiving actual notice of a drug abuse conviction. The notification must be provided in writing to HUD's Office of

Departmental Grants Management and Oversight, Department of Housing and Urban Development, 451 7th Street, SW., Room 3156, Washington DC 20410-3000, along with the following information:

(a) The program title and award number for each HUD award covered;

(b) The HUD staff contact name, telephone, and fax numbers;

(c) A grantee contact name, telephone, and fax numbers; and

(4) Require that each employee engaged in the performance of the federally funded award be given a copy of the drug-free workplace statement required in item (1) above and notify the employee that one of the following actions will be taken against the employee within 30 calendar days of receiving notice of any drug abuse conviction:

(a) Institution of a personnel action against the employee, up to and including termination consistent with requirements of the Rehabilitation Act of 1973, as amended; or

(b) Imposition of a requirement that the employee participate satisfactorily in a drug abuse assistance or rehabilitation program approved for such purposes by a federal, state, or local health, law enforcement, or other appropriate agency.

q. *Safeguarding Resident/Client Files.* In maintaining resident and client files, HUD funding recipients shall observe state and local laws concerning the disclosure of records that pertain to individuals. Further, recipients are required to adopt and take reasonable measures to ensure that resident and client files are safeguarded. This includes when reviewing, printing, or copying client files.

r. *Compliance with the Federal Funding Accountability and Transparency Act of 2006 (Pub. L. 109-282) (Transparency Act).* Applicants receiving an award from HUD should be aware of the requirements of the Transparency Act. The Transparency Act requires the establishment of a central Web site that makes information available to the public regarding entities receiving federal financial assistance, by not later than January 1, 2008. In fulfillment of the requirements of the Act, OMB launched <http://www.USAspending.gov> in December 2007. The Web site makes information available to the public on the direct awards made by the federal government. The Transparency Act also requires, beginning not later than January 2009, that data on subawards be made available on the same Web site. In anticipation of the implementation of this requirement, HUD is placing

awardees of its FY2009 competitive funding on notice of these requirements and note that once implemented, grantees will be required to report their subaward data to HUD or a central federal database. The only exceptions to this requirement under the

Transparency Act are: (1) Federal transactions below \$25,000, (2) credit card transactions prior to October 1, 2008, (3) awards to entities that demonstrate to the Director of OMB that the gross income of such entity from all sources did not exceed \$300,000 in the previous tax year of such entity, and (4) awards to individuals. Guidance for receiving an exception under item (3) above has not been finalized by OMB.

HUD is responsible for placing award information for direct grantees on the government Web site. The reporting of subaward data is the responsibility of the grantee. Grantees should be aware that the law requires the information provided on the federal Web site to include the following elements related to all subaward transactions, except as noted above:

(a) The name of the entity receiving the award;

(b) The amount of the award;

(c) Information on the award including the transaction type, funding agency, the North American Industry Classification System (NAICS) code or Catalog of Federal Domestic Assistance (CFDA) number (where applicable), program source, and an award title descriptive of the purpose of each funding action;

(d) The location of the entity receiving the award and primary location of performance under the award, including the city, state, congressional district, and country;

(e) A unique identifier of the entity receiving the award and of the parent entity of the recipient (the DUNS number), should the entity be owned by another entity; and

(f) Any other relevant information specified by OMB.

HUD expects OMB to issue further guidance on subaward reporting in late 2008 or early 2009. Based on preliminary input from the various federal agencies, applicants should be aware that consideration is being given to requiring the disclosure of additional data elements to help track the flow of funding from the original federal award. Such data elements under consideration include the tier at which the subaward was made, the federal award number issued to the direct awardee, the dollar amount of the federal award emanating from the direct award going to the subawardee, as well as the total subaward amount, which could include

funds from other sources. Additional information regarding these requirements will be issued by OMB and will be provided when available.

IV. Application and Submission Information

A. Addresses To Request Application Package

This section describes how applicants may obtain application forms and request technical assistance.

1. Technical Assistance and Resources for Grants.gov Electronic Grant Applications.

a. *Grants.gov Customer Support.* Grants.gov provides customer support information on its Web site at <http://www.grants.gov/contactus/contactus.jsp>. Applicants having difficulty accessing the application and instructions or having technical problems can receive customer support from Grants.gov by calling 800-518-GRANTS (this is a toll-free number) or by sending an e-mail to support@grants.gov. The customer support center is open from 7 a.m. to 9 p.m. eastern time, Monday through Friday, except federal holidays. The customer service representatives will assist applicants in accessing the information and addressing technology issues, including accessibility problems, in accordance with section 508 of the Rehabilitation Act (See paragraph 4(h), Accessible Technology). Applicants should ask for a Grants.gov call center ticket number if not provided one by the call center customer service representative. In case of issues, HUD relies on the call center ticket logs as part of the review of records.

b. *HUD Web site.* The following documents and information can be found on HUD's Web site at <http://www.hud.gov/offices/adm/grants/fundsavail.cfm>.

(1) *Desktop Users Guide for Submitting Electronic Grant Applications.* HUD will publish on its Web site at <http://www.hud.gov/offices/adm/grants/fundsavail.cfm> an update to its detailed Desktop Users Guide that walks applicants through the electronic process, beginning with finding a funding opportunity, completing the registration process, and downloading and submitting the electronic application. The guide will include helpful step-by-step instructions, screen shots, and tips to assist applicants in becoming familiar with submitting applications electronically and overcoming submission issues, based upon past lessons learned from working with applicants and the Grants.gov Project Management Office (PMO).

(2) *Connecting with Communities: A User's Guide to HUD Programs and the FY2009 NOFA Process Guidebook.* This guidebook to HUD programs will be available from the HUD NOFA Information Center and at HUD's Funds Available Web site at <http://www.hud.gov/offices/adm/grants/fundsavail.cfm> after the publication of the General Section and when appropriations have been enacted for FY2009. The guidebook provides a brief description of all HUD programs that have funding available in FY2009, identifies eligible applicants for the programs and the program office responsible for the administration of the program.

(3) *NOFA Webcasts.* HUD provides technical assistance and training on its programs announced through its NOFAs. The NOFA broadcasts are interactive and allow potential applicants to obtain a better understanding of the threshold, program, and application submission requirements for funding. Participation in this training opportunity is free of charge and can be accessed via HUD's Web site. The NOFA webcast schedule can be found via HUD's Web site at <http://www.hud.gov/webcasts/index.cfm>.

c. *HUD's NOFA Information Center.* Applicants that do not have Internet access and need to obtain a copy of a NOFA can contact HUD's NOFA Information Center, toll free, at 800-HUD-8929. Persons with hearing or speech impairments may access this number, toll free, via TTY by calling the Federal Information Relay Service at 800-877-8339. The NOFA Information Center is open between the hours of 10 a.m. and 6:30 p.m. eastern time, Monday through Friday, except federal holidays.

d. *HUD Staff.* HUD staff will be available to provide you with general guidance and technical assistance about this notice or about individual program NOFAs. However, HUD staff is not permitted to help prepare your application. Following selection of applicants, but before announcement of awards, HUD staff is available to assist in clarifying or confirming information that is a prerequisite to the offer of an award or annual contributions contract (ACC) by HUD. If you have program-related questions, follow the instructions in section VII of the Program Section entitled "Agency Contact(s)" in the program NOFA under which you are applying. If you have difficulty in submitting your application, please first contact the Grants.gov Help Desk. The Grants.gov Help Desk can be reached by calling

800-518-GRANTS or e-mailing Support@Grants.gov. HUD recommends calling the Help Desk rather than e-mailing, because determining the basis for the problem may take some conversation with the Grants.gov Support Customer Service Representative. Grants.gov can try to assist you in overcoming technology obstacles, but can only provide assistance with 24 to 48 hours advance notice so it has resources and time to diagnose the problems. Applicants are reminded to retain any Grants.gov Help Desk ticket number(s).

B. Content and Form of Application Submission

1. *Use of Adobe Forms Application Packages.* In FY2009, HUD is again using Adobe Forms in the application packages available from Grants.gov. The Adobe Forms packages are compatible with the Microsoft Windows Vista operating system, Apple Macintosh computers, and Microsoft Office 2007. For more information, see the Grants.gov Web site at http://www.grants.gov/assets/Vista_and_office_07_Compatibility.pdf. Applicants need to pay strict attention to the submission instructions provided in this notice to have a successful submission using the Adobe Forms packages.

2. *Instructions on How to Register for Electronic Application Submission.* Applicants must submit their applications electronically through Grants.gov. Before you can do so, you must complete several important steps to register as a submitter. The registration process can take approximately 2 to 4 weeks to complete. Therefore, registration should be done in sufficient time before you submit your application. To register, applicants must complete five sequential steps:

- a. *Step One:* Obtain a Dun and Bradstreet Data Universal Numbering System (DUNS);
- b. *Step Two:* Register with the CCR;
- c. *Step Three:* Register with the Credential Provider;
- d. *Step Four:* Register with Grants.gov; and
- e. *Step Five:* Granting Approval of an AOR to Submit an Application on Behalf of the Organization.

All five steps must be completed to have a valid registration and to be able to successfully submit an application via Grants.gov. Detailed explanation of each step and important information related to each step in the process is available in HUD's Early Registration notice, published December 5, 2008 (73 FR 74179). Detailed information is also described below.

3. Key Terms Used as Part of the Registration Process.

a. *Applicant Organization.* The applicant organization is an entity that is identified as the legal applicant for funding in box 8a on the SF-424, Application for Federal Assistance, and is the organization that HUD will hold accountable to fulfill the requirements of the award, should the applicant be selected for funding. Grant writers or persons authorized to submit an application for funding by the applicant organization eBusiness Point of Contact (see definition below) must not enter their organization or their organization's DUNS number in the SF-424, Application for Federal Assistance. Grant writers who wish to submit an application on behalf of an applicant organization must become an AOR to submit the application. (See definition of Authorized Organization Representative below, and registration instructions for AORs later in this notice).

b. *Authorized Organization Representative (AOR).* The applicant organization (applicant legal name on box 8a of the SF-424) E-Biz POC must grant permission for a person to become an AOR and submit an application on behalf of the applicant organization through the Grants.gov system. Authorizing an AOR safeguards the applicant organization from unauthorized individuals who may attempt to submit a grant application without permission. To check the AOR status, go to <https://apply07.grants.gov/apply/ApplicantLoginGetID>. Then, using the user name and password (obtained from the Credential Provider), check to see if the E-Biz POC has granted approval or if the request to be an AOR is noted as "Request Sent." If the information says "Request Sent," the approval has not been granted. AORs are advised to contact the E-Biz POC to determine the basis for the lack of approval. A proposed AOR cannot submit the application to Grants.gov without AOR status noted as "Approved."

c. *eBusiness Point of Contact (E-Biz POC).* The E-Biz POC is identified during the Central Contractor Registration Process (Step 2 of the Registration Process). The E-Biz POC must grant authority for a person to be the AOR. An E-Biz POC may serve as an AOR as well as an E-Biz POC. The E-Biz POC becomes the sole Grants.gov authority for the organization and has the capability of designating or revoking an AOR's ability to submit a grant application on behalf of the organization using the Grants.gov system.

d. *Marketing Partner ID Number (MPIN).* As part of the CCR Registration Process, the E-Biz POC will be asked to create an MPIN. The MPIN is a nine character (alpha numeric) password that is used to access other systems and should be well guarded. For organizations wishing to apply for federal grants using the Grants.gov system, the MPIN is required for the E-Biz POC to log into the Grants.gov system and grant the person requesting permission to be an AOR, the permission to submit the grant on behalf of the applicant organization.

e. *Trading Partner Identification Number (TPIN).* A TPIN is a password that is used to access the applicant organization's Central Contractor Registration (CCR) data. Organizations that become active in CCR are issued a TPIN (password) to access their record in order to make, or request, any changes or updates to their CCR registration. Because of the sensitivity of this data, CCR recommends that CCR registrants not disclose their TPIN to anyone under any circumstances.

4. Instructions on Completing the Registration Process for New Applicants or Applicants Updating or Renewing Registration.

a. The Need to Register with Grants.gov.

HUD provides funding to organizations only. This information, therefore, is directed to HUD applicants that are organizational entities.

Before an applicant can apply for a grant opportunity, the applicant must first register with Grants.gov to provide and obtain certain identifying information. Please note that registration is a multi-step process. The registration process also requires the applicant organization to provide information at Web sites other than Grants.gov. Registration protects both HUD and the applicant. Specifically, registration confirms that the applicant organization E-Biz POC has designated and authorized a certain individual or entity to submit an application on its behalf and assures HUD that it is interacting with a designated representative of the applicant who has been authorized to submit the application.

b. *Steps to Register.* HUD's NOFA process requires applicants to submit applications electronically through Grants.gov. Before being able to do so, applicants must complete several important steps to register or update/renew their registration to be able to submit the application. The registration process can take approximately 2 to 4 weeks to complete.

(1) *Step One: Obtain a Dun and Bradstreet Data Universal Numbering System (DUNS).* Step One of the registration process requires an applicant organization to obtain a DUNS number for the organizational entity for which an application for federal assistance will be submitted. All organizations seeking funding directly from HUD must have a DUNS number and include the number on the form SF-424, Application for Federal Assistance, which is part of the application package. The DUNS number is also required as part of the registration process. If the applicant organizational entity identified in box 8a on the SF-424 already has a DUNS number, it must use that number. The number must be registered with the legal name of the organizational entity. Failure to provide a DUNS number or the correct DUNS number associated to the applicant organization legal name as entered on the form SF-424, box 8a and CCR can prevent you from submitting a grant application or obtaining an award, regardless of whether it is a new award or renewal of an existing one. This policy is pursuant to OMB policy issued in the **Federal Register** on June 27, 2003 (68 FR 38402). HUD codified the DUNS number requirement on November 9, 2004 (69 FR 65024). A copy of the OMB **Federal Register** notice and HUD's regulation codifying the DUNS number requirement can be found at <http://www.hud.gov/offices/adm/grants/duns.cfm>. Applicants cannot submit an electronic application without a DUNS number. An incorrect DUNS number in an application package will result in Grants.gov rejecting the application, because the DUNS number entered in the application will not be consistent with the DUNS number associated to the applicant legal name as entered in box 8a of the form SF-424, CCR, and Internal Revenue Service (IRS) records. The applicant legal name and DUNS number used on the application must match the DUNS number and organization name used in the CCR. Applicants must note that information entered and used to obtain the DUNS number will be used to pre-populate the CCR, which is Step Two of the registration process. Applicants should, therefore, carefully review information entered when obtaining a DUNS number. When registering with Dun and Bradstreet (D&B), please be sure to use the organizational entity's legal name used when filing a return or making a payment to the Internal Revenue Service (IRS). Organizations should also provide the zip code using the zip code plus four code (Zip+4).

Applicants can obtain a DUNS number by calling 866-705-5711 option 4 for grant applicants. (This is a toll-free number.) Applicants in Alaska and Puerto Rico can call 800-234-3867. The approximate time to get a DUNS number is 10 to 15 minutes, and there is no charge. Applicants may also obtain a DUNS number by accessing the D&B Web site at <http://fedgov.dnb.com/webform>. The approximate time to create the number online is one business day. After obtaining a DUNS number, applicants should wait 24 to 48 hours to register with the CCR so that its DUNS number has time to become activated in the D&B records database.

(2) *Step Two: Register with the CCR.* The second step of the registration process is registering with the CCR. The CCR is the primary registrant database for the federal government. An organization planning to submit a grant application for the first time must register, using its legal business name and name used with the IRS. CCR allows you to establish roles and user names for representatives that will use Grants.gov to submit electronic grant applications. Applicant organizations must annually update or renew their registration at <http://www.ccr.gov>, by clicking on the link entitled "Update or Renew Registration." If you need assistance with the CCR registration process, you can contact the CCR Assistance Center, 24 hours a day, 7 days a week, at 888-277-2423 or 269-961-5757. Applicants can also obtain assistance online at <http://www.ccr.gov>. A CCR Handbook that guides applicants through the registration process is available on the CCR Web site by clicking on "Help." If an applicant organization fails to update/renew its CCR registration, the Grants.gov registration will lapse prohibiting the application from being accepted by Grants.gov due to failure to have a complete registration. Registration, including update/renewal, can take several weeks as CCR compares its records to those maintained by D&B and the IRS. The records of D&B, CCR, and the IRS must match. If discrepancies arise, Step Two cannot be completed until the discrepancies are resolved. For this reason, HUD urges applicants to complete the CCR registration, or update/renew its existing registration, immediately. Otherwise, the CCR check with D&B and IRS records may delay completing the registration process and adversely affect the ability to submit a grant application. The CCR registration process consists of completing a Trading Partner Profile (TPP), which contains general, corporate, and financial

information about your organization. When completing the TPP, you will be required to identify an E-Biz POC, responsible for maintaining the information in the TPP and granting authorization to individuals to serve as AORs. An AOR is the individual who will submit the application through Grants.gov for the applicant organization. Applicants can check the CCR registration and E-Biz POC by going to <http://www.ccr.gov> and search by clicking on "Search CCR."

(a) *CCR Use of D&B Information.* In July 2006, CCR implemented a policy change. Under this policy change, instead of obtaining name and address information directly from the registrant, CCR obtains the following data fields from D&B: Legal Business Name, Doing Business as Name (DBA), Physical Address, and Postal Code (Zip+4). Registrants will not be able to enter or modify these fields in CCR because they will be pre-populated using previously registered DUNS records data. During a new registration, or when updating a record, the registrant has a choice to accept or reject the information provided from the D&B records. If the registrant agrees with the D&B supplied information, the D&B data will be accepted into the CCR registrant record. If the registrant disagrees with the D&B supplied data, the registrant must go to the D&B Web site at <http://fedgov.dnb.com/webform> to modify the information contained in D&B's records before proceeding with its CCR registration. Once D&B confirms the updated information, the registrant must revisit the CCR Web site and "accept" D&B's changes. Only at this point will the D&B data be accepted into the CCR record. This process can take up to 2 business days for D&B to send modified data to CCR, and that timeframe may be longer if data is sent from abroad.

(b) *CCR EIN/TIN Validation.* To complete the CCR registration and qualify as a vendor eligible to bid for federal government contracts or apply for federal grants, the EIN/TIN and Employer/Taxpayer Name combination you provide in the IRS Consent Form must match exactly to the EIN/TIN and Employer/Taxpayer Name used in federal tax matters. It will take one to two business days to validate new and updated records prior to becoming active in CCR. Please be sure that the data items provided to D&B match information provided to the IRS. If the registration in D&B and the CCR do not match the IRS information, an error message will result. Until the discrepancies have been resolved, the registration will not be completed. HUD recommends that applicant

organizations carefully review their D&B and CCR registration information for accuracy immediately upon publication of this notice. If you have questions about your EIN/TIN, call 800-829-4933.

(c) *Detailed Steps for NEW applicant organizations to register with CCR.* The following is a step-by-step guide to help an applicant organization register with CCR. Additional assistance is available online at <http://www.ccr.gov>. Before beginning the CCR registration process, organizations should designate an individual who will be responsible for completing the CCR registration and managing the information entered into CCR. The listing below identifies the steps in the CCR registration process.

(i) Go to <http://www.ccr.gov/>. Once on the site, on the left side of the screen, click "Start a New Registration." At the "Start a New Registration" screen, of the three choices, please select "I am not a U.S. Federal Government entity." Click "Continue."

Note: CCR registration is NOT required for individuals; however, HUD does not directly fund individuals through its NOFA process.

(ii) The next screen provides review items that must be completed before continuing in CCR. After reviewing the information and all items have been completed, click "Continue with Registration."

(iii) To begin registration with CCR, enter the organization entity's DUNS number and click "Next."

(iv) At the next screen, "New Registration," enter the organization's DUNS number. Then click "Next." The next "New Registration" screen displays the DUNS number. The registrant will be prompted to enter the organization information, e.g., name, address, etc. If the information inputted does not match that contained in the D&B record for the DUNS number provided, the system will state: "Try again by correcting your input below" or "Contact D&B to make a change to your D&B DUNS record."

(v) The next page of "New Registration" is "Verify Your Results with D&B." Here the registrant will be asked, "Is this information correct?" After ensuring the accuracy of the information, click on "Accept/Continue or Cancel."

(vi) If you "Accept/Continue," the confirmation number will be displayed. This is a temporary number that allows the registrant to save the registration as a work in progress. Print this page. A temporary number along with the organization DUNS number will let the registrant access CCR to complete the registration at a later date.

(vii) Continuing registration from the Confirmation page, click "Continue."

(viii) "How to Complete your Registration" is the next page. Once the information has been reviewed and found correct, click "Continue."

(ix) The "General Information" page is the next screen. On this page the registrant will need to complete all the required information.

(x) Creating a Marketing Partner ID Number (MPIN). The final step in creating the organization's TPP requires the registrant to create an MPIN. The MPIN is a self-defined nine character password that the E-Biz POC will need to access Grants.gov to authorize an AOR to be able to submit a grant application.

(xi) *Registration Notification.* If the registration was submitted successfully, the registrant will receive two letters through the U.S. Mail or via email. The first welcomes the registrant to CCR and includes a copy of the registration. The second contains the confidential TPIN. Receipt of the TPIN confirms successful registration in CCR and serves as the registrant's confidential password to change CCR information.

(d) *Detailed Steps for Updating/Renewing Current Registrations.*

(i) The E-Biz POC for the organization that is identified in box 8a of the SF-424 should go to <http://www.ccr.gov/>. Once on the Web site, on the left side of the screen, click "Update or Renew Registration." At the "Update Renew or Registration" screen, of the three choices, please select "I am not a U.S. Federal Government entity." Click "Continue."

Note: CCR registration is NOT required for individuals. HUD does not directly fund individuals through its NOFA process.

(ii) The next screen asks the E-Biz POC to enter the organization's DUNS number and TPIN number sent to the E-Biz POC at the time of the last update. Click "Log In" to continue.

Note: If the E-Biz POC can't remember the TPIN, the site provides a link to request the TPIN.

(iii) The next screen, "General Information," displays the organization information. This site allows the E-Biz POC to update information contained in CCR. Once information has been reviewed and, as needed, updated, click on "Validate/Save Data."

Note: The E-Biz POC will validate and save data contained within CCR for Corporate Information, Goods/Services, Financial, Points of Contact, and IRS content. Once the information has been validated and saved in each required section, the last screen will indicate "Registration Complete."

(e) *Current Registrants without an MPIN.* If you currently have an active registration in CCR and you do not have

an MPIN, you will need to do the following:

(i) Access the CCR Web site at <http://www.ccr.gov>. At the left margin, click on "Update or Renew Registration."

(ii) Select "I am not a U.S. Federal Government entity." Click "Continue."

(iii) Enter the organization's DUNS number and TPIN.

(iv) On the next page, click on the link "Points of Contact." Complete all fields for the E-Biz POC and the alternate E-Biz POC. Scroll down to the bottom of the Points of Contact page, and create your own MPIN. Once completed, click on the "Validate/Save" button.

Note to Active Registrants in CCR: A TPIN is a password that is used to access your CCR data. Organizations that become active in CCR are issued a TPIN (password) to access and maintain their data. Because of the sensitivity of this data, CCR recommends that you do not disclose your TPIN to anyone under any circumstances.

(3) *Step Three: Register with the Credential Provider.*

(a) *Registering with Credential Provider.* To safeguard the security of electronic information, Grants.gov utilizes a Credential Provider to determine with a degree of assurance that someone is really who he or she claims to be. Once the organization requesting funding has identified who will be submitting the Application for Federal Assistance on their behalf, the person to submit the application must register with a Credential Provider to create his/her user name and password. The user name and password created through the credential provider will be registered with Grants.gov as part of the next step in the registration process. To register with a credential provider, the designated person must have the organization's DUNS number that will be entered in box 8a of the form SF-424, Application for Federal Assistance. The organization's DUNS number used must be identical to the DUNS number for the organization found in the CCR registration.

Since August 30, 2007, organizations can choose from three federally approved credential providers available from which to choose their authentication services: The Agriculture Department; the Office of Personnel Management's Employee Express; and Operational Research Consultants (ORC), Inc., which also provided authentication services prior to August 30, 2007. Until January 11, 2009, or shortly thereafter, users who already hold a Grants.gov user name and password through ORC will not experience much change. New users

will be able to choose from any of the three credential providers available.

- To register with a credential provider, go to <http://apply07.grants.gov/apply/ORCRegister>. Once you have accessed the site, scroll down the page and enter the DUNS number, and click on "Register."

- At the next screen, scroll down and select "Get Your Credentials."

- On the "eAuthentication User Information" screen, complete and submit all information.

- On the next screen, confirm your information and create your own user name and password. Then click "Submit." If all the information has been entered correctly, you will receive a notice of Registration Success.

(b) *Provision of Credentials by Grants.gov.* In January 2009, Grants.gov will be terminating service with the current Grants.gov credential provider, Operational Research Consultants (ORC). As a result of the change, Grants.gov will provide credentials (user name and passwords) to Grants.gov registrants.

(i) *New Grants.gov Registrants.* After January 2009, or when Grants.gov begins providing credential services, when clicking on the "For Applicants" link, new Grants.gov registrants will get a pop-up screen asking them to update their user profile. The information requested is similar to the information that was previously provided to ORC or one of the other credential providers. In addition to updating their user profile, registrants will be asked to enter a Secret Question and Secret Answer. The Secret Question and Secret Answer portion of the information provides for increased security for future inquiries about the registrants' account and allows registrants to reset their own password. Once created, users will be able to reset their password on their own. Previously, users needed to call the Grants.gov Help Desk to get a password or user name reset or go back to the credential provider to get a password they forgot.

(ii) *Existing/Legacy Registrants.* Grants.gov will retain the user name and password for existing/legacy registrants. However, existing/legacy registrants will have to update their profile by clicking on the "For Applicants" link, update their profile, and establish a Secret Question and Secret Answer. The automated user name and password reset feature will not work if the registrant has not updated his or her profile and created the Secret Question and Secret Answer.

(iii) *Forgot My User Name and Forgot My Password Links.* New and legacy applicants that updated their profile and

created a Secret Question and Secret Answer will be able to use the "Forgot My User Name" and "Forgot My Password" links on the Applicant Login screen to have their user name and password sent to them via email. To do so, they will have to know their DUNS number and email address to retrieve and reset their user name and password.

Note: Registration to use Grants.gov to submit a funding application on behalf of an organization is not complete until Steps Four and Five below are completed.

(c) *Steps for Checking your Credentials.*

(i) Prior to January 11, 2009, or when Grants.gov begins to offer credential provider services, if you want to check your credentials prior to submitting an application, you may go to <http://e-auth.orc.com/>. Once you are on the E-Authentication site, scroll down the page and click on the link "Check your Credentials." Then enter your user name and password. If you enter the correct information, you will receive a message that states, "You have successfully verified your registration." If you have forgotten your password, click on the link "User Administration" and select "Forgotten Password" located in the left margin. On the next screen, enter your user name and click "Submit." The next screen displays your secret question. Follow instructions on this screen and click "Submit." Your password has been reset.

(ii) After January 11, 2009, or when Grants.gov offers credential provider services, AORs who have updated their profile and created the Secret Question and Secret Answer as a Grants.gov registrant can log into Grants.gov and obtain or reset their registered user names and password, or reset their user name or password through the Grants.gov automated service. If an applicant organization has multiple users, each registered Grants.gov user will have to update his or her Grants.gov user profile and create a Secret Question and Secret Answer. Questions about the changes to the Grants.gov registration process should be directed to the Grants.gov Help Desk at 800-518-GRANTS.

(4) *Step Four: Register with Grants.gov.*

(a) Prior to January 11, 2009, or prior to when Grants.gov offers credential provider services, after completing Step 3, creating a user name and password with the credential provider, the person(s) named by the applicant organization to submit an application for funding on behalf of the organization, and which is registered

with a Credential Provider, must open an account with Grants.gov. Opening the account with Grants.gov identifies the person who, as an AOR for the organization seeking funding, is requesting permission to submit the application. The final step in the registration process is when the E-Biz POC for the applicant organization identified in Box 8a of the SF-424, Application for Federal Assistance actually grants authorization to the person identified as an AOR. (See Step Five below). To register with Grants.gov, go to <https://apply07.grants.gov/apply/GrantsgovRegister>.

After the proposed AOR registers his or her user name and password with Grants.gov, the organization's E-Biz POC will be sent an email indicating that someone has requested authority to submit an application for the organization and has registered as an AOR.

(b) After January 11, 2009, or when Grants.gov offers credential provider services, the person(s) named by the applicant organization to submit an application for funding on behalf of the organization must open an account with Grants.gov, or update their existing account. Opening the account with Grants.gov identifies the person as a proposed AOR seeking funding for the organization named in box 8a of the form SF-424, Application for Federal Assistance, and who is requesting permission to submit the application. To open an account, the proposed AOR must complete the profile information and create a Secret Question and Secret Answer at Grants.gov. An existing or legacy AOR can log into Grants.gov using his or her user name and password, update his or her profile, and create a Secret Question and Secret Answer. To register with Grants.gov, go to <https://apply07.grants.gov/apply/GrantsgovRegister>.

After the proposed AOR registers his or her user name and password with Grants.gov, the organization's E-Biz POC will be sent an e-mail indicating that someone has requested authority to submit an application for the organization and has registered as an AOR.

The final step in the registration process is when the E-Biz POC for the applicant organization identified in Box 8a of the SF-424, Application for Federal Assistance, actually grants authorization to the person identified as an AOR. (See Step Five below).

(5) *Step Five: Granting Approval of an AOR to Submit an Application on Behalf of the Organization.* The E-Biz POC must log into the Grants.gov Web site and give the registered AOR

approval to submit an application to Grants.gov. By authorizing the AOR to submit on behalf of the applicant organization, the E-Biz POC is stating that the person has the legal authority to submit the electronic application on behalf of the applicant organization and can make a legally binding commitment for the applicant organization.

(a) The E-Biz POC must approve the designated AOR(s). If the E-Biz POC does not grant authorization, Grants.gov will not accept the application. The E-Biz POC can designate the AOR to submit applications on behalf of the organization at <https://apply07.grants.gov/apply/AorMgrGetID>. The registration is complete when an AOR has been approved to submit an application on behalf of the applicant organization by the E-Biz POC.

HUD urges applicants to check with their E-Biz POC to make sure that they have been authorized to make a legally binding commitment for the applicant organization when submitting the application to Grants.gov. This is particularly important if, during the CCR registration renewal process, the E-Biz POC for the applicant organization has been changed. The new E-Biz POC will have to grant authorization to all AORs. You can search the CCR registration for the E-Biz POC by going to <https://www.bpn.gov/CCRSearch/Search.aspx>.

(b) AORs can track their AOR status at any time on Grants.gov by going to the Applicant home page at Grants.gov. In "Quick Links," log in as an applicant and enter your user name and password. If you have not been granted AOR status by the E-Biz POC, you should contact the E-Biz POC directly.

5. Instructions on How to Download an Application Package and Application Instructions.

Please note:

The following instructions are not applicable to Continuum of Care applicants because Continuum of Care applications are not submitted to Grants.gov. A complete explanation on how to find and apply for Continuum of Care grants in 2009 will be provided in the Continuum of Care Program NOFA. HUD does provide notification of the availability of the registration instructions, applications, or other information through the Grants.gov Web site. Grants.gov no longer offers its notification service. Grants.gov now offers RSS Feed Services. Applicants are advised to sign up for one of the RSS Feed Services, which will allow an applicant to be notified of new funding opportunities or modifications to an existing funding opportunity. Information on RSS Feed options can be

found at <http://www07.grants.gov/help/rss.jsp>. Applicants familiar with this technology may select any feed service listed on the Grants.gov site. However, to assist applicants with making a selection, HUD is offering these suggestions for one of the most popular services:

- *eMail with Microsoft Outlook Directions*
 - Open your Web browser and go to <http://www.grants.gov>.
 - In the upper right corner of the screen, select RSS.
 - In the middle of the page, click on the hyperlink in "Get an RSS Reader."
 - From the list of categories, select Windows.
 - Select blogbot for Outlook.
 - Select Download. A File Download dialog box will appear.
 - Select Run. (If you see a Security Warning dialog box, select Run.)
 - Run Setup Wizard accepting the default settings.
 - When the Setup Wizard is finished, open Outlook.
 - Look to see if a blogbot icon is visible in the tool bar area of Outlook.
 - If not:
 - Select View in the menu. Then select Toolbars. Click on blogbot. The blogbot icon should now be visible in your toolbars.
 - To subscribe to Grants.gov, direct your browser back to the Grants.gov RSS page.
 - Right-click on the orange icon next to *New/Modified Opportunities by Agency* or *New/Modified Opportunities by Category*.
 - Select Add to blogbot for Outlook. For each subscription blogbot, add a subfolder in Inbox\blogbot.
 - If the add blogbot for Outlook option does not appear, Select the feed to which you want to subscribe and copy the URL from the address box.
 - From the blogbot toolbar icon, select Subscriptions.
 - Paste the URL from Grants.gov into the RSS/Atom URL textbox.
 - Create a name in the Name textbox.
 - *Windows Environment Directions*
 - Direct your web browser to <http://www.jetbrains.com>.
 - Select Downloads at the top of the page.
 - Select Omea Reader.
 - A File Download dialog box will appear.
 - Select Run. (If you see a Security Warning dialog box, select Run.)
 - Accept the default settings in the Setup Wizard. Note: Omea installation may ask to reboot your computer. Accept the choice. When the reboot is complete, Omea Startup Wizard should open. If the Startup Wizard does not

start automatically, double-click on the Omea icon on your desktop to start it.

- Accept all defaults in the Wizard.
- When the Wizard is finished, OMEA Reader will start.
 - To view messages in groups, from the View menu, select Show Items in Groups.
 - After you have turned this option on, all items in the Items List will be displayed in groups and sorted according to which resource column is selected.
 - You can group your items by any column of the Items List.
 - *MAC Users Directions*
 - Direct Safari to <http://www.grants.gov>.
 - In the upper right corner of the screen, select RSS.
 - To view announcements in Safari, simply select one of the feed options, e.g., *New/Modified Opportunities by Agency* or *New/Modified Opportunities by Category*. The list of opportunities appears in Safari.
 - In the column on the right side of the page, select Subscribe in Mail.
 - Open Mail.
 - You should now have a folder under RSS named Grants Modified Opportunities List.
 - Filter the list by typing the Agency acronym or other term into the search box in the upper right corner.

Applicants that have not signed up for the RSS Feed notification service can search for a funding opportunity on Grants.gov by going to http://www07.grants.gov/applicants/find_grant_opportunities.jsp. On this page, you can do a basic search, browse by category, or browse by agency. If you are interested in HUD Grants, click on browse by agency and then scroll down the page until you see U.S. Department of Housing and Urban Development on the right column. When you click on the HUD agency name, you will come to a page with all the funding opportunities that are posted by HUD at that point in time. When you click on an opportunity, you will come to a page that provides a synopsis of the opportunity and which also identifies the Catalog of Federal Domestic Assistance (CFDA) Number for the Program, the Funding Opportunity Number and further down the page, a link to the full announcement. To download the application and instructions, follow the directions below, but first you must be sure you have Adobe Reader 8.1.3 installed. HUD's FY2009 applications use Adobe Reader.

a. *The Application Package and Application Instructions*. The general process for downloading, completing,

submitting, and tracking grant application packages is described at http://www07.grants.gov/applicants/apply_for_grants.jsp. To download the application and instructions, go to https://apply.grants.gov/forms_apps_idx.html and enter the CFDA Number, Funding Opportunity Number, or Funding Opportunity Competition ID for the application that you are interested in. If you enter more than one criterion, you will not find the instructions. You will then come to a page where you will find the funding opportunity *Download Application & Instructions* link. Before you can view and complete an application package, you must have a compatible Adobe Reader installed. Grants.gov is currently using Adobe Reader versions 8.1.2, 8.1.3, and 9.0. While the Grants.gov system supports all three versions of Adobe Reader, HUD applicants are advised they must download Adobe Reader 8.1.3 available from the Grants.gov Web site. HUD has been advised by Grants.gov that Adobe Reader 8.1.3 addresses the broken pipe error message and operates better than older versions of the reader, and the newer software results in faster uploads. Older versions, including Adobe Reader 9.0, do not solve the broken pipe issue. When Adobe Reader 9.1 is issued, it will address the broken pipe issue. To obtain Adobe 8.1.3 and check for compatibility with your system, go to http://www.adobe.com/products/acrobat/readstep2_allversions.html. At that site you can identify the software you have installed on your computer and follow the instructions for downloading the software compatible with your computer and associated to the instructions in this General Section for using Adobe Reader Version 8.1.3.

b. To check which version of Adobe Acrobat you are using, go to the Help menu in Adobe Acrobat and then select "About Acrobat." A text box will appear containing an Adobe logo with a number. Under that information, you will see another number; this is the version number of your software (e.g., 8.1.1, 8.1.2, or 8.1.3). If you do not have the correct version of Adobe Reader, go to http://www.adobe.com/products/acrobat/readstep2_allversions.html. System requirements for Adobe Reader 8.1.3 are listed as follows:

6. Adobe Reader 8.1.3 System Requirements.

- Windows
- Intel Pentium® III or equivalent processor
- Microsoft Windows 2000 with Service Pack 4; Windows Server 2003; Windows XP Professional, Home Edition, or Tablet PC Edition with

Service Pack 2 or 3; Windows Vista with or without Service Pack 1.

- 128MB of RAM (256MB recommended for complex forms or large documents).
 - 170MB of available hard-disk space.
 - Microsoft Internet Explorer 6.0 or 7.0, Firefox 1.5 or 2.0, Mozilla 1.7, AOL 9.
 - Macintosh
 - PowerPC G3, G4, G5, or Intel processor.
 - Mac OS X v10.4.11–10.5.5.
 - 128MB of RAM (256MB recommended for complex forms or large documents).
 - 170MB of available hard-disk space.
 - Safari 2.0.2.
 - Linux
 - 32-bit Intel Pentium processor or equivalent.
 - LSB (Linux Standard Base) 3.1 compliant systems including Red Hat® Linux WS 5, SUSE® Linux Enterprise Desktop (SLED) 10, and Ubuntu 6.10.
 - GNOME or KDE Desktop Environment.
 - 512MB of RAM (1GB recommended).
 - 125MB of available hard-disk space (additional 75MB required for all supported font packs).
 - GTK+ (GIMP Toolkit) user interface library, version 2.6 or later.
 - Firefox 1.5 or later, Mozilla 1.7.3 or later.
 - Solaris
 - UltraSPARC® or UltraSPARC IIIi® processor.
 - Solaris 9 or 10.
 - GNOME or KDE Desktop Environment (GNOME only for Solaris 10).
 - 512MB of RAM (1GB recommended).
 - 175MB of available hard-disk space (additional 75MB required for all supported font packs).
 - GNU C library (glibc) version 2.3 or later.
 - GTK+ (GIMP Toolkit) user interface library, version 2.6 or later (on Solaris 10; also works with GTK 2.4.9).
 - Firefox 1.5 or later, Mozilla 1.7.3 or later.
 - OpenGL library.
 - OpenSSL 0.9.7, OpenLDAP, and CUPS libraries.
 - libstdc++ library.
- a. You can use Adobe Reader 8.1.3 with Adobe Professional 6.0 or newer, provided you have updated the default setting on the copy of Adobe Professional on your computer so the Adobe Reader default setting matches Adobe Reader 8.1.3, which you have just downloaded from the Grants.gov Web site and installed on your computer.

b. Grants.gov has posted instructions in Frequently Asked Questions at http://grants.gov/applicants/applicant_faqs.jsp. Applicants should review these FAQs as it will assist them in making sure that they are properly set up to successfully submit an application. Applicants need to make sure that the default setting on their Adobe Reader is set to the new 8.1.3 version of Adobe Reader software downloaded from Grants.gov. Adobe Reader 8.1.3 is compatible with Adobe Professional 6.0 or higher. Applicants that need assistance can contact the Grants.gov Contact Center by phone at 1-800-518-GRANTS or via e-mail at support@grants.gov.

Critical Notice: Applicants must be aware that all persons working on Adobe Forms in the application package must work using the same Adobe Reader version available from Grants.gov. Please alert your staff and those working on your application that failure to download and use the correct Adobe Reader 8.1.3 or to update the Reader on Adobe Professional to 8.1.3 and meet the Grants.gov compatibility requirements contained in this General Section will result in your not being able to create or submit the application package to Grants.gov or your application being rejected by Grants.gov. Using incompatible versions of Adobe Reader will result in files being corrupted.

Next, download the application instructions by clicking on the Download Instructions link. The Instructions contain the General and Program Sections for the funding opportunity, as well as forms that are not part of the application download but are included as elements of a complete package, as specified in the published NOFA. After you have installed Adobe Reader 8.1.3, you can now download the application by clicking on the Download Application link. Both the instructions and application should be saved on your computer. You do not need to be registered to download the instructions or complete the application; however, once you have downloaded the application and intend to submit an application, you must save it on your computer or local network drive.

Each program NOFA also includes a checklist. Please review the checklist in the Program Section to ensure that your application contains all the required materials.

c. Electronic Grant Application Forms.

(1) Forms contained in the Instructions download are available in Microsoft Office Word 2003 (.doc),

Microsoft Office Excel 2003 (.xls), or Adobe (.pdf) formats. The .pdf files are only fillable forms and cannot be saved locally, unless you have Adobe Professional software version 6.0 or higher.

(2) To open the Application download, you must first install Adobe Reader 8.1.3. During the download process, the application automatically opens. If you have a version of Adobe Acrobat or Adobe Acrobat reader version 8.0 or older, the application will not open, and you will get an error message telling you to first install the correct version of the software. If you get an error message, follow the instructions in paragraph IV.B.5., Instructions on How to Download an Application Package and Application Instructions. The Application download will contain a cover page entitled "Grant Application Package." The cover page provides information regarding the application package you have chosen to download, i.e., Opportunity Title, Agency Name, CFDA Number, etc. Review this information to ensure that you have selected the correct application. The Grant Application cover page separates the required forms into two categories: "Mandatory Documents" and "Optional Documents." To complete a form from either the "Mandatory Documents" or "Optional Documents," you must first highlight and move the form over to the "Submission" box and then open the form.

(3) Please note that regardless of the box in which the forms are listed, the published General Section and Program Section NOFA (and any technical corrections) in the **Federal Register** documents are the official documents HUD uses to solicit applications. Therefore, applicants should follow the instructions provided in the General Section and Program Sections of the Instructions download. The individual NOFA sections will also identify the forms that may be applicable and that need to be submitted with the application.

(4) Because you will be adding additional attachment files to the downloaded application, applicants should save the application to their local computer or network drive. Do not download the application or attempt to upload the application using a USB flash drive (also called a "key drive," "thumb," or "jump drive"), because Grants.gov has found that applicants have problems uploading applications and attachments from a USB flash drive. Be sure to read and follow the application submission requirements published in each individual NOFA for

which you are submitting an application. Each program NOFA will identify all the required forms and other required information for submission.

(5) HUD's standard forms are identified below:

(a) Application for Federal Assistance (SF-424);

(b) Faith-Based EEO Survey (SF-424 Supplement, Survey on Ensuring Equal Opportunities for Applicants), if applicable;

(c) HUD Detailed Budget (HUD-424-CB, Grant Application Detailed Budget);

(d) Grant Application Detailed Budget Worksheet (HUD-424-CBW);

(e) Disclosure of Lobbying Activities (SF-LLL), if applicable;

(f) HUD Applicant Recipient Disclosure Report (HUD-2880, Applicant/Recipient Disclosure/Update Report);

(g) Certification of Consistency with RC/EZ/EC-II Strategic Plan (HUD-2990), if applicable;

(h) Certification of Consistency with the Consolidated Plan (HUD-2991), if applicable;

(i) Acknowledgment of Application Receipt (HUD-2993);

(j) You Are Our Client Grant Applicant Survey! (HUD 2994-A) (Optional);

(k) Program Outcome Logic Model (HUD-96010);

(l) HUD Race Ethnic Form (HUD-27061), if applicable; and

(m) HUD Facsimile Transmittal (HUD-96011, Third Party Documentation Facsimile Transmittal).

All HUD "program-specific" forms not available at the Application download will be available in the Instructions download in Microsoft Word Office 2003 (.doc), Microsoft Excel Office 2003 (.xls), or Adobe (.pdf) format, compatible with Adobe Reader 8.1.3. The PDF forms are fillable but not savable, unless you have Adobe Professional 6.0 or higher. Applicants may use the HUD-96011, "Third Party Documentation Facsimile Transmittal" ("HUD Facsimile Transmittal" on Grants.gov) form and fax to HUD any forms they have completed but cannot save.

7. Instructions on How to Complete the Selected Grant Application Package.

a. *Ensure You Have the Correct Application Downloaded.* Applicants must check the application to ensure that the application they have downloaded matches the CFDA Number, Funding Opportunity Number, and Competition ID for the funding opportunity under which the applicant is requesting funds. In FY2009, if HUD receives an application submitted under the wrong application package, HUD

will rate the application under the funding competition ID on the SF-424 for the submitted application. Please pay careful attention to which application you submit. The CFDA number, Funding Opportunity Number, and Competition ID are located on the front page of the downloaded application. If you download the wrong application, and it is prior to the deadline date, simply go back to Grants.gov and obtain the correct application and resubmit.

b. *Mandatory Fields on Application Download Forms.* Forms in the

Application download contain fields with a yellow background. These data fields are mandatory and must be completed. Failure to complete the fields will result in an error message when checking the package for errors.

c. *Completion of SF-424 Fields First.*

The forms in the application package are designed to automatically populate common data such as the applicant name and address, DUNS number, etc. In order to trigger this function, the SF-424 must be completed first. Once applicants complete the SF-424, the entered information will transfer to the other forms.

d. *Submission of Narrative Statements, Third-Party Letters, Certifications, and Program-Specific Forms.* In addition to program-specific forms, many of the NOFAs require the submission of other documentation, such as third-party letters, certifications, or program narrative statements. This section discusses how you should submit this additional information electronically as part of your application:

(1) *Narrative Statements to the Factors for Award.* If you are required to submit narrative statements, you must submit them as an electronic file in Microsoft Word Office 2007 (or earlier) (.doc), Microsoft Excel 2007 (or earlier) (.xls), or in Adobe (.pdf) format that is compatible with Adobe Reader 8.1.3. If HUD receives a file in a format or software other than those specified or that is not compatible with HUD software, HUD will not be able to read the file, and it will not be reviewed. Each response to a Factor for Award should be clearly identified and can be incorporated into a single attachment or all attachments can be zipped together into a single attached ZIP file. However, HUD advises applicants that files zipped within zipped files cause problems and can result in the application attachments not able to be opened or read. Applicants should develop files, then zip the files together, and then place them as an attachment to the application. If you have any

questions, you can contact the NOFA Information Center or the HUD program contact listed in the program NOFA.

Documents that applicants possess in electronic format, e.g., narratives they have written, must be submitted as Microsoft documents; graphic images (such as computer aided design (CAD) files from an architect) must be saved in PDF format. The documents must be compatible with Adobe Reader 8.1.3 and attached using the "Attachments" form included in the application package downloaded from Grants.gov. In addition, some NOFAs may request photographs. If this is the case, then the photographs should be saved in .jpg or .jpeg format and attached using the "Attachments" form. When creating attachments to your application, please follow these rules:

(a) Do not attach a copy of the electronic application with your attachments as an attachment file. HUD cannot open such files when the application is attached as an attachment file.

(b) Check the attachment file and make sure it has a file extension of .doc, .pdf, .xls, .jpg, or .jpeg or, if you save files in Microsoft Office 2007, the file extensions should be as follows:

Word 2007 File Type Extension

- docx—Word 2007 XML Document

Excel 2007 File Type Extension

- xlsx—Excel 2007 XML Workbook

PowerPoint 2007 File Extension Type

- pptx—PowerPoint 2007

(c) Make sure that file extensions are not in upper case. File extensions must be lower case for the file to be opened. The software will automatically insert the correct file extension when saved.

(d) Do not adjust file extensions to try to make them conform to HUD standards. If you have problems, please contact the HUD contact listed in the NOFA.

(e) Do not use special characters (i.e., #, %, /, etc.) in a file name.

(f) Do not include spaces in the file name.

(g) Limit file names to not more than 50 characters. HUD recommends that file names be no more than 32 characters.

(h) Do not convert Word files or Excel files into PDF format. Converting to PDF format increases file size and will make it more difficult to upload the application and does not allow HUD to enter data from the Excel files into a database.

(i) Do not submit applications larger than 150 megabytes. These file sizes are difficult to upload and HUD cannot

guarantee that they can be processed, as its system has not been tested with files larger than 150 megabytes.

Failure to follow the directions for items (e), (f), and (g) will result in your application being rejected with a "VirusDetect" error message.

(2) ZIP Files. In order to reduce the size of attachments, applicants can compress several files using a ZIP utility. Applicants can then attach the zipped file as described above. HUD's standard zip utility is WinZip. Files compressed with the WinZip utility must use either the "Normal" option or "Maximum (portable)" option available to ensure that HUD is able to open the file. Files received using compression methods other than "Normal" or "Maximum (portable)" cannot be opened and will not be reviewed. Applicants should be aware that if HUD receives files compressed using another utility, or not in accord with these directions, it cannot open the files and, therefore, such files will not be reviewed.

(3) *Third-Party Letters, Certifications Requiring Signatures, and Other Documentation.* Applicants required to submit third-party documentation (e.g., establishing matching or leveraged funds, documentation of 501(c)(3) status or incorporation papers, documents that support the need for the program, Memorandums of Understanding (MOUs), or program-required documentation that supports your organization's claims regarding work that has been done to remove regulatory barriers to affordable housing) can choose from the following two options as a way to provide HUD with the documentation:

(a) Scanning Documents to Create Electronic Files. Scanning documents increases the size of files. If your computer has the memory and capacity to upload scanned documents, submit your documents with the application by using the Attachments form in the Mandatory or Optional Forms section of the application. If your computer does not have the memory to upload scanned documents, you should submit them via fax, as described below. Electronic files must be labeled so that the recipient at HUD will know what the file contains. Program NOFAs will indicate any naming conventions that applicants must use when submitting files using the Attachments form. Please note that if you do not follow the file name limit of not more than 50 characters, and the prohibition of using spaces and special characters in the file name, the Grants.gov system will treat these files as though they had a virus and the application will be rejected with a

"VirusDetect" error message. If an applicant received a "VirusDetect" error message and the package has been checked for viruses, applicants should check their attachment file names for length, delete any spaces, and delete any special characters. HUD also recommends that file names be no more than 32 characters. Once the deficiencies have been addressed, applicants should save the application file, and the newly renamed attachments, and close the application down. Remove any cookies, reboot your computer, and then submit the application. Grants.gov advises submitting the application from Internet Explorer.

(b) Faxing Required Documentation. Applicants may fax the required documentation as program-specific forms to HUD. Applicants should use this method only when documents cannot be attached to the electronic application package as a .pdf, .doc, .xls, .jpeg, or .jpg, or when the size of the submission is too large to upload from the applicant's computer. If an applicant is trying to submit the application including scanned documents, and the application does not upload quickly to Grants.gov, HUD advises the applicant to either reconvert the scanned documents back to Microsoft Word or Excel files or send the attachments in using the fax methodology, because size of the scanned attachment files may be exceeding the capacity of your computer or your internet server to process the files and obtain a successful upload to Grants.gov.

HUD will not accept entire applications by fax and will disqualify applications submitted entirely in that manner.

(i) Fax form HUD-96011, "Third Party Documentation Facsimile Transmittal" (HUD Facsimile Transmittal on Grants.gov). Facsimiles submitted in response to a NOFA must use the form HUD-96011. The facsimile transmittal form, found in the downloaded application, contains a unique identifier that allows HUD to match an applicant's submitted application via Grants.gov with faxes coming from a variety of sources. Each time the application package is downloaded, the forms in the package are given a unique ID number. To ensure that all the forms in your package contain the same unique ID number, after downloading your application, complete the SF-424, save the forms to your hard drive, and use the saved forms to create your application. When you have downloaded your application package from Grants.gov, be sure to first complete the SF-424, and then provide

copies of the form HUD-96011 to third parties that will submit information in support of your application. Do not download the same application package from Grants.gov more than once, because if your application submission does not match the unique identifier on the facsimile transmittal form, HUD will not be able to match the faxes received to your application submission. Faxes that cannot be matched to an application will not be considered in the review process.

If you have to provide a copy of the form HUD-96011 to another party that will be responsible for faxing an item as part of your application, make a copy of the facsimile transmittal cover page from your downloaded application and provide that copy to the third party for use with the fax transmission. Please instruct third parties to use the form HUD-96011 that you have provided as a cover page when they submit information supporting your application using the facsimile method, because it contains the embedded ID number that is unique to your application submission.

(ii) Use Form HUD-96011 as the Fax Cover Page. For HUD to correctly match a fax to a particular application, the applicant must use, and require third parties that fax documentation on its behalf to use, the form HUD-96011 as the cover page of the facsimile. Using the form HUD-96011 will ensure that HUD can electronically read faxes submitted by and on behalf of an applicant and can match them to the applicant's application package received via Grants.gov.

Failure to use the form HUD-96011 as the cover page will create a problem in electronically matching your faxes to the application. If HUD is unable to match the faxes electronically due to an applicant's failure to follow these directions, HUD will not hand-match faxes to applications and will not consider the faxed information in rating the application. If your facsimile machine automatically creates a cover page, turn this feature off before faxing information to HUD.

(iii) HUD Fax Number. Applicants and third parties submitting information on their behalf must use the form HUD-96011 facsimile transmittal cover page and must send the information to the following toll-free fax number: 800-HUD-1010. If you cannot access the toll-free 800 number or experience problems, you may use 215-825-8798 (this is not a toll-free number). These are new numbers for FY2009 applications only. If you use the wrong fax number, your fax will be entered as part of HUD's FY2008 database. HUD cannot

search its FY2008 database to match FY2009 faxes to FY2009 applications. As a result, your application will be reviewed without faxed information if you fail to use the FY2009 fax numbers.

(iv) Fax Individual Documents as Separate Transmissions. It is highly recommended that applicants fax individual documents as separate submissions to avoid fax transmission problems. When faxing two or more documents to HUD, applicants must use the form HUD-96011 as the cover page for each document (e.g., Letter of Matching or Leveraging Funds, Memorandum of Understanding, Certification of Consistency with the Consolidated Plan, etc.). Please be aware that faxing large documents at one time may result in transmission failures.

(v) Check Accuracy of Fax Transmission. Be sure to check the record of your transmission issued by the fax machine to ensure that your fax submission was completed "OK." For large or long documents, HUD suggests that you divide them into smaller sections for faxing purposes. Each time you fax a document that you have divided into smaller sections, you should indicate on the cover sheet what part of the overall section you are submitting (e.g., "part 1 of 4 parts" or "pages 1 to 10 of 20 pages").

Your facsimile machine should provide you with a record of whether HUD received your transmission. If you get a negative response or a transmission error, you should resubmit the document until you confirm that HUD has received your transmission. HUD will not acknowledge that it received a fax successfully. When receiving a fax electronically, HUD will electronically read it with an optical character reader and attach it to the application submitted through Grants.gov. Applicants and third parties submitting information on their behalf may submit information by facsimile at any time before the application deadline date. Applicants must ensure that the form HUD-96011 used to fax information is part of the application package downloaded from Grants.gov. As stated previously, if your facsimile machine automatically generates a cover page, you must ensure that you turn that feature off and use the form HUD-96011 as the cover page. Also ensure that the fax is transmitted to fit 8½" x 11" letter-size paper.

(vi) Preview Your Fax Transmission. HUD recommends that you "preview" how your fax will be transmitted by using the copy feature on your facsimile machine to make a copy of the first two or three pages. This way, you will see what HUD will receive as a fax. If the

fax is not clear or cuts off at the bottom of the page, applicants should use a different facsimile machine or have the machine adjusted. All faxed materials must be received no later than 11:59:59 p.m. eastern time on the application deadline date. HUD will store the information and match it to the electronic application when HUD receives it from Grants.gov. If you are not faxing any documents, you must still complete the facsimile transmittal form. In the section of the form titled "Name of Document Transmitting," enter the words "Nothing Faxed with this Application." Complete the remaining highlighted fields and enter the number "0" in the section of the form titled "How many pages (including cover) are being faxed?"

(vii) If You Resubmit an Application. Please be aware that a resubmitted application must meet the timely receipt requirements of this notice.

8. *Steps To Take Before You Submit Your Application.* Approximately one week before submitting an application, each applicant should configure its proxy and cache servers to ensure transmission of its application to Grants.gov. Grants.gov uses HTTP post protocols on port 80 (your technical support will be able to assist). Prior to submitting, applicants should review the application package and all the attachments to make sure the application contains all the documents the applicant wants to submit. If it does, save it to your computer and remove previously saved versions. Check your AOR status on Grants.gov to make sure your eBusiness POC has authorized you to submit an application on behalf of the applicant organization. Run the Check Package for Errors feature on the application package and correct any problems identified. Contact any persons or entities that were to submit third-party faxes to make sure that the faxes have been submitted using the facsimile cover page that you provided in accordance with instructions in this General Section. Check your e-mail system to ensure that it allows receipt of messages from Support@grants.gov. Microsoft Outlook users can set their e-mail to receive messages from Support@grants.gov going to their e-mail Inbox, clicking on "Actions" and selecting "Junk E-mail", and then selecting "Junk E-mail Options." A dialog box will come up. Click "OK." Another dialog box will appear and select the "Safe Senders" folder. Then add [@grants.gov](mailto:grants.gov) to the list of acceptable e-mail domains. Click "OK." Applicants not using Microsoft Outlook should check with their software provider or IT staff to get directions on how to allow

e-mail from Grants.gov to come into your Inbox. This is critical as notices of receipt, validation, or rejection are sent by e-mail. Grants.gov sends the e-mail notification to the e-mail address registered during the registration process. The e-mail from Grants.gov does not go to the contact name listed on the SF-424 Application for Federal Assistance, but to the person designated in the registration at Grants.gov. Also check your Trust Manager to ensure that it will allow files to go to all sites. To enable Trust Manager, follow the steps below:

- a. Click on Edit;
- b. Then click on Preferences;
- c. Then click Trust Manager in the left-hand pane;
- d. Click on Change Settings on the ensuing window;
- e. Select allow all sites listed toward the top of the page;
- f. Click on OK;
- g. Click on JavaScript on the left-hand side of the screen;
- h. Make sure everything is checked here except for things under the Debugger heading (do not change);
- i. Click on OK until you get out of the preferences windows;
- j. When this has been done, you can try submitting your application. Click "Allow" on the pop-up window.

C. Receipt Dates and Times

Please note: Applicants under the Continuum of Care program should follow the directions for application submission and timely receipt that are contained in the Continuum of Care program NOFA. The instructions below apply only to applicants submitting applications via the federal portal <http://www.Grants.gov>.

1. The application deadline for receipt of HUD applications via Grants.gov is 11:59:59 p.m. on the date identified in the published program NOFA. As a result, applications must be received by Grants.gov by the deadline in order to meet the program NOFA deadline. Received means that the application has been successfully uploaded to the Grants.gov server and the applicant has received confirmation of successful submission to Grants.gov. Applicants should be aware that hitting the "sign and submit" button to transmit the application does not mean the application has been successfully uploaded to Grants.gov. Only when the upload is complete is the application date and time stamped by the Grants.gov system. An application that has been rejected by Grants.gov is not deemed to have been received by Grants.gov. (Please see Section D.1. below for a detailed explanation of Timely Receipt Requirements and Proof

of Timely Receipt.) As in the past, HUD encourages applicants to submit their applications early and with sufficient time to address any issues that might affect the applicant's ability to have an application successfully uploaded and received by Grants.gov.

In FY 2009, HUD is establishing a one-day grace period from the date of notification of a rejection from Grants.gov, to allow applicants that successfully upload an application to Grants.gov prior to the deadline date and time, but receive a rejection notice after the deadline date and time, to cure the reason for rejection and re-upload the application to Grants.gov. The paragraphs below describe HUD's Grace Period Policy for FY2009.

a. Applicants that have successfully uploaded their application to Grants.gov prior to the deadline, and subsequently receive a rejection notice from Grants.gov after the deadline date and time, will have a one-day grace period from the date stamp on the first Grants.gov rejection notice after the deadline, to cure the basis for the rejection and upload an application that corrects the problems cited in the rejection notice. Applicants can upload the application as many times as needed to cure noted deficiencies within the one-day grace period. The Grants.gov rejection notice identifies the reasons why the application was rejected. Applicants that do not understand the error messages received in the rejection notice should immediately contact the Grants.gov Help Desk so they can get assistance in clearing the problem. Generally, Grants.gov will reject an application because it contains an incorrect DUNS number or a DUNS number that does not match the AOR's registration, the application was submitted by an individual without proper authorization as the AOR, and/or the application contains file names that trigger a "VirusDetect" message. The grace period ends one day after the date stamp on the first rejection notice received after the deadline date.

Warning: Applications that contain file names which are longer than 50 characters (HUD recommends using file names with 32 characters or less), or contain spaces or special characters, will result in the file being detected as a virus by the Grants.gov system and the application will be rejected with a "VirusDetect" message. In FY2008, the use of spaces and special characters in file names, and the use of file names which were longer than fifty characters, resulted in the most instances of an applicant receiving a "VirusDetect" rejection. Applicants should also scan

files for viruses because the Grants.gov system will also reject files with viruses.

Applications received by Grants.gov, including those received during the grace period, must be validated by Grants.gov to be rated or ranked or receive funding consideration by HUD. HUD will use the date and time stamp on the Grants.gov system to determine dates when the grace period begins and ends.

b. Applications uploaded to Grants.gov after the deadline date under the following circumstances do not qualify for the grace period and will not be considered for funding:

(1) Applications uploaded and received by Grants.gov after the deadline date and time for which there is no prior rejection notice in the Grants.gov system logs will be considered late and will not be rated and ranked or receive funding consideration. Failure to successfully upload the application to Grants.gov by the deadline date and time does not qualify for the grace period as described above.

(2) Applications receiving a rejection notice due to the funding opportunity being closed will not be provided the one day grace period to correct the "opportunity closed" deficiency or any other basis for rejection because the applicant missed the deadline date and time and therefore does not qualify for the grace period as described above.

(3) If an application is uploaded during the grace period and is subsequently rejected after the grace period ends, the applicant will not be afforded additional time to correct the deficiency(ies) noted in the rejection notice.

c. The grace period ends at 11:59:59 p.m. one day from the date stamp on the first rejection notice issued by the Grants.gov system to the e-mail address provided in the Grants.gov registration. Applicants must ensure that their e-mail notification address contained in the Grants.gov registration is up-to-date. Neither HUD nor Grants.gov will be responsible if e-mail messages are not received at the address listed in the registration process. Applicants must also ensure that their e-mail systems will accept messages from Grants.gov. Applicants are responsible for monitoring their e-mail messages. Messages from Grants.gov come from Support@grants.gov.

d. The only exceptions to HUD's grace period policy are:

(1) The Grants.gov system is down and not available to applicants for at least 24 hours prior to the deadline date, or the system is down for 24 hours or longer, impacting the ability of

applicants to cure a submission deficiency within the grace period; and/or

(2) There is a presidentially declared disaster in the applicant's area. In the event of either or both of these events, HUD will publish a notice extending the deadline or cure period, for applicants affected, as appropriate.

e. Busy servers or slow processing are not the basis for HUD to extend the deadline dates or the grace period.

Applicants are advised to monitor the Grants.gov system using the Grants.gov blog at <http://grants.gov.blogspot.com/>. The Grants.gov blog provides information on server capacity, traffic on the Grants.gov site, and other federal grant closings each day. Applicants should monitor the site and take into account the amount of traffic on the site when applying.

2. An applicant will not be provided additional opportunities to correct rejection errors if an application is rejected after the one-day grace period has expired.

As with any electronic system, applicants may experience issues when attempting to submit their application which does not permit the uploading of the application to Grants.gov. Such issues can be due to firewall and virus protection software that the applicant has placed on their system or network; proxy and cache settings; Internet traffic; limitation on the size of the files attempting to be transmitted established at the applicant's site or by the applicant's Internet provider; Grants.gov servers experiencing busy traffic; or any number of issues. Therefore, HUD strongly advises applicants to submit their applications at least 48 hours prior to the deadline and when the Grants.gov Help Desk is open so that assistance can be provided. Assistance may require diagnosing an applicant's particular issues. An applicant that does not follow HUD's advice increases the applicant's risk of not being able to meet the timely receipt requirements. A submission attempt less than the recommended 48 hours before the deadline does not allow the time needed to research the reason for the problem or to work with the applicant in overcoming the uploading difficulty. Similarly, attempting to submit within 24 hours of the deadline or when the Grants.gov Help Desk is closed does not allow the time needed for Grants.gov or HUD to provide the needed assistance. In addition, HUD staff cannot provide assistance or contact Grants.gov on your behalf after the Help Desk is closed.

3. *Grants.gov Application Processing Steps and Notifications.*

After successful upload of an application to Grants.gov, the following processes will occur:

a. *Confirmation of Submission to Grants.gov.* When an application is successfully uploaded to Grants.gov, the AOR submitting the application will receive a confirmation screen on his or her computer that informs the submitter that the application has been successfully uploaded to Grants.gov and is being processed. This confirmation will include a tracking number. Print this confirmation out and save it for your records. If you submitted multiple applications, check your confirmation for each application submitted. The tracking number, CFDA Number, and Funding Opportunity Number, as well as the date and time of submission will appear on the confirmation. If you do not receive this confirmation, it usually means that your application has not been successfully uploaded. If your screen goes blank or you have problems uploading or your computer is not saving files, it usually means that your computer does not have sufficient memory or processing capability to store and upload the application. If you experience these difficulties, you should go to <http://www.grants.gov> and log in using your user name and password, and then click on "Check Application Status." If your application does not appear, you should immediately call Grants.gov support at 800-518-GRANTS for assistance (this is a toll-free number). If the Help Desk is closed, you should try reducing the size of your application or temporarily taking files off your computer to reduce the demand on your system. The files that were removed can be placed back on your system after uploading the application. (See information on Adobe Version 8.1.3 system requirements contained in section IV.B.6 of this General Section.) HUD also recommends checking to ensure that the applicant's firewalls and anti-virus software allows access to the Grants.gov system.

b. *Application Submission Validation Check.* The application will then go through a validation process. The validation check ensures that:

(1) The application is virus free (this includes that the file names comply with the required size limits and spacing and special characters limitations);

(2) The application meets the deadline requirements established for the funding opportunity (this includes the grace period and conditions cited earlier in this notice);

(3) The DUNS number submitted on the application matches the DUNS number in the registration, and that the

AOR has been authorized to submit the application for funding by the organization identified by its DUNS number;

(4) The AOR has been authorized by the applicant's E-Biz POC to submit the application;

(5) All the mandatory (highlighted) fields and forms were completed on the application; and

(6) The correct version of Adobe Reader was used in completing the application package forms.

c. *Application Validation and Rejection Notification.* If the application fails any of the above items during the validation check, the grant application will be rejected and Grants.gov will send an e-mail to the person denoted by the applicant in the registration process to receive e-mail notifications from Grants.gov. The e-mail will indicate that the grant application has been rejected. The e-mail will also include the reasons why the application was rejected. The e-mail will come from Support@Grants.gov. The validation check can occur 24 to 48 hours after the application submission.

d. *Applicants receiving a rejection notice have the opportunity to cure the rejection under the terms and provisions listed under HUD's grace period policy.*

4. *Receipt Dates and Times.*

a. *Timely Receipt Requirements and Proof of Timely Submission.*

(1) *Proof of Application Receipt.* Receipt times and rejection notifications are automatically recorded by Grants.gov. An electronic time stamp is generated within the system when the application has been successfully received, the application has been validated, or when an application has been rejected. HUD will use these date stamps to determine whether an application meets the timely receipt requirements.

(2) *Confirmation Receipt.* Upon submitting an application at Grants.gov, the person submitting the application will see a confirmation screen appear on their computer. The confirmation advises the submitter that the application has been successfully uploaded to Grants.gov. This confirmation will also include the Grants.gov tracking number. Print the confirmation and save it with your records. If you do not receive the Confirmation screen, go to <http://www.Grants.gov>, and using the AOR user name and password, click on "Check Application Status." If there is no data to display for the submitted application, the application was not successfully uploaded and not received by Grants.gov.

(3) *Grants.gov Receipt E-mail*. Shortly after displaying the successful submission Confirmation screen, Grants.gov will send a Receipt Notice to the e-mail address listed in the registration. The Receipt Notice will identify the application submitted and the date and time it was received by Grants.gov. HUD will use this date and time stamp to determine if the application was received by Grants.gov in accord with the timely submission requirements in this notice. The Receipt Notice merely acknowledges that an application was received. The next step in the process is the validation of the registration information against the DUNS number information and the applicant electronic signature in the application submitted to Grants.gov; and a check to see that there are no viruses in the application or that the attachment files met the file-naming conventions contained in this notice so as to be compatible with the Grants.gov system.

(4) *Validation Receipt via E-mail*. Within 24 to 48 hours after receiving the Receipt Notice e-mail, the applicant will receive a validation receipt or rejection notice via e-mail. The validation receipt indicates that the application has passed the validation review at Grants.gov and that the application is ready to be retrieved by the grantor agency for agency processing. Please be aware that the Grants.gov validation does not indicate that the grantor agency has reviewed the content of your application; rather, the validation merely indicates that the application has been successfully received and is ready for pickup by the grantor agency.

(5) *Rejection Notice*. If an application fails the validation process, the applicant is sent a rejection notice within 24 to 48 hours after the notification of receipt by Grants.gov. The e-mail notification will be sent to the e-mail address registered in the Grants.gov system to receive e-mail notifications. The applicant should review the rejection notice because it will include the reason(s) for rejection. If the rejection notice is received prior to the deadline date, the AOR should try to cure the deficiencies identified and resubmit the application as soon as possible prior to the deadline. If the rejection notice is received after the deadline date, the AOR should try to cure the deficiencies identified and resubmit the application prior to the end of the grace period. The most common rejection notices are:

(a) *Invalid DUNS*.

"The DUNS number entered in your package is invalid or does not match the DUNS number that is registered with

the Central Contractor Registry (CCR). Please verify that the DUNS number is entered correctly, and is the same as in your Central Contractor Registry (CCR) registration."

(b) *Password ID*.

If the submitter submits using a password not associated with the User ID or if the submitter forgets or confuses the password, the submitter will not be able to log onto Grants.gov. Attempts to log on using the wrong password/ID combination will result in a pop-up JAVA Script Window with a Warning Notice. The notice states "Grants.gov cannot log you in with the provided credentials. You have made 1 of 3 allowed failed logins. Please verify your user name and password and attempt to login again." Applicants can get their password reset by going to their credential provider, obtaining a new password, registering that password at Grants.gov and having the E-Biz Point of Contact authorize the submitter as an AOR to submit the application under the applicant DUNS number using the registered credentials.

(c) *Not Authorized*.

(i) A User that uses a User ID/Password combination that is registered but has not been authorized by the applicant's E-Biz POC will receive a rejection message that states, "You are not designated by your organization to be an Authorized Organizational Representative and your application cannot be validated. You either have not successfully completed the registration process or your E-Biz POC has not authorized you to submit on behalf of your organization." To verify whether you have been successfully registered with Grants.gov, click <https://apply07.grants.gov/apply/ApplicantLoginGetID>. To check to see if you have been designated by the E-Biz POC as an AOR, go to http://www.grants.gov/applicants/org_step6.jsp.

(ii) Applicants that may have an authorized user name/password but who enter the DUNS number incorrectly, or who use a DUNS number that they have not been authorized to use, will receive the "NOT AUTHORIZED" rejection in combination with the invalid DUNS message.

(iii) Individuals who attempt to apply for a grant for which individuals are not an eligible applicant, will receive the Not Authorized and Invalid DUNS rejection notices, plus a third rejection notice that states: "The grant opportunity for which you have applied is designated for Authorized Organization Representatives (AOR) only. However, your application or a

grant/grants was not submitted on behalf of a company, organization, institution, or government. An AOR submits a grant on behalf of a company, organization, institution, or government. AORS have the authority to sign grant applications and the required certifications and/or assurances that are necessary to fulfill the requirements of the application process."

(d) *VirusDetect*.

A VirusDetect rejection message can be received if the application contains a virus or if the application submission contains files which do not meet the file-naming conventions stated in this notice.

(6) *Most Common Reasons for Rejection*. HUD has found that the most common reason for rejection of an application by Grants.gov was the failure of the applicant to be authorized by their E-Biz POC to submit the application on behalf of the applicant organization. Fifty-nine percent of the rejection notices contained the unauthorized notice alone, indicating that they had used the correct DUNS number but had not completed all the steps in the registration process. The second-most common error was the use of spaces, special characters and file names longer than fifty characters in an attachment file name. Use of spaces, special characters, or file names that are longer than fifty characters will result in a "VirusDetect" error. Twenty-three percent of the rejections were due to "VirusDetect" errors. The third-most common error was not submitting the application using the correct DUNS number associated to the applicant organization for which the applicant was the authorized AOR. Six percent of the rejected applications failed validation for using a DUNS number that did not match the information in the Grants.gov registration. Use of a DUNS number that does not match the registration information results in three error messages.

(7) *Save and File Receipts*. Applicants should save all receipts from Grants.gov, as well as facsimile receipts, for proof of timely submission. Applicants will be considered meeting the timely submission requirements based upon the requirements in section IV.C., Receipt Dates and Times, and when all fax transmissions have been received by 11:59:59 p.m. on the deadline date stated in the program NOFA.

(8) *Checking the Status of Your Application Online*. Grants.gov allows applicants to check the status of their application online. To check your application status, log on at <http://www.grants.gov> and click on Applicant Login, and then enter your user name

and password. Next, click on "Check Application Status." All applications submitted by the applicant with the user name and password entered in the login screen will be identified and the status will be displayed. Applicants are obligated to check the on-line status of their application if they do not receive an immediate confirmation notice or an email notice of receipt as well as validation. HUD advises applicants to use this service to make sure the application was received by Grants.gov in accordance with section IV.C., entitled "Receipt Dates and Times," and to track the application to see if it is validated or rejected by Grants.gov. Applications submitted after the one day grace period stipulated in Section IV.C., Receipt Dates and Times, will be considered late and will not receive funding consideration.

(9) *Understanding the Status Messages.* If the application has not been uploaded or received by Grants.gov, the status message will state, "No data to display." Applicants seeing this message should attempt to submit their application if the deadline date has not passed. HUD will not accept an application that is received after the deadline date and time, if there is no prior record of a rejection notice.

If an application has been received, Grants.gov will note on the "Application Status" display that the application has been received. If the application has been received and validated, the status will display as validated.

If an application has been rejected, the status will display that the application has been rejected with errors and the applicant should click on the rejection to see what the error message was or should consult his or her email for the reasons for the rejection.

If an application has been received by HUD, the status will note that the application has been received by the granting agency.

When HUD assigns a tracking number, the status will indicate that the agency has assigned a tracking number.

Applications are not received by HUD until HUD pulls the application from Grants.gov. As long as the application shows validated by Grants.gov in accordance with the timely receipt requirement stated in this notice, applicants should not be concerned that the application was not received by HUD or not assigned a tracking number. That step of the process will occur when HUD pulls the applications from the Grants.gov site into its backend system.

(10) *Grants.gov Support Ticket Numbers.* If you call the Grants.gov

Support Help Desk, the operator will provide you with a call reference ticket number. Applicants should retain a record of the call ticket number(s) along with the application receipts or rejection notices received from Grants.gov. If the Help Desk does not offer a ticket number, ask for one.

b. Late applications.

(1) Applications received by Grants.gov after the program NOFA deadline date or that do not meet the requirements of HUD's grace period policy will be considered a late application and will not be considered for funding. Applicants should pay close attention to the grace period policy and the timely receipt instructions, as they can make a difference in whether HUD will accept the application for funding consideration.

(2) HUD will not consider application information submitted by facsimile as part of the application, if received by HUD after the published deadline date, unless directed by HUD under the terms of paragraph V.B.4., Corrections to Deficient Applications. There is no grace period for submission of facsimile transmissions, as the facsimile system is not part of Grants.gov. HUD now has the ability to match the facsimile transmission to the last application received and validated in accordance with the deadline requirements. Please take into account the transmission time required for facsimile documents related to your application.

HUD recommends that applicants submit their applications during the operating hours of the Grants.gov Help Desk so that, if there are questions concerning transmission, operators will be available to assist you through the process. Submitting your application early and during the Help Desk hours will also ensure that you have sufficient time for the application to complete its transmission before the application deadline. If you try to submit your application after the Grants.gov Support Help Desk closes, please refer to HUD's Desktop Users Guide for Submitting Electronic Grant Applications found at <http://www.hud.gov/offices/adm/grants> and submission information contained in this notice.

c. Submission Tips.

(1) *Delayed Transmission Time.* Applicants using dial-up connections should be aware that transmitting your application takes extra time before Grants.gov receives it. Grants.gov will provide either an error or a successfully received transmission message. The Grants.gov Help Desk reports that some applicants abort the transmission because they think that nothing is

occurring during the transmission process. Please be patient and give the system time to process the application. Uploading and transmitting a large file, particularly electronic forms with associated eXtensible mark-up language (XML) schema, will take considerable time to process and be received by Grants.gov. However, the upload even for large files should not take longer than one hour. If you are still waiting after one hour for the submission to be uploaded to Grants.gov, stop the transmission and check the available disk space and memory on your computer or check to see if you followed the submission requirements, including naming of files, and that you are using compatible versions of Adobe 8.1.3 with Adobe Professional on your computer operating system. HUD has found that difficulty in uploading an application from the applicant's desktop is most frequently due to: (a) Use of the wrong DUNS number or user name/password combination; (b) the application package being too large to be handled by the applicant's computer; (c) the applicant not downloading and setting the default settings to be compatible with the version of Adobe Reader downloaded; (d) the local entity's network limiting the size of files going in or out; (e) the Internet service provider having a file size limit (it often depends on the level of service contracted for); (f) the applicant's firewall is set to limit files going in or out, or access to certain Web sites; and (g) the applicant's anti-virus software or system set-up has placed other limits on accessing websites or file contents. HUD has found that if applicants, when uploading their applications, were first asked to permit access, it was usually because their firewall settings were preventing access to other websites, which resulted in submission failures. Applicants should check their firewall setting prior to beginning transmission to allow access to the Grants.gov portal. If you, the applicant, are experiencing long upload delays, or you receive a time-out error message, you should check your package for errors, anti-virus software, firewall, or Internet provider to be sure that there are no file size limits, and work with your IT support to address Internet, firewall, and anti-virus issues. In many instances, firewall and anti-virus protection can cause transmission problems and need to be disabled to permit a successful transmission. Applicants should also check their proxy and cache server configuration settings to ensure the application can be transmitted to

Grants.gov. Grants.gov uses HTTP post protocols on Port 80.

Please also ensure that file attachments are named in accord with the directions in this General Section. Be aware that multiple applications on a computer or very large files can overcome the processing power of a computer. If this is the case, you are advised to reduce the number and size of the attachment files by removing attachment files and submitting the attachments via the facsimile method, using the form HUD-96011 as the cover page, while the application without attachments should be uploaded to Grants.gov. HUD will match applications submitted to Grants.gov with facsimiles that have been transmitted following the directions in this notice. Do not split attachment files into two separate applications. HUD can only view the contents of a single application. For HUD to review the complete application, files must be transmitted with the application or associated with an application through use of the facsimile using the Facsimile Transmittal Cover Sheet (form HUD-96011). HUD will not match attachment files submitted either in two applications, or without using the cover sheet.

(2) *Using Task Manager to Monitor Processing.* Applicants experiencing long upload times or seeing a screen that states "Processing do not close," can check to see if the application is frozen or just taking awhile to upload by turning on the Task Manager to see if there is any processing occurring. To view the Task Manager, press Ctrl+Alt+Delete (by holding down Ctrl and Alt and then pressing Delete). A dialog box will appear; select Task Manager. There are four tabs across the top of the Task Manager. Select the Performance tab; then you will see two pairs of windows: CPU and Page file usage and usage history. The little windows on the right side (usage history) look like little graphs moving from right to left about one tick every second. As long as those graphs continue to move toward the left, you know your machine is not frozen. If the graph lines stop moving for more than a few seconds, your machine is totally frozen and you should immediately shut down the application, remove cookies, close down and reboot your computer, and then try to upload again.

(3) *Uploading Directly from Your Internet Browser.* If you have difficulty submitting the application, close down all applications, then reboot your computer and follow these steps:

(a) Open the Internet Explorer browser on your computer.

(b) Go to the File Menu and select "Open." This will cause the "Open" dialog box to appear.

(c) Click on the browse button, and another dialog box will appear with access to your files.

(d) In the dialog box, go to the drop-down menu for "File Types" and select "All Files."

(e) Through the dialog box, find the location of your saved application package (including the attachments).

(f) Once you have located your application package, select it with your mouse and click the "Open" button. The dialog box will disappear and the "Open" dialog box will still be present.

(g) In the "Open" dialog box, click on the "OK" button. Your application package will now appear.

(h) Within your application package, to submit, click on the "Submit and Save" button.

(4) *Ensure You Have Installed the Free Grants.gov Software.* Check to ensure that the latest version of the Adobe Reader software available from Grants.gov, which is free for system users, has been properly installed on your computer. Applicants will find a link to the free software for download at the *Download Application* page for the funding opportunity available on Grants.gov. HUD has found that an improper installation or not using the recommended version of the Adobe Reader 8.1.3 software will result in an application not being able to upload properly. If you are not sure how to determine if the software is properly installed, call the Grants.gov Support Desk. If you are operating your computer through a network, contact your system administrator to download the latest software. Please allow sufficient time for your network system administrator to respond to your request.

5. *Adobe Reader Error Messages.*

The following are common error messages applicants may encounter while completing or uploading an Adobe Reader application package.

a. *An Error Message Occurred During File Transmission.*

This error message means that you are experiencing network connectivity issues or the network is slow. The file that you are attempting to upload is NOT being fully transmitted to Grants.gov. Grants.gov recommends that you check the Internet connection or contact your IT support staff to check your network connectivity and then try again. Please remember that often networks or Internet service providers have limits on the size of files transmitted. Often Internet service providers require an upgrade in service

to transmit larger files or unlimited size files. This may also be true for internal organizational networks.

b. *COS Parsing Exception at Position#####.*

If you receive this error message, the application package you submitted is corrupt and you have to resubmit a new application. Applicants are advised not to use data from the corrupt application to copy and paste into the new application because it is likely to corrupt the new application or cause transmission errors. Applicants should close and delete the corrupt file, download a new application package, open, complete the package manually and submit using a supported version of Adobe Reader. HUD also advises applicants that have attempted to upload the package through their browser to shut the browser and close all applications, delete any cookies, and then reboot before trying to resubmit.

c. *Error:*

org.xml.sax.SAXParseException:

In most cases this error indicates the form opened with software that is unsupported such as:

- An incompatible version of Adobe Acrobat Professional.
- An incompatible version of Adobe Reader (other than 8.1.3).
- Other Software.

In order to submit an Adobe Reader application package, you must have a compatible version of Adobe Reader. If you have received this error message it is recommended that you download a new application package then open, complete and submit it with the compatible version of Adobe Reader. If you collaborate on the application with others, please ensure that they have the compatible version of the Adobe Reader. If they have more than one version of the Adobe Reader on their computer advise them to either reset the default setting or remove the non-compatible version of Adobe Reader and replace it with the free Adobe Reader software from Grants.gov. HUD also advises applicants that have attempted to upload the package through their browser to shut the browser and close all applications, delete any cookies, and then reboot before trying to resubmit.

d. *File Damaged and Cannot Be Repaired.*

This error message means that your application package is corrupt. In order to successfully submit an application package, you will need to download a new application and resubmit. To avoid corruption you must use a compatible version of the Adobe Reader to view and complete the application.

e. *Incompatible version of Adobe.*

You will receive this error message if your application was opened with software other than a compatible version of Adobe Reader. Any and all edits made to an Adobe Reader application package must be made with a compatible version of Adobe Reader. Applications submitted with other than supported versions of Adobe Reader will not work with the Grants.gov system. The compatible version of Adobe Reader is available at the Grants.gov Web site at http://www.adobe.com/products/acrobat/readstep2_allversions.html.

f. *Schema Validation Error.*

In most cases this error message indicates the application package was opened at one point in time with an unsupported version of:

- Adobe Reader.
- Adobe Professional.
- Other Software.

You should download a new application package, open and complete the package manually and submit using a supported version of the Adobe Reader. You cannot use an existing corrupted package or data from the package to export and populate a new package because it is likely to corrupt the new package and/or cause submission errors.

g. *Intake Servlet is Unable to Save the Data.*

This is an error message that may occur during Grants.gov processing. Grants.gov will reprocess the application retaining the original submission dates and times. Processing may result in validation or rejection of the application. See information on reasons for rejection of an application. Applicants receiving the "Intake Servlet Unable to Save the Data" error message should check the status of their application by logging onto Grants.gov with their user name and password and checking the application status. If the status does not show the application received call the Grants.gov Help Desk.

h. *Broken Pipe.* If you receive the "Broken Pipe" message, this means that there were intermittent interruptions during submission. As a result the confirmation screen did not display properly after you submitted your application. If the "Broken Pipe" error message displays, you will not automatically receive a Grants.gov confirmation page and tracking number for your application. To ensure that your application package was received you have two options:

(1) Use the on-line "Track Application Status" feature on Grants.gov and view your submitted applications. If you do not see your

submitted application listed follow the instructions under item (b):

(2) Open the Internet browser window (example: Internet Explorer) and resubmit your application package as normal. If you still do not receive the confirmation page after you resubmit your application package, contact the Grants.gov Help Desk by calling 800-518-GRANTS or e-mailing Support@Grants.gov. HUD recommends calling the center for faster service.

i. *Error: Failed to Update Grant Application XML's LOB:Failed to Update Grant Application XML's LOB.* Grants.gov automatically reprocesses these applications. You should receive a receipt notification and either a rejection or validation notice following reprocessing. Applicants are advised to track the applications via the on-line "Track Application Status," the e-mail notifications or by calling the Grants.gov Help Desk. Reprocessed applications retain their original receipt times.

Grants.gov has also established a troubleshooting page for applicants at http://www.grants.gov/help/trouble_tips.jsp. Applicants are advised to be familiar with this page and pass on this information and the General Section instructions to any persons working on your application or charged with submitting the application on behalf of your organization.

D. *Intergovernmental Review/State Points of Contact (SPOC).* Executive Order 12372, "Intergovernmental Review of Federal Programs," was issued to foster intergovernmental partnership and strengthen federalism by relying on state and local processes for the coordination and review of federal financial assistance and direct development. HUD implementing regulations are published at 24 CFR part 52. The Executive Order allows each state to designate an entity to perform a state review function. Applicants can find the official listing of SPOCs for this review process at <http://www.whitehouse.gov/omb/grants/spoc.html>. States not listed on the Web site have chosen not to participate in the intergovernmental review process and, therefore, do not have a SPOC. If your state has a SPOC, you should contact the SPOC to see if it is interested in reviewing your application before you submit it to HUD.

Please make sure that you allow ample time for this review when developing and submitting your application. If your state does not have a SPOC, you can submit your application directly to HUD using Grants.gov.

E. *Funding Restrictions.* The individual program NOFAs will

describe any funding restrictions that apply to each program.

F. *Other Submission Requirements.*

1. *Discrepancies Between the Federal Register and Other Documents.* The Federal Register documents published by HUD are the official documents that HUD uses to solicit applications. Therefore, if there is a discrepancy between any materials published by HUD in its Federal Register publications and other information provided in paper copy, electronic copy, at <http://www.grants.gov>, or its Help Desk, or at HUD's Web site, the Federal Register publication prevails. Please be sure to review your application submission against the requirements in the Federal Register for the program NOFA or NOFAs to which you are applying. If you note discrepancies, please notify HUD immediately by calling the program contact listed in the NOFA, or the Office of Departmental Grants Management at 202-708-0667 (this is not a toll-free number).

2. *Application Certifications and Assurances.* Applicants are placed on notice that by signing (either through electronic submission or in paper copy submission, for those applicants granted a waiver to submit in paper) the SF-424 cover page:

a. The governing body of the applicant's organization has duly authorized the application for federal assistance. In addition, by signing or electronically submitting the application, the AOR certifies that the applicant:

(1) Has the legal authority to apply for federal assistance and has the institutional, managerial, and financial capacity (including funds to pay for any non-federal share of program costs) to plan, manage, and complete the program as described in the application;

(2) Will provide HUD with any additional information it may require; and

(3) Will administer the award in compliance with requirements identified and contained in the NOFA (General and Program Sections), as applicable to the program for which funds are awarded and in accordance with requirements applicable to the program.

b. No appropriated federal funds have been paid or will be paid, by or on behalf of the applicant, to any person for influencing or attempting to influence an officer or employee of any agency, a member of Congress, or an employee of a member of Congress, in connection with this application for federal assistance or any award of funds resulting from the submission of this application for federal assistance or its

extension, renewal, amendment, or modification. If funds other than federally appropriated funds have been or will be paid for influencing or attempting to influence the persons listed above, the applicant agrees to complete and submit the SF–LLL, Disclosure of Lobbying Activities, as part of its application submission package. The applicant further agrees to and certifies that it will require similar certification and disclosure of all subawards at all tiers, including subgrants and contracts.

c. Federally recognized Indian tribes and tribally designated housing entities (TDHEs) established by a federally recognized Indian tribe, as a result of the exercise of the tribe's sovereign power, are excluded from coverage by item b. (also known as the Byrd Amendment). However, state-recognized Indian tribes and TDHEs established under state law are not excluded from the statute's coverage and, therefore, must comply with item b. above.

By submitting an application, the applicant affirms its awareness of these certifications and assurances. The AOR submitting the application is affirming that these certifications and assurances are material representations of the facts upon which HUD will rely when making an award to the applicant. If it is later determined that the signatory to the application submission knowingly made a false certification or assurance or did not have the authority to make a legally binding commitment for the applicant, the applicant may be subject to criminal prosecution, and HUD may terminate the award to the applicant organization or pursue other available remedies.

3. *Waiver of Electronic Submission Requirements.* The regulatory framework for HUD's electronic submission requirement is the final rule established in 24 CFR 5.1005. Applicants seeking a waiver of the electronic submission requirement must request a waiver in accordance with 24 CFR 5.1005. HUD's regulations allow for a waiver of the electronic submission requirement for good cause. If the waiver is granted, the applicable program office's response will include instructions on how many copies of the paper application must be submitted, as well as how and where to submit them. Applicants that are granted a waiver of the electronic submission requirement will not be afforded additional time to submit their applications. The deadlines for applications will remain as provided in the program section of the NOFA. As a result, applicants seeking a waiver of the electronic application submission

requirement should submit their waiver request with sufficient time to allow HUD to process and respond to the request. Applicants should also allow themselves sufficient time to submit their application so that HUD receives the application by the established deadline date. For this reason, HUD strongly recommends that if an applicant finds it cannot submit its application electronically and must seek a waiver of the electronic grant submission requirement, it should submit the waiver request to the HUD program office designated in the applicable program NOFA no later than 15 days before the application deadline. To expedite the receipt and review of such requests, applicants may email their requests to the program contact listed in the program NOFA. If HUD does not have sufficient time to process the waiver request, a waiver will not be granted. Paper applications received without a prior approved waiver and/or after the established deadline date will not be considered. Applicants that submit a paper application with the wrong DUNS number will be provided the same one-day grace period to provide a corrected SF–424 to the location indicated in the waiver approval. Failure to meet the requirements will deem the application late and, as a result, the application will not be considered, rated, or ranked.

V. Application Review Information

A. Criteria

1. *Factors Used to Evaluate and Rate Applications.* For each program NOFA, the points awarded for the rating factors total 100, with a possibility of up to 2 bonus points, as specified below:

a. *RC/EZ/EC–II.* HUD will award two bonus points to each application that includes a valid form HUD–2990 certifying that the proposed activities/projects in the application are consistent with the strategic plan for an empowerment zone (EZ) designated by HUD or the U.S. Department of Agriculture (USDA), the tax incentive utilization plan for an urban or rural renewal community designated by HUD (RC), or the strategic plan for an enterprise community designated in round II by USDA (EC–II); and that the proposed activities/projects will be located within the RC/EZ/EC–II identified above and are intended to serve the residents. For ease of reference in this notice, all of the federally designated areas are collectively referred to as "RC/EZ/EC–IIs" and residents of any of these federally designated areas as "RC/EZ/EC–II residents." The individual funding

announcements will indicate if the bonus points are available under the program. This notice contains a certification that must be completed for the applicant to be considered for RC/EZ/EC–II bonus points. Applicants can obtain a list of RC/EZ/EC–IIs from HUD's grants Web page at <http://www.hud.gov/offices/adm/grants/fundsavail.cfm>. Applicants can determine if their program or project activities are located in one of these designated areas by using the locator on HUD's Web site at <http://egis.hud.gov/egis/>.

b. *The Five Standard Rating Factors for FY2009.* HUD has established the following five standard factors for awarding funds under the majority of its FY2009 program NOFAs. When providing information to HUD in response to Rating Factor 1, Capacity, applicants should not include Social Security Numbers on any resumes submitted to HUD.

Factor 1: Capacity of the Applicant and Relevant Organizational Staff.

Factor 2: Need/Extent of the Problem.

Factor 3: Soundness of Approach.

Factor 4: Leveraging Resources.

Factor 5: Achieving Results and Program Evaluation.

In FY2009, HUD is establishing standardized points for evaluating Logic Models submitted under Rating Factor 5, Achieving Results and Program Evaluation. The decision to standardize this rating factor resulted from review of submitted Logic Models and rating factor narrative statements, and training sessions held with HUD staff and the applicant community.

By standardizing the rating for the Logic Model submission, HUD believes that a greater understanding will be gained on the use and relationship of the Logic Model to information submitted as part of the Rating Factors for award. The standardization of the Logic Model submission in Rating Factor 5 highlights the relationship between the narratives produced in response to the factors for award, stated outputs and outcomes, and discrepancies or gaps that have been found to exist in submitted Logic Models. HUD also believes that the standardization will strengthen the use of the Logic Model as a management and evaluation tool.

The Logic Model is a tool that integrates program operations and program accountability. It links program operations (mission, need, intervention, projected results, and actual results), and program accountability (measurement tool, data source, and frequency of data collection and reporting, including personnel assigned

to function). Applicants/grantees should use it to support program planning, monitoring, evaluation, and other management functions.

HUD uses the Logic Model and its electronic version, the eLogic Model®, to capture an executive summary of the application submission in data format, which HUD uses to evaluate the attainment of stated applicant goals and anticipated results. HUD also uses the data for policy formulation.

HUD encourages applicants and those selected for award to use the Logic Model data to monitor and evaluate their own progress and effectiveness in meeting stated goals and achieving results consistent with the program purpose. To further this objective, and in response to grantee requests, for FY2009 HUD has added an additional column to the eLogic Model® that allows the grantee to input results achieved for the reporting period, as well as Year-To-Date (YTD) for each year of the award. This will allow the grantee to review performance each reporting period and for each year of the award “at a glance,” and without having to construct a report. For further information, see the Instructions in the FY2009 eLogic Model®, form HUD-96010. HUD’s goal is to measure the effectiveness of programs and ensure that housing, economic development programs, and services provided by HUD funds provide maximum benefit to low- and moderate-income persons in communities nationwide.

Factor 5, Achieving Results and Program Evaluation, will consist of 10 points for the Logic Model submission. Program areas can add up to an additional 5 points for responses to particular programmatic questions to be addressed as part of this factor. The matrix provided in Attachment 1 of this General Section identifies how the Logic Model will be rated in a standardized way across program areas. Training on the rating factor will be provided via satellite broadcast and archived on HUD’s Web site for repeat viewing.

Additional details about the five rating factors and the maximum points for each factor are provided in the program NOFAs. For a specific funding opportunity, HUD may modify these factors to take into account explicit program needs or statutory or regulatory limitations. Applicants should carefully read the factors for award as described in the program NOFA to which they are responding.

The Continuum of Care Homeless Assistance programs have only two factors that receive points: (1) Need and (2) Continuum of Care. Additional information will be available in the

Continuum of Care program NOFA to be published in the **Federal Register**.

c. *Additional Criteria: Past Performance.* In evaluating applications for funding, HUD will take into account an applicant’s past performance in managing funds, including, but not limited to, the ability to account for funds appropriately; timely use of funds received either from HUD or other federal, state, or local programs; timely submission and quality of reports to HUD; meeting program requirements; meeting performance targets as established in Logic Models approved as part of the grant agreement; timelines for completion of activities and receipt of promised matching or leveraged funds; and the number of persons to be served or targeted for assistance. HUD may consider information available from HUD’s records; the name check review; public sources such as newspapers, Inspector General or Government Accountability Office reports or findings; or hotline or other complaints that have been proven to have merit.

In evaluating past performance, HUD may elect to deduct points from the rating score or establish threshold levels as specified under the Factors for Award in the individual program NOFAs. Each program NOFA will specify how past performance will be rated.

B. *Reviews and Selection Process*

1. *HUD’s Strategic Goals to Implement HUD’s Strategic Framework and Demonstrate Results.* HUD is committed to ensuring that programs result in the achievement of HUD’s strategic mission. To support this effort, grant applications submitted for HUD programs will be rated on how well they tie proposed outcomes to HUD’s policy priorities and annual goals and objectives, as well as the quality of the applicant’s proposed evaluation and monitoring plans. HUD’s strategic framework establishes the following goals and objectives for the Department:

a. *Increase Homeownership Opportunities.*

- (1) Expand national homeownership opportunities.
- (2) Increase minority homeownership.
- (3) Make the home buying process less complicated and less expensive.
- (4) Reduce predatory lending through reform, education, and enforcement.
- (5) Help HUD-assisted renters become homeowners.
- (6) Keep existing homeowners from losing their homes.

b. *Promote Decent Affordable Housing.*

(1) Expand access to and the availability of decent, affordable rental housing.

(2) Improve the management accountability and physical quality of public and assisted housing.

(3) Improve housing opportunities for the elderly and persons with disabilities.

(4) Promote housing self-sufficiency.

(5) Facilitate more effective delivery of affordable housing by reforming public housing and the Housing Choice Voucher program.

c. *Strengthen Communities.*

(1) Assist disaster recovery in the Gulf Coast region.

(2) Enhance sustainability of communities by expanding economic opportunities.

(3) Foster a suitable living environment in communities by improving physical conditions and quality of life.

(4) End chronic homelessness and move homeless families and individuals to permanent housing.

(5) Address housing conditions that threaten health.

d. *Ensure Equal Opportunity in Housing.*

(1) Ensure access to a fair and effective administrative process to investigate and resolve complaints of discrimination.

(2) Improve public awareness of rights and responsibilities under fair housing laws.

(3) Improve housing accessibility for persons with disabilities.

(4) Ensure that HUD-funded entities comply with fair housing and other civil rights laws.

e. *Embrace High Standards of Ethics, Management, and Accountability.*

(1) Strategically manage human capital to increase employee satisfaction and improve HUD performance.

(2) Improve HUD’s management and internal controls to ensure program compliance and resolve audit issues.

(3) Improve accountability, service delivery, and customer service of HUD and its partners.

(4) Capitalize on modernized technology to improve the delivery of HUD’s core business functions.

f. *Promote Participation of Faith-Based and Other Community Organizations.*

(1) Reduce barriers to faith-based and other community organizations’ participation in HUD-sponsored programs.

(2) Conduct outreach and provide technical assistance to strengthen the capacity of faith-based and community organizations to attract partners and secure resources.

(3) Encourage partnerships between faith-based/other community organizations and HUD's grantees and subgrantees.

Additional information about HUD's Strategic Plan FY2006–FY2011, and 2002–2008 Annual Performance Plans is available at <http://www.hud.gov/offices/cfo/reports/cforept.cfm>.

2. *Policy Priorities.* HUD encourages applicants to undertake specific activities that will assist the Department in implementing its policy priorities and achieving its goals for FY2009 and beyond. Applicants that include work activities that specifically address one or more of these policy priorities will receive higher rating scores than applicants that do not address these HUD priorities. Each NOFA issued in FY2009 will specify which priorities relate to a particular program and how many points will be awarded for addressing those priorities.

a. *Improving the Knowledge of Homeowners, Homebuyers, and Renters to Be Aware of Discriminatory Practices in Real Estate and Lending; their Rights; and Increase Financial Literacy to Prevent Foreclosure to Address the Needs of Households Facing Foreclosure.*

Many households are currently at risk of losing their homes or are currently facing foreclosure procedures. Other households, particularly households composed of low- and moderate-income persons, persons with disabilities, the elderly, minorities, and persons with limited English proficiency are shut out of the housing market or face discriminatory lending or rental practices. HUD is interested in applicants undertaking the following types of activities to address the needs of these households such as:

(1) *Providing Credit Counseling and Education for Families and Individuals.*

- How to track spending and establishing a household budget;
- Managing credit cards and credit card debt;
- Understanding a credit report and how to improve credit scores;
- Establishing a savings plan and investment plan;
- How to prevent foreclosure;
- Understanding the foreclosure process and options open to homeowners;
- Buying a foreclosed home—opportunities and risks.

(2) *Homebuying Information for New Homeowners.*

- Buying a new home;
- Buying an FHA Real Estate Owned Property;
- Buying a foreclosed property;
- Understanding loan alternatives;

- Understanding FHA mortgages and options;

- Financial ability to repay a loan;
- Accounting for additional expenses;
- Understanding the appraisal

process;

- Understanding a home inspection process and report;

- Understanding predatory lending practices; and

- Understanding your rights under the Fair Housing Act and fair lending practices;

(3) *Rental Housing Options.*

- Understanding lease agreements;
- Understanding landlord tenant rights and responsibilities;

- Understanding lending discrimination; and

- Understanding discriminatory rental practices and where to seek assistance;

(4) How to file a housing discrimination complaint.

(5) Complying with Limited English Proficiency requirements.

(6) Addressing the needs of homeowners, homebuyers, and renters who are persons with disabilities;

- How to design informational literature and presentations for persons with disabilities,

- Understanding accessible design and visibility standards for educating architects, builders, local, and state officials to increase the housing choices for persons with Limited English Proficiency or persons with disabilities;

- Understanding how to market to persons with disabilities; and

- Educating persons with disabilities on Uniform Accessibility Standards (UFAS), which apply to section 504 of the Rehabilitation Act of 1973.

Applicants seeking a policy priority point must identify the specific activities to be undertaken and the expected outcomes to be achieved as a result of the activities. The outcomes must be expressed in terms of the numbers of households assisted that either obtained rental housing or achieved homeownership; were able to improve their credit score or prevent foreclosure; were able to retain their home after having received a notice of foreclosure; were able to obtain a mortgage loan or reduce the rate or the amount owed on their mortgage; were able to find affordable rental housing that is accessible and visitable; or reported and/or filed a Fair Housing complaint. Copies of the UFAS are available online at <http://www.access-board.gov/ufas/ufas-html/ufas.htm>. The design and construction requirements for covered multifamily dwelling units that are applicable to the Fair Housing Act are found at <http://>

www.fairhousingfirst.org and select “Design or Construction Requirements.”

Proposed activities support strategic goals a, b, and d.

b. *Encouraging Accessible Design Features.* As described in section III.C.2.c., applicants must comply with applicable civil rights laws, including the Fair Housing Act, section 504 of the Rehabilitation Act of 1973, and the Americans with Disabilities Act. These laws and regulations implementing them prohibit discrimination based on disability and require recipients to ensure that assisted housing, facilities, programs, and activities are accessible to persons with disabilities, including meeting accessibility design standards. HUD is encouraging applicants to add accessible design features beyond those required under civil rights laws and regulations. Such features would eliminate barriers not addressed by design standards that limit the access of persons with disabilities to housing and other facilities. Copies of the UFAS are available online at <http://www.access-board.gov/ufas/ufas-html/ufas.htm>; from the NOFA Information Center at 800–HUD–8929 (toll free); and from the Office of Fair Housing and Equal Opportunity, Department of Housing and Urban Development, 451 Seventh Street, SW., Room 5240, Washington, DC 20410–2000; telephone number 202–708–2333 (this is not a toll-free number). Persons with hearing or speech impairments may access these numbers via TTY by calling the Federal Information Relay Service at 800–877–8339. (This is a toll-free number.)

Accessible design features are intended to promote visitability and incorporate features of universal design, as described below.

(1) *Visitability in New Construction and Substantial Rehabilitation.*

Applicants are encouraged to incorporate visitability features, where feasible, in new construction and substantial rehabilitation projects. Visitability features allow a person with mobility impairments access into the home, even if such features are not required by accessibility standards. Applicants should be aware of any locally adopted visitability standards. Generally, visitability standards or guidelines do not require that all features of a housing or other facility be made accessible to a person with a disability. Visitability means that there is at least one entrance at grade (no steps), approached by an accessible route such as a sidewalk, and that the entrance door and all interior passage doors are at least 2 feet, 10 inches wide, allowing 32 inches of clear passage space. A visitable home also serves

persons without disabilities, such as a mother pushing a stroller or a person delivering a large appliance. More information about visitability is available at <http://www.concretechange.org/>.

Activities support strategic goals b, c, and d.

(2) *Universal Design.* Applicants are encouraged to incorporate universal design in the construction or rehabilitation of housing, retail establishments, and community facilities funded with HUD assistance. Universal design is the design of products and environments to be usable by all people to the greatest extent possible, without the need for adaptation or specialized design. The intent of universal design is to simplify life for everyone by making products, communications, and the built environment more usable by as many people as possible at little or no extra cost to the user. In addition to any applicable required accessibility feature under section 504 of the Rehabilitation Act of 1973 or the design and construction requirements of the Fair Housing Act, the Department encourages applicants to incorporate the principles of universal design when developing housing, community facilities, and electronic communication mechanisms, or when communicating with community residents at public meetings or events.

HUD believes that to address affordable housing needs effectively, it is necessary to provide affordable housing that is accessible to all regardless of ability or age. Likewise, creating places where people work, train, and interact that are usable and open to all residents increases opportunities for economic and personal self-sufficiency. More information on universal design is available from the Center for Universal Design at <http://www.design.ncsu.edu/cud/> or the Resource Center on Accessible Housing and Universal Design at <http://www.abledata.com/abledata.cfm?pageid=113573&top=16029§ionid=19326>.

To obtain the policy priority point, applicants must identify the proposed number of units or facilities which will be provided that incorporate Universal Design and/or Visitability Features, including what features are planned for inclusion in the design and for how many units. Individual NOFAs will identify the minimum number of units or community facility areas that must comply with this requirement to receive the policy priority point. Selected applicants will be required to report on an annual basis the number of units that

were completed according to the plan; and the actual number of households that were placed in the units, including the square footage of units or public facilities or common areas. Applicants must identify visitability features that will be part of their program of activities and its projected results, including linear feet of sidewalk, walkway, or other areas that were created or modified to enhance visitability or meet locally adopted visitability requirements.

Activities support strategic goals a through d.

c. Providing Full and Equal Access to Grassroots Faith-Based and Other Community Organizations in HUD Program Implementation.

(1) HUD encourages applicants to partner with nonprofit organizations, including grassroots faith-based and other community organizations, in the implementation of the vast array of programs for which funding is available through HUD's competitive programs. Grassroots organizations have a strong history of providing vital community services. Additionally, HUD encourages applicants to include grassroots faith-based and other community organizations in their work plans. Applicants who identify at least 15 percent of the total work activities to be conducted will be performed by grassroots nonprofit organizations, including faith-based and community-based organizations in their program work statement and implementation activities, will be eligible to receive the policy priority point.

(2) *Definitions of Grassroots Organizations.*

(a) HUD will consider an organization a "grassroots organization" if the organization is headquartered in the local community in which it provides services; and

(i) Has a social services budget of \$300,000 or less, or

(ii) Has six or fewer full-time equivalent employees.

(b) Local affiliates of national organizations are not considered "grassroots." Local affiliates of national organizations are encouraged, however, to partner with grassroots organizations, but must demonstrate that they are currently working with a grassroots organization (e.g., having a grassroots faith-based or other community organization provide volunteers).

(c) The cap provided in paragraph (2)(a)(i) above includes only that portion of an organization's budget allocated to providing social services. It does not include other portions of the budget, such as salaries and expenses, not

directly expended in the provision of social services.

Applicants will be required to identify and describe in detail the work activities to be performed by the grassroots organizations including projected outputs and outcomes in their application for assistance. Selected applicants for funding will be required to report in accordance with the reporting requirements for the program, the results achieved against the projected outputs and outcomes.

Activities support strategic goal f.

d. Participation of Minority-Serving Institutions (MSIs) in HUD Programs.

Pursuant to Executive Orders 13256, "President's Board of Advisors on Historically Black Colleges and Universities;" 13230, "President's Advisory Commission on Educational Excellence for Hispanic Americans;" 13216, "Increasing Participation of Asian Americans and Pacific Islanders in Federal Programs;" and 13270, "Tribal Colleges and Universities," HUD is strongly committed to broadening the participation of MSIs in its programs. HUD is interested in increasing the participation of MSIs in providing assistance to New Orleans and other communities that suffer from the long-term and devastating effects of presidentially-declared disasters which are currently listed as active on the Federal Emergency Management Agency's (FEMA) Web site. To receive the policy priority point, the applicant must include a listing of the proposed work activities to be performed by the MSI; the specific sites where the work will be performed; and the projected output and outcome of the work to be performed that will result in a physical, social, or economic change in the community being assisted as a result of the work activities. MSIs that receive direct HUD funding are not eligible to receive the policy priority point unless they can demonstrate that their work activities are targeted to disaster areas and not just areas surrounding their campus, unless it is a city or community that experienced a declared and active disaster determined by the President. A listing of MSIs can be found on the Department of Education Web site at <http://www.ed.gov/about/offices/list/ocr/edlite-minorityinst.html> or HUD's Web site at <http://www.hud.gov/offices/adm/grants/fundsavail.cfm>. A listing of presidentially declared disasters can be found at http://www.fema.gov/news/disaster_totals_annual.fema.

Activities support strategic goals c and d.

e. Ending Chronic Homelessness.

President Bush has set a national goal to end chronic homelessness. HUD

Secretary Steven Preston has embraced this goal and has pledged that HUD's grant programs will be used to support the President's goal and better meet the needs of chronically homeless individuals. A person experiencing chronic homelessness is defined as an unaccompanied individual with a disabling condition who has been continuously homeless for a year or more or has experienced four or more episodes of homelessness over the last 3 years. A disabling condition is defined as a diagnosable substance abuse disorder, serious mental illness, developmental disability, or chronic physical illness or disability, including the co-occurrence of two or more of these conditions. Applicants are encouraged to target assistance to chronically homeless persons by undertaking activities that will result in:

(1) Creation of affordable housing units, supportive housing, and group homes;

(2) Establishment of a set-aside of units of affordable housing for the chronically homeless;

(3) Establishment of substance abuse treatment programs targeted to the homeless population;

(4) Establishment of job training programs that will provide opportunities for economic self-sufficiency;

(5) Establishment of counseling programs that assist homeless persons in finding housing, managing finances, managing anger, and building interpersonal relationships;

(6) Provision of supportive services, such as health care assistance, that will permit homeless individuals to become productive members of society; and

(7) Provision of service coordinators or one-stop assistance centers that will ensure that chronically homeless persons have access to housing assistance and a variety of social services.

Applicants that are developing programs to meet the goals set in this policy priority should keep in mind the requirements of the regulations implementing Section 504 of the Rehabilitation Act, in particular, 24 CFR 8.4(b)(1)(iv), 8.4(c)(1), and 8.4(d).

To receive the policy priority point, applicants must coordinate with the local Continuum of Care lead agency and propose work activities to fill the need already established by the local Continuum of Care. Applicants must include supporting documentation from the local Continuum of Care or member agency in their application and include specific tasks and projected outputs and outcomes. If selected for funding, applicants must compare the actual

results against projected outcomes in accordance with the program NOFA reporting periods contained in the program NOFA.

Activities support strategic goals b and c.

f. *Promoting Energy Star and Green Development.* HUD is encouraging grantees to take specific energy-saving actions in furtherance of HUD's Energy Action Plan described in the August 2006 Report to Congress entitled: "Promoting Energy Efficiency at HUD in a Time of Change," submitted under section 154 of the Energy Policy Act of 2005 (Pub. L. 109-58). (A copy of the report can be obtained at <http://www.huduser.org/publications/destech/energyefficiency.html>.) Under this policy priority, HUD is providing up to two policy priority points, as follows:

(1) Applicants/grantees that design, build, rehabilitate, or operate housing or community facilities.

(a) *Energy Star Appliances and Products.* Grantees that design, build, or operate housing or community facilities with funds awarded through HUD's NOFAs will receive one policy priority point if they incorporate energy-efficiency measures in the design, construction, and operation of these properties. To receive a point, grantees must meet the following criteria:

- *Moderate rehabilitation and/or Building Operation and Maintenance:* Use Energy Star-labeled appliances and products.

- *New construction or substantial rehabilitation (single family):* All units must be certified by a Home Energy Rater as an Energy Star Qualified Home; and all appliances must be Energy Star qualified.

- *New construction or substantial rehabilitation (multifamily):* Meet ASHRAE 90.1-2007 plus 20 percent (Appendix G) and appliances must be Energy Star qualified. A heat load analysis showing compliance with this standard must be completed by the project architect or engineer during the design phase of the project.

- *Housing Counseling:* Provide training on energy costs and budgeting, as well as energy efficient products and appliances, including Energy Star, in counseling curriculum.

(b) *Green Development.* HUD is also interested in promoting green building. Therefore, applicants that demonstrate they will undertake green development in the implementation of their program are eligible to receive one additional policy priority point for green development. This additional policy priority point for green development is available only to applicants that fulfill the requirements for use of Energy Star

appliances and products above, plus undertake green development.

Green development means that one of several recognized green rating programs, including: the Energy Star Plus Indoor Air Package or Energy Star Advanced New Home Construction; Earthcraft; Enterprise Green Communities Initiative; the National Association of Home Builders (NAHB) Green Building Guidelines; Leadership in Energy and Environmental Design (LEED) for Homes (for single family); and LEED New Construction (for multifamily) is used in the design and construction of properties. For green programs that require third-party certification, the applicant must provide evidence of such certification. For green programs that require self-certification, the applicant must provide evidence of self-certification, such as the Enterprise Green Communities checklist.

Applicants that elect to meet the requirements for Green Development will receive one policy priority point.

Applicants electing to meet these requirements must agree to use the HUD/PIH Benchmarking Tool at <http://www.hud.gov/offices/pih/programs/ph/phecc/econserve.cfm> to enter utility data for the first year after building occupancy, and report the results to HUD. The building would be expected to achieve a score of at least 65 (15 percent over average). For information on Energy Star Qualified Homes and Energy Star qualified products, see <http://www.energystar.gov>.

(2) Applicants/grantees that provide housing counseling, housing counseling training or community development technical assistance.

(a) *Energy Star Appliances and Products.* Applicants/grantees that receive funds for HUD's Housing Counseling, Housing Counseling Training, and Community Development Technical Assistance programs will receive policy priority points if, when providing counseling or training services or technical assistance, they include information on Energy Star appliances and products and information on the potential cost savings associated with buildings constructed using Energy Star standards.

(b) *Green Development.* Applicants/grantees that receive funds for HUD's Housing Counseling, Housing Counseling Training, and Community Development Technical Assistance programs will receive one additional policy priority point if, when providing counseling or training services or technical assistance, they provide information on Green Design, Development, and Certification

Standards in addition to the Energy Star information in the preceding paragraph.

Activities support strategic goals a and b.

g. Promoting Assistance to Veterans.

HUD is interested in applicants who incorporate assistance to veterans in the development and implementation of their proposed program of activities. HUD will provide a policy priority point to applicants that provide assistance to veterans in their transition from military service to civilian life, by addressing veterans' needs for housing, community-based services, or job training and employment opportunities. To receive the policy priority point, applicants will have to identify specific activities that are targeted to veterans; the housing, community development, or economic development need being addressed; the number of veterans anticipated to be assisted; and the anticipated outcome that will result from the services provided. Applicants must provide projected number of veterans to be directly assisted, and the actual number of veterans receiving the assistance and what were the results of the services delivered in terms of the number of veterans provided housing, job training, jobs acquired, or social services received. Applicants selected for funding must compare actual results against projected outcomes in accordance with the program NOFA reporting periods contained in the program NOFA.

Activities support strategic goals c and d.

3. Threshold Compliance. Only applications that meet all of the threshold requirements will be eligible to receive an award of funds from HUD.

4. Corrections to Deficient Applications. After the application deadline, and in accordance with the electronic submission grace period described in this notice, HUD may not, consistent with its regulations in 24 CFR part 4, subpart B, consider any unsolicited information that an applicant may want to provide. HUD may contact an applicant to clarify an item in its application or to correct curable (correctable) technical deficiencies. HUD may not seek clarification of items or responses that improve the substantive quality of an applicant's response to any rating factors. In order not to unreasonably exclude applications from being rated and ranked, HUD may contact applicants to ensure proper completion of the application, and will do so on a uniform basis for all applicants.

Examples of curable (correctable) technical deficiencies include inconsistencies in the funding request,

failure to submit the proper certifications, and failure to submit an application that contains a signature by an official able to make a legally binding commitment on behalf of the applicant. In the case of an applicant that received a waiver of the regulatory requirement to submit an electronic application, the technical deficiency may include failure to submit an application that contains an original signature. If HUD finds a curable deficiency in the application, HUD will notify the applicant in writing by describing the clarification or technical deficiency. HUD will notify applicants by e-mail, facsimile, or via the U.S. Postal Service, return receipt requested. Clarifications or corrections of technical deficiencies in accordance with the information provided by HUD must be submitted within 5 calendar days of the date of receipt of the HUD notification. (If the deadline date falls on a Saturday, Sunday, or federal holiday, the applicant's correction must be received by HUD on the next day that is not a Saturday, Sunday, or federal holiday.) In the case of electronic submissions to Grants.gov, any clarifications or cure items must be submitted electronically using the facsimile telephone number and form HUD-96011, Facsimile Cover Page, contained in the last application package submitted to HUD. The additional information will be matched to the electronic application in HUD's files. Applicants must follow the facsimile requirements found elsewhere in this notice. If the deficiency is not corrected within the above time frame, HUD will reject the application as incomplete, and it will not be considered for funding. In order to meet statutory deadlines for the obligation of funds or for timely completion of the review process, program NOFAs may reduce the number of days for submitting a response to a HUD request for clarification or correction to a technical deficiency. Please be sure to carefully read this notice and each program NOFA for any additional information and instructions. An applicant's response to a HUD notification of a curable deficiency should be submitted directly to HUD in accordance with the instructions provided in the notification.

5. Rating Panels. To review and rate applications, HUD may establish panels that may include persons not currently employed by HUD. HUD may include these non-HUD employees to obtain particular expertise and outside points of view, including views from other federal agencies. Persons brought into HUD to review applications are subject

to conflict-of-interest provisions. In addition, reviewers using HUD IT systems may be subject to an IT security check.

6. Rating. HUD will evaluate and rate all applications for funding that meet the threshold requirements.

7. Ranking. HUD will rank applicants within each program or, for Continuum of Care applicants, across the three programs identified in the Continuum of Care NOFA. HUD will rank applicants against only those applying for the same program funding.

Where there are set-asides within a program competition, the applicant will compete against only those applicants in the same set-aside competition.

C. Anticipated Announcement and Award Dates

The individual program NOFAs will provide the applicable information regarding this subject.

VI. Award Administration Information

A. Award Notices

1. Negotiation. After it has rated and ranked all applications and made selections, HUD may require, depending upon the program, that a selected applicant participate in negotiations to determine the specific terms of the funding agreement and budget. In cases where HUD cannot successfully conclude negotiations with a selected applicant or a selected applicant fails to provide HUD with requested information, an award will not be made to that applicant. In such an instance, HUD may offer an award to, and proceed with negotiations with, the next highest-ranking applicant.

2. Adjustments to Funding.

a. To ensure the fair distribution of funds and enable the purposes or requirements of a specific program to be met, HUD reserves the right to fund less than the full amount requested in an application.

b. HUD will not fund any portion of an application that: (1) Is not eligible for funding under specific HUD program statutory or regulatory requirements; (2) does not meet the requirements of this notice; or (3) is duplicative of other funded programs or activities from prior year awards or other selected applicants. Only the eligible portions of an application (excluding duplicative portions) may be funded.

c. If funds remain after funding the highest-ranking applications, HUD may fund all or part of the next highest-ranking application in a given program. If an applicant turns down an award offer, HUD will make an offer of funding to the next highest-ranking application.

d. If funds remain after all selections have been made, remaining funds may be made available within the current fiscal year for other competitions within the program area or be held over for future competitions.

e. If, subsequent to announcement of awards made under the FY2009 NOFAs, additional funds become available either through a supplemental appropriation or recapture of funds during FY2009, HUD reserves the right to use the additional funding to provide full funding to an FY2009 applicant that was denied the requested amount of funds due to insufficient funds to make the full award, and/or to fund additional applicants that were eligible to receive an award but for which there were no funds available.

f. Individual program NOFAs may have other requirements, so please review the program NOFAs carefully.

3. *Funding Errors.* In the event HUD commits an error that, if corrected, would result in selection of an applicant during the funding round of a program NOFA, HUD may select that applicant for funding, subject to the availability of funds.

4. *Performance and Compliance Actions of Funding Recipients.* HUD will measure and address the performance and compliance actions of funding recipients in accordance with the applicable standards and sanctions of their respective programs.

5. *Debriefing.* For a period of at least 120 days, beginning 30 days after the awards for assistance are publicly announced, HUD will provide to a requesting applicant a debriefing related to its application. A request for debriefing must be made in writing or by email by the authorized official whose signature appears on the SF-424 or by his or her successor in office, and be submitted to the person or organization identified as the contact under the section entitled "Agency Contact(s)" in the individual program NOFA under which the applicant applied for assistance. Information provided during a debriefing will include, at a minimum, the final score the applicant received for each rating factor, final evaluator comments for each rating factor, and the final assessment indicating the basis upon which assistance was provided or denied.

B. *Administrative and National Policy Requirements.* See Section III.C. of this notice regarding related requirements.

C. Reporting

1. *Use of a Logic Model to Report Performance.* In FY2004, HUD began using as a planning tool the Logic Model

submitted as part of NOFA applications. In FY2005, HUD required grant agreements to incorporate performance reporting against the approved Logic Model. In FY2006, HUD moved to standardized "master" Logic Models from which applicants can select needs, activities/outputs, and outcomes appropriate to their programs. In addition, program offices have identified Program Management Evaluation Questions that grantees will be required to report on, as specified in the approved program eLogic Model®. The time frame established for the Logic Model reporting will be in accordance with the program's established reporting periods and as stated in the program NOFA.

2. *Placement of Approved Logic Models and Reports on HUD's Web site.* It is HUD's intent to publish approved Logic Models and grantee progress reports submitted to HUD on its Grants Web site. Starting with awards made in FY2007, HUD established a Grants Performance page that features program performance ratings issued by OMB under its Program Assessment Rating Tool (PART) or its successor tool, for HUD programs that have been evaluated by OMB. HUD will also post all approved Logic Models that show each awardee's projected outputs and outcomes during the period of performance. As required performance reports are received by HUD, they will be added to the Web site. HUD is creating this Web site page to highlight and make available to the public performance and results from HUD-funded programs, in keeping with Executive Order 13392, issued December 14, 2005, and published in the **Federal Register** on December 19, 2005 (70 FR 75373). HUD believes that informing the public on progress is in keeping with presidential and congressional intent for transparency in federally funded programs, as demonstrated by the passage of the Federal Funding Accountability and Transparency Act of 2006 (Pub. L. 109-282), and creation of the federal Web sites <http://www.ExpectMore.gov> and <http://www.Results.gov>.

3. *Return on Investment Statements.* HUD also intends to propose Return on Investment (ROI) Statements for each of its competitive grant programs. Before finalizing ROI Statements for implementation, HUD will either offer incentive funding for applicants wishing to participate in developing an ROI as part of their grant program or HUD will publish the proposed ROI Statements for public comment. HUD believes the applicant/grantee community can greatly assist HUD in its

attempt to place a value on the work done under the Department's grant programs. While HUD expects grantees to respond to the Management Evaluation Questions in their final reports, reporting on the ROI Statements is not mandatory at this time. As HUD finalizes ROI Statements for each program, they will be included in awards in the future. In FY2008, HUD offered ROI incentive funding in the Housing for Persons with AIDS (HOPWA) NOFA.

4. *Logic Model Instructions.* The Logic Model form (HUD-96010), a Microsoft Excel workbook, contains instructions in Tab 1 on how to use the form. The form or eLogic Model® incorporates a program-specific master list of statements of need, service, or activity/output(s) and their associated unit(s) of measure; and outcome(s) and their associated unit(s) of measure. Applicants will be required to click on a cell within a column. When you click on the cell, the drop-down button appears to the right of the cell. Applicants can then select the appropriate statement(s) to reflect their proposed program. Applicants can select multiple need(s) and services, or activities/outputs and outcomes, but each selection is entered in separate cells using the drop-down menu. The unit measure, whether for outputs or outcomes, may be a number or date. Applicants insert the expected number of units to be completed or achieved or date of achievement during the period of performance. In this manner, the applicant will build a custom Logic Model reflecting their program of activities. The custom Logic Model will link the need(s) to the activity/output(s), which in turn are linked to the result or expected outcome(s) tailored to each of HUD's programs.

5. *Logic Model Format.* The following briefly describes the format for the HUD Logic Model. Full instructions are contained in the Logic Model found in the Instructions Download for the program, on Grants.gov. For the Logic Model to work properly, you must enable the macros upon opening the file.

a. Each Logic Model has drop-down menus for HUD Strategic Goals and Policy Priorities, to eliminate applicant confusion over what letters and numbers to use for the goals and priorities and to improve data quality.

b. Tabs for Year 1, Year 2, and Year 3 activities, as well as a tab for Total, are provided in each Logic Model. HUD found that applicants within a program had varying opinions or interpretations on time frames for short, intermediate, and long term and that the use of clearly

defined time frames eliminated the varying interpretations and provided for better quality data. In response to grantee requests, in FY2008, HUD added a column labeled YTD (Year-To-Date), which represents cumulative totals per year to each reporting period for results achieved. The column allows grantees to see immediately what they have achieved during the reporting period, what they have achieved as they progress throughout the year, what they have achieved on a cumulative basis each reporting year, and what they have achieved during the period of award. The total tab allows for cumulative projected and final results to be shown covering all years of the period of performance. Applicants with a one-year period of performance only have to complete the Year 1 tab, since the total results will all occur in the one-year award period. When reporting, be sure to show noncumulative data in the past column and cumulative data in the YTD column. In 2008, HUD also increased the number of rows in each Logic Model Worksheet to allow applicants to skip a row between groups of activities so they could better demonstrate the relationship between the activity(ies) and the expected outcomes.

c. For the grantees' convenience and to call attention to the requirements, the Logic Model form contains reporting instructions. The instructions ask

applicants to identify in their reports to HUD where actual results deviated from projected results—either positively or negatively. The Reporting Instruction tab includes a text field in which grantees can report any deviations, as well as their responses to the management questions. While the reporting tab does not add additional burden hours to the information collection, HUD believes that having the reporting tab in the form assists the applicant in completing their Logic Model and provides for better quality Logic Models and reporting to HUD. HUD will continue to review data received via eLogic Model® in 2008 and would like to thank the applicant/grantee community for their recommendations and insights.

In FY2009, HUD added fields for the applicant's DUNS number and project location. These data elements make it easier to place logic models on HUD's Web site and find application logic models by location. In FY2009, to provide for greater consistency in reporting, applicants must include all activities and outcomes expected each year of the period of performance. Applicants should carefully review the program NOFA for required outputs and outcome selections, because some of the program NOFAs define what must, at a minimum, be included in the Logic Model.

6. In FY2009, grantees must adhere to the following reporting principles:

a. An evaluation process will be part of the ongoing management of the HUD-funded award;

b. Comparisons will be made between projected and actual numbers for outputs and outcomes;

c. Deviations from projected outputs and outcomes will be documented and explained as part of required reporting; and

d. Data will be analyzed to determine the relationship of outputs to outcomes, to determine which outputs produce which outcomes and which are most effective.

As stated above, in FY2007, HUD required each program to establish a set of Program Management Evaluation Questions for grantee reporting. Grantees must use these questions to self-evaluate the management and performance of their program. HUD is continuing this practice in FY2009. In developing the Program Management Evaluation Questions for the Master Logic Model, HUD trained its program managers on the Carter-Richmond Methodology, a critical thinking process that identifies key management and evaluation questions for HUD's programs. The following table identifies the Carter-Richmond generic questions and where the source data is found in the Logic Model.

CARTER-RICHMOND METHODOLOGY: ¹ BUILDING BLOCKS FOR EFFECTIVE MANAGEMENT

Management questions	Logic model columns for source data
1. How many clients are you serving?	Service/Activity/Output.
2. How many units were provided?	Service/Activity/Output.
3. Who are you serving?	Service/Activity/Output.
4. What services do you provide?	Service/Activity/Output.
5. What does it cost?	Service/Activity/Output.
6. What does it cost per service delivered?	Service/Activity/Output/Evaluation.
7. What happens to the "subjects" as a result of the service? ²	Outcome.
8. What does it cost per outcome?	Outcome and Evaluation.
9. What is the value of the outcome?	Outcome and Evaluation.
10. What is the return on investment?	Evaluation.

¹"The Accountable Agency—How to Evaluate the Effectiveness of Public and Private Programs," Reginald Carter, ISBN Number 9780978724924.

²The subject can be a client or a unit, such as a building, and is defined in its associated unit of service.

²The subject can be a client or a unit, such as a building, and is defined in its associated unit of service.

As a result of this training, each program has developed specific Program Management Evaluation Questions tailored to the statutory purpose of each of their programs. Each program NOFA will require applicants to address these questions based upon the Carter-Richmond Methodology in their reports to HUD. The program NOFA Logic Models will identify the particular questions to be addressed that relate to the statutory purpose and intent of each program. In FY2008, the Management

Questions were developed as a Microsoft Excel table which formats the question as a data element and the response to the question as a data element. By creating this table, grantees when reporting can enter the response to the management questions in the data field provided, thus allowing the management question responses to be placed in the Logic Model database for further analysis.

Training on HUD's Logic Model and on the reporting requirements for

addressing the Program Management Evaluation Questions will be provided via satellite broadcast. The training will also provide examples of how to construct the Logic Model using the drop-down lists in the eLogic Model®. Training materials and the dates for the training will be on HUD's Web site at <http://www.hud.gov/offices/adm/grants/fundsavail.cfm>. In addition, each program NOFA broadcast will address the specific questions and reporting requirements for the specific program.

Applicants should submit the completed Logic Model as an attachment to their application, in accordance with the directions in the program NOFA for addressing the factors for award. Each program NOFA will identify if it requires the factors for award, including the Logic Model that is required as part of the application submission, to be submitted as a single attached file or as separate files. Please follow the program NOFA directions. When opening the eLogic Model® enable the Macros. Do not convert the file to PDF format. Save the file in the format you opened it. Grants.gov can now accept Microsoft Office 2007 files and HUD can read both Microsoft Office 2003 and Microsoft Office 2007 files.

After being selected for funding and awarded funds, grantees will be required to submit a completed form HUD-96010, Logic Model, indicating results achieved against the proposed output(s) and proposed outcome(s) stated in the grantee's approved application and agreed to by HUD. The Logic Model and required management questions must be submitted to HUD in accordance with the reporting periods identified in each program NOFA for providing reports to HUD.

7. *Use of Form HUD-27061, Race and Ethnic Data Reporting Form, to Report Race and Ethnicity Data for Beneficiaries of HUD Programs.* HUD requires grantees that provide HUD program benefits to individuals or families to report data on the race and ethnicity of those receiving such benefits. Grantees that provide benefits to individuals during the period of performance, whether directly, through subrecipients, or through contractual arrangements, must report the data using form HUD-27061, Race and Ethnic Data Reporting Form, on Grants.gov. The form is a data collection based on the standards published by OMB on August 13, 2002. The individual program NOFAs will identify applicable reporting requirements related to each program. Applicants reporting to HUD using an online system can use that system to meet this requirement, provided that the data elements and reports derived from the system are equivalent to the data collection in the form HUD-27061. For programs where race and ethnicity reporting is required, copies of form HUD-27061 will be included in the Instructions Download portion of the application posted to Grants.gov.

8. *Frequency of Reports and Data Consistency.*

a. *Logic Model Reporting.* When submitting eLogic Model® reports on a quarterly, semiannual, or annual basis,

each report should show the results that occurred during that reporting period. All final reports should provide a final eLogic Model® performance for the entire period of the award. See instructions in the eLogic Model® on how to label files when reporting. When reporting, be sure to show noncumulative data in the past column and cumulative data in the YTD column.

b. *Race and Ethnic Data Report.* When submitting the Race and Ethnic Data Reporting Form (HUD-27061) on a quarterly or semiannual basis, each reporting period should show the results that occurred during the performance period for all active clients. If a multiyear program is funded, then each annual report should show results that occurred during that performance year for all active clients. A final form HUD-27061 should show results for all active clients for the entire period of performance.

VII. Agency Contact(s)

The individual program NOFAs will identify the applicable agency contacts related to each program. Questions regarding this notice should be directed to the NOFA Information Center between the hours of 10 a.m. and 6:30 p.m. eastern time at 800-HUD-8929. Persons with hearing or speech impairments may access this number via TTY by calling the Federal Information Relay Service at 800-877-8339. (These are toll-free numbers.) Questions regarding specific program requirements should be directed to the agency contacts identified in each program NOFA.

VIII. Other Information

A. *Public Law 106-107, Streamlining Activities and Grants.gov.* The Federal Financial Assistance Management Improvement Act of 1999 (Pub. L. 106-107) directed each federal agency to develop and implement a plan that, among other things, streamlines and simplifies the application, administrative, and reporting procedures for federal financial assistance programs administered by the agency. This law also required the Director of OMB to direct, coordinate, and assist federal agencies in establishing: (1) A common application and reporting system and (2) an interagency process for addressing ways to streamline and simplify federal financial assistance application and administrative procedures, as well as reporting requirements for program applicants. Over the last several years, the intergovernmental work groups tasked with the implementation of

Public Law 106-107 have been engaged in various streamlining activities that are now being shared with the grantee community for their input prior to being implemented across the federal government. Public Law 106-107 sunset in 2008. Despite the sunset of the law, federal agencies are still working to simplify and streamline their application and submission requirements. Applicants and grantees are urged to participate in the broadcasts sponsored by the Grants Policy Committee and the federal government work groups to become familiar with the proposed changes to simplify requirements, at <http://www.gpc.gov>.

B. *Grants.gov.* The Grants.gov initiative focuses on allowing the public to easily FIND competitive funding opportunities and then APPLY for grant funding electronically via Grants.gov. In FY2004, HUD posted all of its funding opportunities, with the exception of Continuum of Care, at http://www.grants.gov/applicants/find_grant_opportunities.jsp and has continued to do so through FY2009. In addition, Grants.gov is working with federal agencies to begin the process of accepting mandatory and formula grant program plans and application submissions online via Grants.gov. Applicants for HUD's formula and competitive programs are urged to become familiar with the Grants.gov website, registration procedures, and electronic submissions so that, as the website is expanded, applicants will be registered and familiar with the find-and-apply functionality. The Grants.gov Internet address for Finding Grant Opportunities is http://www.grants.gov/applicants/find_grant_opportunities.jsp. The Grants.gov Internet address for Applying for Grant Opportunities is http://www07.grants.gov/applicants/apply_for_grants.jsp.

C. *HUD-IRS Memorandum of Agreement.* HUD and the IRS have entered into a memorandum of agreement to provide information to HUD grantees serving low-income, disabled, and elderly persons, as well as persons with limited English proficiency, on the availability of low-income housing tax credits, the earned income tax credit, individual development accounts, child tax credits, and the IRS Voluntary Income Tax Assistance program. HUD is making available on its website information on these IRS asset-building resources. HUD encourages you to visit the website and disseminate this information to low-income residents in your community and other organizations that serve low-income residents, so that eligible

individuals can take advantage of these resources.

D. Paperwork Reduction Act Statement. The information collection requirements in this notice have been approved by OMB under the Paperwork Reduction Act of 1995 (44 U.S.C. 3501–3520). In accordance with the Paperwork Reduction Act, HUD may not conduct or sponsor, and a person is not required to respond to, a collection of information, unless the collection displays a valid OMB control number. Each program NOFA will identify its applicable OMB control number.

E. Environmental Impact. A Finding of No Significant Impact with respect to the environment has been made for this notice, in accordance with HUD regulations at 24 CFR part 50 that implement Section 102(2)(C) of the National Environmental Policy Act of 1969 (42 U.S.C. 4332(2)(C)). As program NOFAs are issued, each will provide a statement regarding Environmental Impact. The Finding of No Significant Impact for this notice is available for public inspection between 8 a.m. and 5 p.m. eastern time, Monday through Friday, except federal holidays, in the Office of General Counsel, Regulations Division, Department of Housing and Urban Development, 451 7th Street, SW., Room 10276, Washington, DC 20410–0500.

F. Executive Orders and Congressional Intent

1. Executive Order 13132, Federalism. Executive Order 13132 prohibits, to the extent practicable and permitted by law, an agency from promulgating policies that have federalism implications and either impose substantial direct compliance costs on state and local governments and are not required by statute, or preempt state law, unless the relevant requirements of Section 6 of the executive order are met. This notice does not have federalism implications and does not impose substantial direct compliance costs on state and local governments or preempt state law within the meaning of the executive order.

2. American-made Products. Sections 708 and 709 of the Transportation, Treasury, Housing and Urban Development, the Judiciary, and Independent Agencies Appropriations Act, 2006 (Pub. L. 109–115; approved Nov. 30, 2005), states that, to the greatest extent practicable, all equipment and products purchased with funds made available should be made in the United States.

3. Eminent Domain. In accordance with Division K, Title IV (General Provisions), Section 411 of the

Consolidated Appropriations Act, 2008 (Pub. L. 110–161, approved December 26, 2007), no funds made available in FY2008 may be used to support any federal, state, or local projects that seek to use the power of eminent domain, unless eminent domain is employed only for a public use. This limitation also applied to FY2007 appropriated funds. In FY2009, this limitation may apply, subject to the language in HUD's final approved appropriation act.

Based upon language in previous appropriations, for purposes of this provision, public use shall not be construed to include economic development that primarily benefits private entities.

Further, any use of funds for mass transit, railroad, airport, seaport, or highway projects, as well as utility projects which benefit or serve the general public (including energy-related, communication-related, water-related, and wastewater-related infrastructure), other structures designated for use by the general public or which have other common-carrier or public-utility functions that serve the general public and are subject to regulation and oversight by the government, and projects for the removal of an immediate threat to public health and safety or brownfields, as defined in the Small Business Liability Relief and Brownfields Revitalization Act (Pub. L. 107–118), shall be considered a public use for purposes of eminent domain.

G. Public Access, Documentation, and Disclosure. Section 102 of the Department of Housing and Urban Development Reform Act of 1989 (HUD Reform Act) (42 U.S.C. 3545) and the regulations codified at 24 CFR part 4, subpart A, contain a number of provisions that are designed to ensure greater accountability and integrity in the provision of certain types of assistance administered by HUD. On January 14, 1992, HUD published a notice that also provides information on the implementation of section 102 (57 FR 1942). The documentation, public access, and disclosure requirements of section 102 apply to assistance awarded under individual NOFAs published as described below.

1. Documentation, Public Access, and Disclosure Requirements. HUD will ensure that documentation and other information regarding each application submitted pursuant to its FY2009 NOFAs are sufficient to indicate the basis upon which assistance was provided or denied. This material, including any letters of support, will be made available for public inspection for a 5-year period beginning not less than

30 days after the award of the assistance. Material will be made available in accordance with the Freedom of Information Act (5 U.S.C. 552) and HUD's implementing regulations (24 CFR part 15).

2. Form HUD–2880, “Applicant/Recipient Disclosure/Update Report” (“HUD Applicant Recipient Disclosure Report” on Grants.gov). HUD will also make available to the public, for 5 years, all applicant disclosure reports (form HUD–2880) submitted in connection with an FY2009 NOFA. Update reports (also reported on form HUD–2880) will be made available along with the applicant disclosure reports, but in no case for a period of less than 3 years. All reports, both applicant disclosures and updates, will be made available in accordance with the Freedom of Information Act (5 U.S.C. 552) and HUD's implementing regulations (24 CFR part 5).

3. Publication of Recipients of HUD Funding. HUD's regulations at 24 CFR part 4 provide that HUD will publish a notice in the **Federal Register** to notify the public of all funding decisions made by the Department to provide:

- a. Assistance subject to Section 102(a) of the HUD Reform Act; and
- b. Assistance provided through grants or cooperative agreements on a discretionary (non-formula, non-demand) noncompetitive basis.

H. Section 103 of the HUD Reform Act. HUD's regulations implementing section 103 of the HUD Reform Act, codified at 24 CFR part 4, subpart B, apply to this funding competition. The regulations continue to apply until the announcement of the selection of successful applicants.

HUD employees involved in the review of applications and in the making of funding decisions are prohibited by the regulations from providing advance information to any person (other than an authorized employee of HUD) concerning funding decisions or from otherwise giving any applicant an unfair competitive advantage. Persons who apply for assistance should confine their inquiries to the subject areas permitted under 24 CFR part 4.

Applicants or employees who have ethics-related questions should contact the HUD Ethics Law Division at 202–708–3815 (this is not a toll-free number). The toll-free TTY number for persons with speech or hearing impairments is 800–877–8339. HUD employees who have specific program questions should contact the appropriate field office counsel or

Headquarters counsel for the program to which the question pertains.

BILLING CODE 4210-67-P

APPENDIX A

Funding Opportunity Programs Anticipated to Be Available in FY2009

Program	Estimated Time for NOFA Publication
Indian Community Development Block Grant Program	January 2009-February 2009
Healthy Homes Technical Studies	January 2009-February 2009
Housing Counseling	January 2009-February 2009
Housing Counseling Training	January 2009-February 2009
Lead Hazard Control NOFA: Lead-Based Paint Hazard Control Grant Program; Lead Hazard Reduction Demonstration Program	January 2009-February 2009
Rural Housing and Economic Development (RHED)	January 2009-February 2009
Assisted Living Conversion Program (ALCP)	January 2009-March 2009
Brownfields Economic Development Initiative (BEDI)	January 2009-March 2009
Capacity Building Grants (<i>limited eligibility</i>)	January 2009-March 2009
Community Development Technical Assistance (CDTA)	January 2009-March 2009
Fair Housing Initiatives Program (FHIP)	January 2009-March 2009
HOPE VI Main Street	January 2009-March 2009
Housing Choice Voucher Family Self-Sufficiency (HCV-FSS) Program Coordinators	January 2009-March 2009
Housing Opportunities for Persons with AIDS (HOPWA)	January 2009 - March 2009

APPENDIX A

Funding Opportunity Programs Anticipated to Be Available in FY2009

Public and Indian Housing Family Self-Sufficiency under ROSS	January 2009 - March 2009
Self-Help Homeownership Opportunity Program (SHOP)	January 2009 - March 2009
Early Doctoral Dissertation/Doctoral Research Dissertation	February 2009 - April 2009
Green and Healthy Housing Technical Studies	February 2009 - April 2009
Healthy Homes Demonstration	February 2009 - April 2009
HOPE VI Revitalization	February 2009 - April 2009
Section 202 Supportive Housing for the Elderly	February 2009 - April 2009
Section 811 Supportive Housing for Persons with Disabilities	February 2009 - April 2009
Alaskan Native/Native Hawaiian Institutions Assisting Communities	March 2009 - May 2009
Hispanic Serving Institutions Assisting Communities (HSIAC)	March 2009 - May 2009
Historically Black Colleges and Universities (HBCU) Program	March 2009 - May 2009
Resident Opportunity and Self-Sufficiency (ROSS) – Service Coordinators Program	March 2009 - May 2009
Section 202 Demonstration Pre-Development Grant Program (DPG)	March 2009 - May 2009
Tribal Colleges and Universities Program (TCUP)	March 2009 - May 2009
Continuum of Care	May 2009 – June 2009

Appendix B

Logic Model Assessment Matrix

Logic Model Assessment Matrix – Selection of Services/Activities and Outcomes and Projections				
	Excellent	Good	Marginally Satisfactory	Unacceptable
Services	Applicant <u>selected</u> services/activities from the drop down list that are consistent with both the NOFA and the Narrative.	Applicant's Narrative identified services/activities consistent with the NOFA, but the drop down list <u>does not</u> contain that service/activity.	Applicant <u>selected</u> services/activities from the drop down list that are inconsistent with the Narrative, <i>or</i> did not select available services/activities from the drop down list that are consistent with the Narrative, <i>or</i> provided Narrative that is inconsistent with the NOFA.	Applicant <u>did not</u> select available services/activities from the drop down list that are consistent with the Narrative, <i>and</i> either the Logic Model is inconsistent with the Narrative <i>or</i> the Narrative is inconsistent with the NOFA.
	3 points	2 points	1 point	0 points
Outcomes	Applicant <u>selected</u> an outcome from the drop down list that is consistent with both the NOFA and the Narrative.	Applicant's Narrative identified an outcome consistent with the NOFA, but the drop down list does not contain that outcome.	Applicant <u>selected</u> an outcome from the drop down list that is inconsistent with the Narrative, <i>or</i> did not select an available outcome from the drop down list that is consistent with the Narrative.	Applicant <u>did not</u> select an available outcome from the drop down list <i>and</i> either the Logic Model is inconsistent with the Narrative <i>or</i> the Narrative is inconsistent with the NOFA.
	3 points	2 points	1 point	0 points
Projections	Applicant <u>provided realistic</u> projected numbers that are consistent with the Narrative for <u>all</u> services, activities, and outcomes.	Applicant <u>provided</u> projected numbers for <u>most</u> services, activities, and outcomes, <i>and</i> 50% or more of the projections are both realistic and consistent with the Narrative.	Applicant <u>provided</u> projected numbers for <u>some</u> services, activities, and outcomes, <i>and</i> More than 50% of the projections are not consistent with the Narrative <i>or</i> are not realistic.	Applicant <u>did not</u> provide any projected numbers, <i>or</i> All of the projections are not consistent with the Narrative <i>and</i> they are not realistic.
	3 points	2 points	1 point	0 points

Appendix B

Logic Model Assessment Matrix

Logic Model Assessment Matrix – Evaluation Tools			
	Satisfactory	Marginally Satisfactory	Unacceptable
Evaluation Tools	Applicant <u>selected</u> Evaluation Tools that are mostly <u>consistent</u> with the project described in the Logic Model and Narrative.	Applicant <u>selected</u> Evaluation Tools that are mostly <u>inconsistent</u> with <u>either</u> the Logic Model or the Narrative.	Applicant selected Evaluation Tools that are mostly <u>inconsistent</u> with <u>both</u> the Logic Model and Narrative, <u>or both</u> the Logic Model and Narrative are <u>inconsistent</u> with the NOFA.
	1 point	0 point	Deduct 1 point
Logic Model Assessment Matrix – Rating Factor Five Narrative			
Align the criteria in Rating Factor Five to the distribution of points in your evaluation plan that you give to reviewers.			

Instructions

A maximum of 10 points are assigned for evaluating and scoring the logic model.

The Logic Model Assessment Matrix identifies the four components that are to be evaluated when scoring the logic model:

- Row—1—Services.
- Row—2—Outcomes.
- Row—3—Projections.

- Row—4—Evaluation Tools.

There are four possible conditions that describe each component represented by the labels (three conditions for the Evaluation component):

- Excellent.
- Good.
- Marginally Satisfactory.
- Unacceptable.

When reviewing and scoring the logic model, HUD reviewers will choose the one statement in each of the four rows (services, outcomes, projections, evaluation tools) that best describes your evaluation of the logic model and add the assigned points to obtain a total score.

[FR Doc. E8-30600 Filed 12-24-08; 8:45 am]

BILLING CODE 4210-67-C

**REMINDER OF UPCOMING CHANGE TO REQUIREMENT FOR
RESIDENT DISCLOSURE OF SOCIAL SECURITY NUMBERS**

On June 29, 2007, a Proposed Rule was published in the Federal Register proposing a revision to HUD's regulations at 24 C.F.R. 5.216 covering the requirements for disclosure of social security numbers. The proposed revision to the regulations requires disclosure of social security numbers by **all** individuals applying for or participating in HUD's rental assistance programs. The Final Rule implementing the revisions to the requirement for disclosure of social security numbers will be published in the Federal Register in the near future. Once the Final Rule is in effect, applicants will be required to disclose and provide verification of the social security number for all members of their household before they can be admitted. Current residents will be required to disclose and provide verification of social security numbers for all members of their household, where disclosure and verification has not occurred, at the time of their next interim or annual recertification.

Owners and management agents are encouraged to begin informing applicants and residents who have not disclosed their social security number, or the social security number of a child under the age of 6, or who have certified they do not have a social security number, of this upcoming revision to the regulations and their need to begin the process of obtaining a social security number.

In addition to the above, owners and management agents who have access to the Enterprise Income Verification (EIV) system should be verifying and correcting social security numbers for individuals listed on the Failed EIV Pre-screening and the Failed Verification Report as having invalid social security numbers.

Section 8 Renewal Policy Guide Page Changes Issued

On December 19, 2008, a revised Chapter 5, *Option Three Referral to OAHP*, to the Section 8 Renewal Policy Guide was posted at: <http://www.hud.gov/offices/hsg/mfh/mfhsec8.cfm#s8rpg> . The posting includes:

Chapter 5, Option Three Referral to OAHP

Appendix 5-1. Implementation of Statutory Authority for Continuing Mark to Market Eligibility (dated April 22, 2002)

Appendix 5-2. Certification of Reduction of Rents in Accordance with Rent/Debt Restructuring Form

Appendix 5-3. Watch List Memorandum Revising guidance on Monitoring OMHAR Watch List Projects (dated September 27, 2001)

Appendix 5-4. Watch List Tracking and Servicing Memorandum (dated July 25, 2002)

Appendix 5-5. Sample Post Closing Transmission Memorandum

Attention Enterprise Income Verification (EIV) System

Multifamily Housing Program Users

News Update: EIV 8.1.1 Instructional Course Webcast

Good News! The agenda and course materials for the December 16-17, 2008 EIV 8.1.1 instructional course webcast are now available on the **EIV Training and Outreach for MF Housing Programs** Web Page at: <http://www.hud.gov/offices/hsg/mfh/rhiip/eiv/eivtraining.cfm> for review and download. We encourage course participants to download and review the materials and become familiar with the case studies prior to joining the webcast at: <http://www.hud.gov/webcasts/index.cfm>. Owners and management agents (O/As), service bureaus, contract administrators (CAs), and HUD staff are all invited to attend. HUD staff will deliver an informative slide presentation ranging from gaining and continuing EIV access, reading income information and verification reports, resolving tenant income discrepancies (including case studies) to monitoring O/A activities, as the Department moves toward eventually mandating the use of EIV for multifamily housing programs.

#129 – Violence Against Women Act (VAWA) Interim Rule Published and NOFA for Rental Assistance for Non-Elderly Persons with Disabilities in Certain Developments – December 5, 2008

Violence Against Women Act (VAWA) Interim Rule Published

The VAWA Interim Rule was published in the Federal Register on November 28, 2008. This interim rule conforms HUD's regulations to the self-implementing provisions of the statutory protections for victims of domestic violence, dating violence, sexual assault, and stalking provided by the VAWA, as amended. **The interim rule applies to HUD's public housing and tenant-based and project-based Section 8 programs.**

Comments on the interim rule are due January 27, 2009.

A copy of the VAWA Interim Rule is posted at: <http://edocket.access.gpo.gov/2008/pdf/E8-28235.pdf>

For additional information on implementation of VAWA in Housing's project-based Section 8 program see Notice H 08-07, "Implementation of the

Violence Against Women and Justice Department Reauthorization Act of 2005 for the Multifamily Project-Based Section 8 Housing Assistance

Payments Program", posted at: <http://www.hud.gov/offices/adm/hudclips/notices/hsg/>

Notice of Funding Availability (NOFA) for Rental Assistance for Non-Elderly Persons with Disabilities in Certain Developments

A NOFA for Fiscal Year 2008 for Rental Assistance for Non-Elderly Persons with Disabilities Related to Certain Types of Section 8 Project-Based Developments and Sections 202, 221(d)(3) and 236 Development (Certain Developments) was published in the Federal Register on November 28, 2008. The NOFA announces the availability of \$15 million in one-year budget authority for Housing Choice vouchers (HCVs) for non-elderly disabled families in support of Certain Developments that provide preferences for, or restrict occupancy to, certain units for occupancy for elderly families only. For more information regarding this NOFA and instructions for applying for the funds, see the Federal Register for November 28, 2008, posted at: <http://edocket.access.gpo.gov/2008/pdf/E8-28237.pdf>

IMPORTANT REMINDER
FOR ALL MULTIFAMILY HOUSING ENTERPRISE INCOME
VERIFICATION (EIV) SYSTEM USERS
EIV 8.1.1 INSTRUCTIONAL COURSE ANNOUNCEMENT

Don't forget to tune in to the in-depth, two-day EIV instructional course.

Course Dates: December 16 and 17, 2008

Course Hours: 11:00 a.m. – 4:00 p.m. (Eastern Time Zone)

Delivery Method: Via HUD web cast at <http://www.hud.gov/webcasts/index.cfm>.

Owners and management agents (O/As), contract administrators and HUD staff are invited to attend the course. The course will be delivered by HUD Headquarters staff and will provide information on gaining and retaining EIV access, security of EIV data, using EIV information and reports and monitoring compliance of O/As using the EIV system.

Prior to the course, the course materials, including the agenda, Power Point presentations and case studies, will be posted to the **EIV Training and Outreach for Multifamily Housing Programs** web page at <http://www.hud.gov/offices/hsg/mfh/rhiip/eiv/eivtraining.cfm> for review and downloading.

Questions concerning the instructional course should be directed to Kevin Garner, Housing Program Manager, who can be reached by telephone at (202) 402-2057 or by email at Kevin.X.Garner@hud.gov.

#127 –Housing & Economic Recovery Act of 2008 Notice; Emergency Capital Repair Grants; & RHIP Tip – November 26, 2008

Housing and Economic Recovery Act of 2008 (HERA) Notice

On November 24, 2008, a Notice was published in the Federal Register providing information about the applicability of certain provisions of the HERA to HUD Public Housing, Section 8 Tenant-Based Voucher and Section 8 Project-Based Voucher Programs. **This Notice also identifies a provision of the law applicable to project-based assisted housing programs administered by the Office of Housing.**

Section 2608 of Title VI of Division B of HERA amends the definition of “annual income” in section 3(b)(4) of the U.S. Housing Act of 1937 to exclude any deferred Department of Veterans Affairs (VA) disability benefits that are received in a lump sum amount or in prospective monthly amounts. As of the effective date of HERA, July 30, 2008, such benefits are not to be included for purposes of determining the annual income of an applicant for or recipient of benefits under the 1937 Act. The full amount of VA disability benefit payments will continue to be included in annual income pursuant to 24 CFR 5.609(b)(4), but the deferred amount resulting from the delayed start of the disability payments will not be included in annual income.

A payment qualifies as a VA disability benefit if it is identified as a disability benefit in the VA benefit award letter, regardless of whether or not the family member that is the beneficiary of the award would qualify as a person with disabilities under HUD’s regulations. For existing residents or tenants, the new exclusion for deferred payments will be made applicable at the time of annual recertification of income, or at interim recertification.

This provision is self-implementing without further regulatory action by HUD. HUD will later publish a conforming rule to include this exclusion with the exclusion of income for deferred Social Security benefits at 24 CFR 5.609(c)(14).

A copy of the Federal Register Notice is located at: <http://edocket.access.gpo.gov/2008/pdf/E8-27871.pdf>

Emergency Capital Repair Grants for Multifamily Housing Projects

Designated for Occupancy by the Elderly

On November 24, 2008, a Notice was published in the Federal Register announcing the availability of \$9.5 million in grant funds to make emergency capital repairs to eligible multifamily projects owned by private nonprofit entities that are designated for occupancy by elderly tenants. The Notice provides instructions for owners to request funding and instructions for the HUD field offices to process such requests.

A copy of the Federal Register Notice is located at: <http://edocket.access.gpo.gov/2008/pdf/E8-27663.pdf>

RHIP TIP: Moving Tenants Who Require Special Features into Accessible Units

If a member of a tenant household becomes disabled with an impairment that requires special accessibility features and the tenant requests an accessible unit, an owner may move that tenant into an accessible unit in lieu of making the tenant’s existing unit accessible and usable. (See Chapter 4 for more information.) However, if a tenant needs only minor modifications to his or her

unit, and does not need a fully accessible unit, the landlord should make the modifications and leave the project's fully accessible units available for tenants who need such units.

For more information on moving tenants who require special features into accessible units, please refer to Chapter 2, Paragraph 2-33 of HUD Handbook 4350.3 REV-1 *Occupancy Requirements of Subsidized Multifamily Housing Programs*.

#126 –2009 Operating Cost Adjustment Factors (OCAFs); and RHIP Tip (Payments for Partial-Month Occupancies) – November 12, 2008

Operating Cost Adjustment Factors (OCAF) Published

The Operating Cost Adjustment Factors (OCAF) for 2009 were published in the November 10, 2008 Federal Register. These factors are used for adjusting or establishing Section 8 rents under the Multifamily Assisted Housing Reform and Affordability Act of 1997 (MAHRA), as amended, and under the Low-Income Housing Preservation and Resident Homeownership Act of 1990 (LIHPRHA) projects assisted with Section 8 Housing Assistance Payments. The factors are effective February 11, 2009. The OCAF factors can be found at <http://www.hud.gov/offices/hsg/mfh/mfhsec8.cfm>.

RHIP Tip: Payments for Partial-Month Occupancies

Owners are entitled to an assistance payment only for the actual number of days during the month that the tenant occupied the unit. If the move-out date is unknown because the tenant failed to notify the owner prior to moving out, the move-out date is the day the vacancy is discovered.

1. Exception for deceased tenants. The owner must prorate the assistance payment for a tenant who died during the month to the earlier of
 - a. 14 days after the tenant's death; or
 - b. The day the unit was vacated.
2. Calculating assistance for units vacated and re-occupied on the same day. For a unit that is vacated and re-occupied on the same day, the owner is only entitled to request assistance for the former tenant through the last full day of occupancy. The owner will request assistance for the new tenant beginning with the move-in day. The owner must never request assistance for both tenants on the same day.

In some cases, an applicant may move into a property while receiving subsidy at their previous residence. During these scenarios, the property in which the applicant is moving in can only bill HUD for subsidy the day following the day subsidy is terminated at the applicant's previous residence. It may be useful to perform a landlord check on the applicant, or utilize the Existing Tenant Search option in the Enterprise Income Verification (EIV) System, to determine if an applicant is receiving assistance somewhere else. At that time, previous management could be informed that their tenant will be moving into another property and their assistance should be terminated.

For more information on payments for partial-month occupancies, please refer to Chapter 9, Paragraph 9-12.E of HUD Handbook 4350.3 REV-1 Occupancy Requirements of Subsidized Multifamily Housing Programs.

UPCOMING CHANGE TO REQUIREMENT FOR RESIDENT DISCLOSURE OF SOCIAL SECURITY NUMBERS

On June 29, 2007, a Proposed Rule was published in the Federal Register proposing a revision to HUD's regulations at 24 C.F.R. 5.216 covering the requirements for disclosure of social security numbers. The proposed revision to the regulations requires disclosure of social security numbers by **all** individuals applying for or participating in HUD's rental assistance programs. The Final Rule implementing the revisions to the requirement for disclosure of social security numbers will be published in the Federal Register in the near future. Once the Final Rule is in effect, applicants will be required to disclose and provide verification of the social security number for all members of their household before they can be admitted. Current residents will be required to disclose and provide verification of social security numbers for all members of their household, where disclosure and verification has not occurred, at the time of their next interim or annual recertification.

Owners and management agents are encouraged to begin informing applicants and residents who have not disclosed their social security number, or the social security number of a child under the age of 6, or who have certified they do not have a social security number, of this upcoming revision to the regulations and their need to begin the process of obtaining a social security number.

REVISION TO PET RULES RELATING TO PERSONS WITH DISABILITIES

The Final Rule revising the regulations on Pet Ownership for the Elderly and Persons with Disabilities was published in the Federal Register on October 27, 2008. The Final Rule is effective on November 26, 2008.

The Final Rule revises 24 C.F.R. 5.303 covering the exclusion of animals that assist, support or provide services to persons with disabilities from the pet ownership rules. The revision to the regulations:

- Expands the definition of animals covered by the exclusion to "animals used to assist, support, or provide services to persons with disabilities."
- Clarifies that owners and management agents may not enforce any policies established for pets against animals that are necessary as a reasonable accommodation to assist, support or provide services to persons with disabilities.
- Removes the training and tenant certification requirements in order for an animal to qualify for the exclusion.

The Final Rule is posted on HUDCLIPS at: <http://edocket.access.gpo.gov/2008/pdf/E8-25474.pdf>

For more information on assistance animals as a reasonable accommodation, see HUD Handbook 4350.3 REV-1, *Occupancy Requirements of Subsidized Multifamily Housing Programs*, Chapter 2, paragraph 2-44.

RHIIP TIP: Dependent Deduction

When more than one family shares custody of a child and both live in assisted housing, only one family at a time can claim the dependent deduction for that child. The family with primary custody or with custody at the time of the initial certification or annual recertification receives the

deduction. If there is a dispute about which family should claim the dependent deduction, the owner should refer to available documents such as copies of court orders or an IRS return showing which family has claimed the child for income tax purposes.

For more information on dependent deductions, please refer to Chapter 5, Paragraph 5-10 of HUD Handbook 4350.3 REV-1 *Occupancy Requirements of Subsidized Multifamily Housing Programs*.

Attention Enterprise Income Verification (EIV) System

Multifamily Housing Program Users

News Update: EIV 8.1.1 Fix Release & Instructional Course

EIV 8.1.1 Fix Release

The EIV 8.1.1 Fix Release was successfully implemented for multifamily housing programs on October 24, 2008. See attached “What’s New in EIV 8.1.1 for MF Housing Users?” which summarizes changes made with this release. The next EIV Fix Release is tentatively scheduled for April 2009.

EIV 8.1.1 Instructional Course — *Save the Date!*

On December 16-17, 2008, an in-depth, two-day EIV 8.1.1 instructional course will be conducted by HUD staff via Webcast at: <http://www.hud.gov/webcasts/index.cfm>. Owners and management agents (O/As), service bureaus, and contract administrators (CAs) are all invited to attend. As with the June 2007 course, HUD staff will deliver an informative slide presentation ranging from gaining and continuing EIV access, reading income information and verification reports, resolving tenant income discrepancies (including case studies) to monitoring O/A activities, as the Department moves toward eventually mandating the use of EIV for multifamily housing programs.

Logistical course information will be posted to the **EIV Training and Outreach for MF Housing Programs** web page at: <http://www.hud.gov/offices/hsg/mfh/rhiip/eiv/eivtraining.cfm> and communicated through Multifamily’s RHIP Listserv. We encourage you to sign-up and stay updated on RHIP-related news.

<<WHAT's new EIV 8 1 1 MF rev.doc>>

RHIP Tip: Determining the Cash Value of Assets

The “cash value” of an asset is the market value less reasonable expenses that would be incurred in selling or converting the asset to cash, such as the following:

- (1) Penalties for premature withdrawal;
- (2) Broker and legal fees; and
- (3) Settlement costs for real estate transactions.

The cash value is the amount the family could actually receive in cash, if the family converted an asset to cash.

For more information on determining the cash value of assets, please refer to Chapter 5, Paragraph 5-7 of HUD Handbook 4350.3 REV-1 *Occupancy Requirements of Subsidized Multifamily Housing Programs*.

WHAT's new in EIV 8.1.1 for MF Users?

Function	Description
UAAF – User Access Authorization Form - Certification of completion for requests acted on prior to May 09, 2008 release,	For UAAFs concerning users with the Housing User (HSU) and Contract Administrator User (CAU) roles, the checkbox and Certification of Completion—Security Awareness Training Questionnaire has been removed from all of the electronic UAAFs that were “Approved,” “Denied,” or put “On Hold” by users with the Housing Coordinator (HSC) or Contract Administrator Coordinator (CAC) roles prior to the May 09, 2008 EIV 8.1 Release.
CAAF – Coordinator Access Authorization Form - Certification of completion for requests acted prior to May 09, 2008	For CAAFs concerning users with the Housing User (HSU) and Contract Administrator User (CAU) roles, the checkbox and Certification of Completion—Security Awareness Training Questionnaire has been removed from all of the electronic CAAFs that were “Approved,” “Denied,” or put “On Hold” by users with the Helpdesk Personnel (HDK) role prior to the May 09, 2008 EIV 8.1 Release.
UAAF and CAAF (for Certification Requests Only) - Remove Certification of completion of Security Awareness Training.	The Certification of Completion— <i>Security Awareness Training Questionnaire</i> checkbox has been removed from UAAF forms for Certification for users with the HSU and CAU roles and from CAAF forms for Certification for users with the HSC and CAC roles .
View User Expiration	A new report is available for HDK users to query the expiration history of an external user using the user's ID.
Change to role requirement for users with HFU role to access EIV	Users with the HFU role will no longer be required to have TRACS roles, TTQ – TRACS Query and TVQ – TRACS Voucher Query, assigned to them in Web Access Secure Systems (WASS) in order to gain access to EIV. Instead, they will need to have the QRY – Database Query Action assigned to them through “Maintain User Profile—Actions” in WASS.
221(d)(3) BMIR and 236 searches by Project Number – Income Report information	Users will be able to search income reports for all tenants in 221(d)(3) BMIR and 236 properties.
Report Printouts – Masking the user ID shown on printed reports.	In order to prevent theft of WASS IDs, the last 3 characters of the User ID displayed on each page of the printed reports is being masked.
Failed EIV Pre-Screening Report	Implemented text change throughout Failed EIV Pre-Screen Report replacing “Pre-Screen” with “Pre-Screening”.
Household Income Report	Implemented text change throughout Household Income Report replacing "Family Member" with "Household Member".
Deceased Tenants Report- Result Display: Displaying an asterisk beside the Deceased Date.	For single member deceased households, a red asterisk (*) is being placed to the right of the deceased date (even if the deceased date value is listed as 'N/A') in the Deceased Tenant Report result page.

#123 – TRACS Release 202C/iMAX; and RHIP Tip (Occupancy – Single Person in Two or More Bedroom Unit) – October 9, 2008

TRACS Release 202C/iMAX

Attached to this listserv message is a memorandum dated October 8, 2008, from Lanier Hylton, Director, Office of Program Systems and Willie Spearmon, Director, Office of Housing Assistance and Grant Administration, along with three Attachments.

The purpose of the memorandum is to:

- Inform you that on September 5, 2008, the Office of Management and Budget (OMB) provided emergency approval of the forms associated with the TRACS Release 202C/iMAX;
- Provide you with the Information Technology Implementation Schedules;
- Address implementation requirements for other forms included in the OMB emergency approval package, many of which do not have any changes from what are currently posted on HUDCLIPS, with the exception of the OMB expiration date which is discussed in the memorandum.
- Inform you of the release of the new HUD forms included in Housing Notice H 08-07 "Implementation of the Violence Against Women and Justice Department Reauthorization Act of 2005 for the Multifamily Project-Based Section 8 Housing Assistance Payments Program".
- Provide the Software Vendor/In House Developer HUD Forms Requirement Matrix, describing the software display requirements for the HUD forms,

Attachment 3.

In addition, due to the amount of requests for further clarification of the September 18, 2008 memorandum from Janet Golrick, Acting Deputy Assistant Secretary for Multifamily Housing Programs, on use of the HUD Model Lease, the Department has:

- Revised the Model Lease Questions and Answers, Attachment 1.
- Developed a grid entitled "What Lease Do I Use", Attachment 2.

Questions relating to the lease requirements should be addressed to Michael Sharkey at Michael.A.Sharkey@hud.gov or by calling (202) 402-6788.

All of the documents attached to this Listserv message will be posted on the Multifamily RHIP website at: <http://www.hud.gov/offices/hsg/mfh/rhiip/mfhrhiip.cfm>

RHIP TIP: Occupancy – Single Person in Two or More Bedroom Unit

A single person must not be permitted to occupy a unit with two or more bedrooms unless they fall under one of the exceptions below:

- a. A person with a disability who needs the larger unit as a reasonable accommodation.
- b. A displaced person when no appropriately sized unit is available.
- c. An elderly person who has a verifiable need for a larger unit.
- d. A remaining family member of a resident family when no appropriately sized unit is available.

For more information on assigning units larger than required, please refer to Chapter 3, Paragraph 3-23.G of HUD Handbook 4350.3 REV-1 *Occupancy Requirements of Subsidized Multifamily Housing Programs*.

Summary of guidance on modifications to the TRACS tenant certification process.

HUD (Lanier M. Hilton and Willie Spearmon) issued guidance on October 8, 2008, concerning modifications to the TRACS tenant certification process through changes to certain HUD forms. On September 5, 2008, the Office of Management and Budget (OMB) provided emergency approval of the forms listed below that are associated with TRACS Release 202C and to provide implementing instructions regarding all of the forms that were included in the OMB emergency approval:

TRACS 202C HUD Forms

- HUD-50059 – Owner’s Certification of Compliance with HUD’s Tenant Eligibility and Rent Procedures;
- HUD-50059-A – Owner’s Certification of Compliance with HUD’s Tenant Eligibility and Rent Procedures – Partial Certification;
- HUD-52670-A Part 1 – Schedule of Tenant Assistance Payments Due;
- HUD-52670-A Part 3 – Adjustments to Schedule of Tenant Assistance Payments Due;
- HUD-52670-A Part 4 – Miscellaneous Accounting Request for Schedule of Tenant Assistance Payments Due; and
- HUD-52670-A Part 5 – Approved Special Claims for Schedule of Tenant Assistance Payments Due

The following forms were part of the OMB approved paperwork package but were not changed from those currently posted to HUDCLIPS (with the exception of the OMB expiration date)

- HUD-52670 – Housing Owner’s Certification and Application for Housing Assistance Payments
- HUD-52670-A Part 2 – Schedule of Section 8 Special Claims;
- HUD-90105-A – Model Lease for Subsidized Programs;
- HUD-90105-B – Model Lease for Section 202/8 or Section 202 PAC;
- HUD-90105-C – Model Lease for Section 202 PRAC;
- HUD-90105-D – Model Lease for Section 811 PRAC;
- HUD-90106 – Sample Move-In/Move-Out Inspection Form;
- HUD-90100 – Sample Recertification Notice;
- HUD-90101 – Sample Certification of Long Term Care Insurance;
- HUD-90102 – Sample Verification of Disability (for All Programs Except Section 202/8, Section 202 PAC, Section 202 PRAC, and Section 811 PRAC);
- HUD-90103 – Sample Verification of Disability (for Section 202/8, Section 202 PAC, Section 202 PRAC, and Section 811 PRAC);
- HUD-90104 – Sample Exception to Limitations on Admission of Families;
- HUD-9887/9887-A – Consent for the Release of Information forms;
- HUD-27061-H – Race and Ethnic Data Reporting form;
- HUD-52671-A – Section 8 Special Claims for Unpaid Rent/Damages;
- HUD-52671-B – Section 8 Special Claims for Vacancies During Rent-up;
- HUD-52671-C – Section 8 Special Claims for Regular Vacancies; and
- HUD-52671-D – Section 8 Special Claims for Debt Service.

The following two new forms were also including in the OMB approved paperwork package. They were attached to Housing Notice H08-07, *“Implementation of Violence Against Women and Justice Department Reauthorization Act of 2005 for the Multifamily Project-Based Section 8 Housing Assistance Payments Program”* issued on September 30, 2008.

- Form HUD-91066 (Victim of Domestic Violence, Dating Violence, or Stalking Certification Form); and

- Form HUD-91067 (Lease Addendum for Violence Against Women Act (VAWA))

Under the OMB emergency approval, software vendors and in-house developers will no longer have to display an OMB expiration date in their applications version of the forms listed above with the exception of the Model Leases and HUD-9887/9887A*. Vendors and developers must however inform their users to reference HUDCLIPS (www.hud.gov/udclips) for the official form with the OMB expiration date. Software vendors and in-house developers are STILL required to display/print the OMB approval number which will not change. HUD suggests that Software Vendors and In-house Developers include the HUDCLIPS reference in their application documentation.

*The Model Leases and HUD-9887/9887A, Consent for the Release of Information forms, are not required to display the OMB expiration date or the OMB approval number, per the September 18, 2008, memorandum from Janet Golrick, entitled "Clarification on HUD Model Leases". Since the release of the September 18, 2008, memorandum, HUD has revised the Model Lease Questions and Answers that were posted on the Multifamily Rental Housing Integrity Improvement Project (HIIP) website; developed a grid entitled, "What Lease Do I Use?"; and prepared a "Software Vendor/In-House Developer HUD Forms Requirement Matrix describing software display requirements for HUD forms.

HUD is in the process of posting the latest versions of the approved forms on HUDCLIPS.

Information Technology Implementation Schedules

1. TRACS integrated Multifamily Access eXchange (iMAX) Implementation Schedule
iMAX became operational September 29, 2008. iMAX users will need a WASS ID and password as well as an iMAX ID and password (previously known as the TRACSMail User ID and Password.) Users can request an iMAX ID and password by contacting the Multifamily Housing Help Desk at 800-767-7588 or email TRACS@hud.gov.

The Web services URL for iMAX is <https://www21.hud.gov/IMAX-WS>

Users are advised to remember

- To test iMAX, use the iMAX vendor region web service link:
<https://www.21.hud.gov/IMAX-WSPILOT/access>
- To test MAT files, use the iMAX production web browser (available through WASS at https://www.hud.gov/HUD_Systems) or production web services (link: <https://www21.hud.gov/IMAX-WS>) and send files to TRACMTEST.
- For production fields, use the iMAX production web browser (available through WASS at https://www.hud.gov/HUD_Systems) or production web services (link: <https://www21.hud.gov/IMAX-WS>) and send files to TRACMPROD.
- A valid WASS ID is required. If you do not currently have a WASS Multifamily (M) ID please use the following link to request one:
https://hudapps.hud.gov/public/wass/public/independent/indreg_page.jsp
- If you currently have a WASS (M) ID and access to TRACS online queries, you will automatically be assigned the iMAX role.
- Report all problems and and/or questions related to iMAX testing to:
MF_TRACS_TM_WRKGRP@hud.gov
- All new WASS IDs must be added to the LDAP directory for web services. This is handled by another department in HUD which can take up to 3 days to complete.

2. Contract Administrator Transition Responsibilities for iMAX

Performance Based Contract Administrators (PBCAs) and Traditional Contract Administrators (TCAs) must be read to use both iMAX and TRACSMail effective December 1, 2008.

3. TRACSMail Termination Date

The Department will terminate support for TRACSMail effective February 28, 2009. Owners, PBCAs, and TCAs must use iMAX to transmit tenant certification and voucher data as of March 1, 2009.

4. TRACS Transition Responsibilities to Accept/Process TRACS Releases 202B and 202C

TRACS will accept and process both TRACS 202B and 202C Monthly Activity Transmissions (MATs) effective September 29, 2008.

5. Contract Administrator Transition Responsibilities to Process/Transmit TRACS Releases 202B and 202C

PBCAs, and TCAs must be ready to accept both TRACS 202B and 202C Monthly Activity Transmissions (MATs) commencing December 1, 2008 through March 31, 2009.

6. TRACS Termination Date for TRACS Release 202B MAT Support

TRACS will provide support for TRACS 202B transmissions until March 31, 2009. Effective April 1, 2009, owners, PBCAs, and TCAs must use TRACS Release 202C MAT format to transmit tenant certification and voucher data. TRACS will NOT accept TRACS 202B transmissions effective April 1, 2009.

Those with questions on the 202C requirements are directed to Mf_Tracs_Working_Group@hud.gov while questions concerning OMB approval numbers and expirations dates should contact Mike Sharkey at 202-402-6788.

HUD MODEL LEASES QUESTIONS AND ANSWERS

Question 1: What is the definition of a HUDCLIPS lease?

Answer 1: A HUDCLIPS lease is any one of the OMB approved four model leases obtained by going to www.hud.gov/hudclips and either printing a hard copy of the lease directly from HUDCLIPS and writing or typing in the information required to be filled in by the owner/management agent (O/A) or using the form fillable lease on HUDCLIPS, when available.

Question 2: What information must be included on the OMB approved lease?

Answer 2: The answer depends on how the O/A produces the OMB approved lease. If the O/A uses TRACS software or other purchased computer software, then the OMB approved lease must contain the public reporting burden language, the HUD form number and form approval date. If the O/A uses the HUDCLIPS lease it will automatically contain the OMB approval number, OMB expiration date, HUD form number and form approval date.

Question 3: When must owners/agents (O/As) start using the OMB approved model leases?

Answer 3:

Leases Generated by TRACS Software or Other Purchased Computer Software

- Without HUD/CA Approved Modifications
 - New Tenants – O/As do not have to use the OMB approved lease until the earlier of the software being updated to the computer generated OMB approved leases, or HUD issues revisions to the lease language. The computer-generated leases do not need to include the OMB approval number or the OMB expiration date.
 - Existing Tenants – Existing tenants will remain on the lease they originally signed unless they are required to sign a new lease in instances such as when the tenant moves to a new unit or when HUD issues modifications to the lease.
- With HUD/CA Approved Modifications
 - New Tenants – O/As may continue using these leases until such time as HUD issues modifications to the language in the leases. Once HUD issues modifications to the language in the leases, the O/A must begin using the OMB approved leases, which will contain

the HUD modifications. At that time, any O/A modifications to the lease will have to be moved to a lease addendum (see Question 20).

- Existing Tenants – Existing tenants will remain on the lease they originally signed unless they are required to sign a new lease in instances such as when the tenant moves to a new unit or when HUD issues modifications to the lease.

HUDCLIPS Lease

O/As using the HUDCLIPS lease by going into HUDCLIPS from their computer and either printing a hard copy of the lease directly from HUDCLIPS and writing or typing in the information required to be filled in by the O/A or using the form fillable lease on HUDCLIPS, when available, must begin using the OMB approved lease now for new admissions.

Question 4: If the O/A's TRACS or other purchased software was already updated to include the OMB approval number and OMB expiration date prior to notification that this information was not required and the leases were issued to tenants, will the O/A have to re-issue the leases when the OMB expiration date expires and a new OMB expiration date is approved?

Answer 4: No, the OMB approval number and OMB expiration date are not required to be on leases generated by TRACS or other software purchased by the O/A. Therefore, the O/A would not need to re-issue leases to the tenants when the OMB expiration date expires and a new OMB expiration date is approved as posted on HUDCLIPS.

Question 5: Does the public reporting burden language have to be included at the end of the lease or can it be removed?

Answer 5: When updating TRACS or O/A purchased software, the OMB approved lease must include the public reporting burden language, HUD form number and form approval date. OMB has given HUD approval not to include the OMB approval number or OMB expiration date on leases generated by TRACS or O/A purchased software. The HUDCLIPS lease (see Question 1 for definition) will automatically include the OMB approval number, OMB expiration date, public reporting burden language, HUD form number and form approval date.

Public Reporting Burden language that must be included on all OMB approved leases:

“Public reporting burden: HUD is not requesting approval of any burden hours for the model leases since use of leases are a standard business practice in the

housing rental industry. This information is required to obtain benefits. The request and required supporting documentation are sent to HUD or the Contract Administrator (CA) for approval. The lease is a contract between the owner of the project and the tenant(s) that explains the terms for residing in the unit. Leases are a standard business practice in the housing rental industry. Owners are required to use the HUD model lease which includes terms normally covered by leases used in the housing rental industry plus terms required by HUD for the program under which the project was built and/or the program providing rental assistance to the tenants.

This information is authorized by 24 CFR 5.360, 236.750, 880.606, 883.701, 884.215, 886.127, 891.425 and 891.765 covering lease requirements and provisions. This information is considered non-sensitive and does not require any special protection.”

Question 6: If the tenant has initially fulfilled the 1-year lease requirement, must he/she fulfill this requirement again or does the month-to-month lease term apply?

Answer 6: If the tenant has fulfilled the 1-year lease requirement, the month-to-month lease term will apply.

Question 7: Most Section 8 programs require a minimum lease term of one year. We have always computed this as starting on a date and ending the day before, one year later. A lease starting on January 1st would end on December 31st. However, the lease instructions in Appendices 4 E and G state that the term would end on the “same day one year later”. I do not believe that to be correct and there are PBCAs using that guidance to cite non-compliance on MORs. Is there a clarification on this?

Answer 7: The definition for the initial term of the lease in the instructions in Appendices 4 E, F and G is being revised to twelve calendar months beginning at any point, e.g., beginning January 1 and ending December 31; or beginning May 1 and ending April 30. O/As may use this definition when completing the initial term section of the lease.

Question 8: How should the lease term be completed when the tenant has fulfilled the initial one-year term and is now on a month-to-month lease?

Answer 8:

A. HUD Model Lease for Subsidized Programs, Form HUD-90105-a, paragraph 1 should be completed by inserting the beginning and ending day of the month the lease is issued to the tenant. The “initial” term in this case is for one month. The successive term would be for one “month”. For example, if the lease were issued on July 1, 2008, paragraph 1 would read as follows:

1. The initial term of this Agreement shall begin on July 1, 2008 and end on July 31, 2008. After the initial term ends, the Agreement will continue for successive terms of one month each unless automatically terminated as permitted by paragraph 23 of this Agreement.

B. HUD Model Leases for Section 202/8 or Section 202 PACs, Section 202 PRACs and Section 811 PRACs, HUD Forms 90105-b, c and d, respectively, will require a lease addendum modifying paragraph 1 of the leases indicating the month-to-month lease term. If the addendum only includes modification to paragraph 1 of the lease, the addendum does not have to be approved by HUD/CA. See Question 20 for additional information on modifications to the lease that were previously approved by HUD/CA.

Question 9: If an O/A has the lease translated to a different language used for reference purposes, should the alternative language lease include any reference to the OMB number, OMB expiration date and public reporting burden information or is the OMB information on the executed, English version of the lease sufficient?

Answer 9: The OMB information would only be included if the leases were translated and issued by HUD. Translated leases that are not issued by HUD must not include the OMB information. The executed English version would be the only lease required to have the appropriate OMB information, depending on how the lease is generated (i.e., TRACS software/other purchased computer software or HUDCLIPS produced).

Question 10: Most of our tenant population is Spanish speaking, do we have to use the English version of the OMB approved lease or can we use a Spanish version of the lease?

Answer 10: Residents who speak Spanish should be provided the lease that has been translated to Spanish in order for them to read and understand the lease provisions. However, the official, signed copy is the English version of the lease.

Question 11: All of the leases have blanks that are to be completed by the O/A. Can these blanks be completed within the leases themselves or must the information be placed on a lease addendum?

Answer 11: Wherever there is a blank within the lease that needs to be completed by the O/A, the O/A may complete the blank fields within the leases themselves in accordance with Appendices E, F and G of Handbook 4350.3 REV-1, *Occupancy Requirements of Subsidized Multifamily Housing Programs*.

Question 12: When an O/A modifies the lease using an approved lease addendum, should the OMB information be included on the addendum?

Answer 12: No, the OMB approval number, OMB expiration date, public reporting burden, HUD form number and form approval date should not be on the addendum.

Question 13: Since the leases now have an expiration date, does that mean the leases cannot be used in perpetuity?

Answer 13: If the O/A is using the lease generated by their TRACS or other purchased computer software, the OMB approval number and the OMB expiration date are not required to be on the lease thereby eliminating the need to re-issue leases.

If the O/A is using the lease directly from HUDCLIPS (see Question 1, above), the O/A will be required to use the lease with the new OMB expiration date for new tenants and when a new lease needs to be issued to an existing tenant for any reason (e.g., tenant moves to a different unit).

Question 14: Can the size of the font be increased or decreased, the font style changed, formatting corrected, misspelled words corrected, etc.?

Answer 14: The text/words and overall format of the leases must be identical to the OMB approved leases. However, O/As may correct typographical errors, such as errors in spelling; change font size and style; correct formatting, if needed; make the margins wider or narrower; and, re-paginate pages.

Question 15: Does the HUD form number and form approval date have to be included on the lease?

Answer 15: On leases generated by TRACS software or other software purchased by the O/A, the OMB approval number and OMB expiration date does not have to be on the leases. On the HUDCLIPS lease, it must remain as printed out directly from the HUDCLIPS website.

Question 16: Can the Fair Housing logo be included in the footer to the lease?

Answer 16: Yes

Question 17: Can the O/A transfer the model lease to his/her letterhead in order to provide company name, address, telephone numbers, etc. to ensure that legal requirements are met?

Answer 17: No, O/As should not transfer the OMB approved lease to his/her letterhead. If more information is needed relative to the location of the company, telephone numbers, etc. a cover page can be added to the lease.

Question 18: The Section 202/8 or Section 202 PAC, Section 202 PRAC and Section 811 PRAC leases do not have a field for the unit number? Can a unit number field be added?

Answer 18: No. As stated in the instructions for completing the leases (Appendices 4-F and 4-G) the field in paragraph 1 with the alphabetical letter "D" states: Enter the dwelling unit number and name of the project. Paragraph 1 of the leases would read: "The LANDLORD leases to the TENANT, and the TENANT leases from the LANDLORD dwelling unit in the project known as Unit 205, U.S.A. Apartments....."

Question 19: If an O/A has an elderly property requiring the use of the HUD Model Lease for Subsidized Programs and has incorporated into the lease the pet language from the Section 202/8 lease can this language be incorporated into the OMB approved lease?

Answer 19: No. The language will have to be incorporated into the OMB approved lease by use of a lease addendum. As long as the language was incorporated into the lease previously and is the identical language that is in the Section 202/8 lease, the addendum will not have to be approved by HUD/CA.

Question 20: If an O/A has modified the lease to be in compliance with state law and the modifications have been approved by HUD/CA, can the O/A incorporate the approved modifications into the lease with the OMB information?

Answer 20: No. Any modifications to the OMB approved lease must be incorporated with the use of a lease addendum. However, O/As may continue using the 5/2003 lease or the 5/2003 lease with the 6/2007 page changes **and** where the lease has HUD/CA approved modifications until such time as HUD issues modifications to the language in the leases (see Question 3, above).

Lease modifications approved by HUD/CA, will not have to be approved again when moved to the lease addendum as long as there is no change in the previously approved modification language. Any new modifications or modification language changes must be approved by HUD/CA.

Question 21: What do we do with properties using leases provided by the contract administrator (CA)? Some states have significantly different lease requirements and CAs have developed leases that O/As are required to use. Will the CAs instruct the O/As to use the HUD model leases and the CA will then provide an approved lease addendum?

Answer 21: O/A should be using the HUD model leases and not leases developed by CAs. HUD model leases that have been modified to include state requirements must have the state requirements incorporated by use of a lease addendum. Whether or not the CA will provide the approved lease addendum or whether it will be up to the O/A to develop, we cannot answer. Normally it is the O/A's responsibility to ensure that the lease is in compliance with state laws.

However, for projects financed by a State Agency and under the jurisdiction of a Traditional Contract Administrator (TCA), the O/A will continue to use the lease provided by the State Agency as addressed in paragraph 6-5 A.2 of Handbook 4350.3 REV-1, *Occupancy Requirements of Subsidized Multifamily Housing Programs*.

Question 22: The HUD model leases for Section 202/8 or Section 202 PAC (paragraph 16) and Section 202 PRAC and Section 811 PRAC (paragraph 14) contain some optional language the O/A can elect to include in the lease. If the O/A elects not to use this language, can this optional paragraph be removed from the lease they use?

Answer 22: If the O/A elects not to use the optional language, the optional language can be removed from the OMB approved lease. If the O/A elects to use the optional language, the word "Optional" can and should be removed at the beginning of the paragraph.

What Lease Do I Use?

Lease Date	Tenant Status	Owner is using TRACS Software or Software purchased by Owner/Agent	Owner is using Lease with modifications approved by HUD/CA prior to the release of the OMB approved leases	Owner is using the HUDCLIPS Lease* (see definition below)
5/2003 Lease Section 202 PRAC Lease Section 811 PRAC Lease NOTE: No page changes to leases in 6/2007	<u>New Tenant</u>	▲ May continue to use if software has not been updated to the 12/2007 OMB approved lease until the earlier of software updates by the developer or revisions to the lease language provided by HUD.	▲ May continue to use until such time as HUD issues modifications to the language in the leases.	▲ Not Applicable
	<u>Existing Tenant</u>	▲ Stays on lease currently signed by tenant unless tenant is required to sign a new lease (e.g. moving to a new unit, in which case tenant would sign the lease currently being used for new tenants) or HUD issues modifications to the lease.	▲ May continue to use until such time as HUD issues modifications to the language in the leases.	▲ Not Applicable
5/2003 Lease with 6/2007 page changes Model Lease for Subsidized Programs Section 202/8 or Section 202/PAC Lease	<u>New Tenant</u>	▲ May continue to use if software has not been updated to the 12/2007 OMB approved lease until the earlier of software updates by the developer or revisions to the lease language provided by HUD.	▲ May continue to use until such time as HUD issues modifications to the language in the leases.	▲ Not Applicable
	<u>Existing Tenant</u>	▲ Stays on lease currently signed by tenant unless tenant is required to sign a new lease (e.g. moving to a new unit, in which case tenant would sign the lease currently being used for new tenants) or HUD issues modifications to the lease.	▲ May continue to use until such time as HUD issues modifications to the language in the leases.	▲ Not Applicable
12/2007 OMB Approved Lease	<u>New Tenant</u>	▲ Use if software has been updated to the 12/2007 OMB approved lease. NOTES: 1) Lease does not need to contain the OMB approval number or OMB expiration date but must include the Public Reporting Burden language, HUD form number and form approval date. 2) Modifications to the OMB approved lease must be included as a lease addendum. Modifications previously approved by HUD/CA do not have to be approved again when moved to an addendum. However, new modifications must be approved by HUD/CA.	▲ Can use if HUD/CA approved modifications are put in a separate lease addendum.	▲ Must use the 12/2007 OMB approved lease
	<u>Existing Tenant</u>	▲ Stays on lease currently signed by tenant unless tenant is required to sign a new lease (e.g. moving to a new unit, in which case tenant would sign the lease currently being used for new tenants) or HUD issues modifications to the lease.	▲ Stays on lease currently signed by tenant unless tenant is required to sign a new lease (e.g. moving to a new unit, in which case tenant would sign the lease currently being used for new tenants) or HUD issues modifications to the lease.	▲ Stays on lease currently signed by tenant unless tenant is required to sign a new lease (e.g. moving to a new unit, in which case tenant would sign the lease currently being used for new tenants) or HUD issues modifications to the lease.

* The HUDCLIPS Lease is the OMB approved lease that includes the Public Reporting Burden language, OMB approval number, OMB expiration date, HUD form number and form approval date. It is downloaded and printed directly from the HUDCLIPS website at: www.hud.gov/hudclips. Information is filled in online, when available, or by hand or typewriter.

Attachment 3
Software Vendor/In-house Developer HUD Forms Requirement Matrix

HUD Form Number	New/Revised HUD Form	HUD Form Number Approval Date Public Reporting Burden Display Required	OMB Approval Number Display Required	OMB Expiration Date Display Required
HUD-50059	Yes	Yes	Yes	No
HUD-50059-A	Yes	Yes	Yes	No
HUD-52670	No	Yes	Yes	No
HUD-52670-A Part 1	Yes	Yes (1)	Yes	No
HUD-52670-A Part 2	No	Yes	Yes	No
HUD-52670-A Part 3	Yes	Yes (1)	Yes	No
HUD-52670-A Part 4	Yes	Yes (1)	Yes	No
HUD-52670-A Part 5	Yes	Yes (1)	Yes	No
HUD-91066	Yes	Yes	Yes	No
HUD-91067	Yes	Yes	Yes	No
HUD-9887	No	Yes	No	No
HUD-9887-A	No	Yes	No	No
HUD-90100	No	Yes	Yes	No
HUD-90101	No	Yes	Yes	No
HUD-90102	No	Yes	Yes	No
HUD-90103	No	Yes	Yes	No
HUD-90104	No	Yes	Yes	No
HUD-90105-A	No	Yes	No	No
HUD-90105-B	No	Yes	No	No
HUD-90105-C	No	Yes	No	No
HUD-90105-D	No	Yes	No	No
HUD-90106	No	Yes	Yes	No
HUD-27071-H	No	Yes	Yes	No
HUD-52671-A	No	Yes	Yes	No
HUD-52671-B	No	Yes	Yes	No
HUD-52671-C	No	Yes	Yes	No
HUD-52671-D	No	Yes	Yes	No

(1) The Public Reporting Burden Display is not required for this form; however, the form displays the following statement “See the statements on the form HUD-52670 for information on public burden.”

#122 – Violence Against Women Act (VAWA) Guidance; and RHIP Tip (EIV and Tenant Income) – October 8, 2008

Guidance on Implementation of the Violence Against Women Act (VAWA)

Notice H 08-07, *Implementation of the Violence Against Women and Justice Department Reauthorization Act of 2005 for the Multifamily Project-Based Section 8 Housing Assistance Payments Program*, providing guidance on implementation of VAWA by owners and management agents administering one of Multifamily Housing's project-based Section 8 programs was issued on September 30, 2008 and is now posted on HUDCLIPS at: <http://www.hud.gov/offices/adm/hudclips/notices/hsg/files/08-07HSGN.doc>. VAWA provides legal protections to victims of domestic violence, dating violence or stalking.

In addition to the Notice, two new forms were also released for use in the implementation of VAWA. These forms will be posted on HUDCLIPS soon.

- Form HUD-91066, Certification of Domestic Violence, Dating violence or Stalking
- Form HUD-91067, Lease Addendum – Violence Against Women and Justice Department Reauthorization Act of 2005

It is important to note that **VAWA applies to all Section 8 programs** regardless of whether a specific reference to a program is included in the Notice. The Applicability section of the Notice will be revised to clarify this and include additional programs identified, e.g., the Pension Fund program.

RHIP Tip:

With the use of the employment and income information from the Enterprise Income Verification (EIV) system many owners/agents (O/As) are finding that some of their tenants have not disclosed all of their income information and, in many instances, the non-disclosure of income goes back for a number of years. When resolving income discrepancies, including non-reporting of income by tenants, the O/A is required to obtain written independent verification directly from the third party source. This Listserv message is to call to your attention that the consent form HUD-9887-A signed by the tenant(s) limits how far back the O/A can request information from the third party source in order to resolve an income discrepancy and for use in determining any reimbursement to the O/A by the tenant for underpayment of rent, when applicable. The time limit is for the 5 year period prior to the date the consent forms for the **current** certification period were signed by the tenant(s) as these are the only consent forms in effect, all other consent forms signed for previous certification periods have expired.

HUD-9887-A, Applicant's/Tenant's Consent to the Release of Information

The HUD-9887-A consent form allowing the O/A to obtain third party verifications limits O/As from making inquiries into information that is older than 12 months unless he/she received inconsistent information and has reason to believe that the information that the tenant has supplied is incorrect. If this occurs then the O/A is limited to obtaining information within the last 5 years when the tenant has received assistance.

Before O/As may take any action (terminate, deny, suspend or reduce any assistance) against a tenant who may not have reported all of his/her income, O/As must follow the guidance in Handbook 4350.3 REV-1, *Occupancy Requirements of Subsidized Multifamily Housing Programs*, Chapter 8, Section 4. Additional guidance for resolving income discrepancies may also be found in Notice H 2008-03, Enterprise Income Verification (EIV) posted on HUDCLIPS at: <http://www.hud.gov/offices/adm/hudclips/notices/hsg/files/08-03HSGN.doc> and in the document

titled "Resolving Income Discrepancies between Tenant Provided and Enterprise Income Verification (EIV) System Income Data" posted on the Multifamily EIV website at: <http://www.hud.gov/offices/hsg/mfh/rhiip/eiv/resincdisc.pdf>.

Section 8 Renewal Policy Guide Page Changes Issued

On September 26, 2008, Brian Montgomery, Assistant Secretary for Housing - Federal Housing Commissioner, approved the publication of several page changes to the Section 8 Renewal Policy Guide. Specifically,

a. Chapter 15 has been revised to simplify its use. There are two key changes in the chapter. First is the removal of the 6 percent return on equity. This passage is being moved to a new Chapter 2 that will be released in the near future. Secondly, the prohibition of identity-of-interest transfer transactions has been removed.

b. Attachment 20 is a new attachment that provides for extension of the term of an existing 524 MAHRA Housing Assistance Payments Contract renewed under Option One or Option Two of the Section 8 Renewal Policy Guide.

1) The Department will permit a one-time extension of the existing contract term if:

- There is no resetting of contract rents upon execution of the contract extension; and
- Annual rent adjustments and, if applicable, RCS updates adhere to the original anniversary date.

2) Only the term of the existing MAHRA contract is affected by the extension. If the

PM/CA approves the request, the Owner and HUD/CA will sign the HAP Extension form.

c. Attachment 5 has been updated to clarify where the Owner may find where the project's initial equity was computed.

The page changes can be accessed from the Section 8 Contracts website at:
<http://www.hud.gov/offices/hsg/mfh/mfhsec8.cfm#s8rpg>.

MONITORING GUIDE UPDATED

The *Rent and Income Determination Quality Control Monitoring Guide for Multifamily Housing Programs (Guide)* has been updated and is now posted. The Guide can be accessed from HUDCLIPS at <http://www.hud.gov/offices/adm/hudclips/> or from the Multifamily RHIP website at <http://www.hud.gov/offices/hsg/mfh/rhiip/mfhrhiip.cfm>.

This Guide was developed as part of the Rental Housing Integrity Improvement Project (RHIP) effort to reduce errors in income and rent determination and to ensure that the right benefits go to the right persons. The Guide provides guidance to Contract Administrators (HUD staff, Performance Based Contract Administrators (PBCAs), and Traditional Contract Administrators (TCAs)) conducting on-site occupancy monitoring reviews of HUD's assisted multifamily housing.

The Guide now includes guidance and information for monitoring an owner's/agent's (O/A's) compliance and use of the Enterprise Income Verification (EIV) system. While use of EIV is not currently mandatory for O/As administering assisted housing under one of Multifamily Housing's programs, many O/As are using the income information from EIV at the time of recertification of their tenants.

Following is a direct link to the Guide: <http://www.hud.gov/offices/hsg/mfh/rhiip/qcguide.pdf>

For information on obtaining access to the EIV system, visit the Multifamily EIV website at:
<http://www.hud.gov/offices/hsg/mfh/rhiip/eiv/eivhome.cfm>.

TV Goes Digital

How the Federal Government is Helping with the Transition

Multifamily Housing's Office of Housing Assistance and Grant Administration is making the following information available to assist in the Federal effort to alert the public to the digital television transition taking place February 17, 2009. On this date, all full-power broadcast television stations in the United States will begin to broadcast only in digital.

Who will be affected?

For Americans who already own a digital television or subscribe to cable, satellite or other pay service, the transition will have little or no impact. However, more than 13 million U.S. households rely on over-the-air (OTA) broadcasts on their analog television sets exclusively. Consumers who, on average, more exclusively rely on OTA analog TV broadcasts include older Americans, minorities (African American, Hispanic, Asian American, and Native American), rural residents, low-income individuals and people with disabilities. These populations also tend to rely heavily on television to keep them informed in times of emergency and cannot afford to lose their connection to television broadcasts.

Transition Options

U.S. households that rely solely on OTA analog TV for their television viewing need to understand that the transition will occur on February 17, 2009. They must take action before this date in order to continue receiving television broadcasts on their analog TVs. These households have the following options to choose from:

- Buy a converter box that will plug into their analog TV.
- Buy a TV with a digital tuner.
- Connect their analog TV to cable, satellite or other pay service.

Federal Government Coupon Program

For consumers who decide a converter box is their preferred option, the Federal Government is offering U.S. households up to two \$40 coupons to help pay the cost of up to two certified converter boxes. These converter boxes decode the digital signal back to analog for display on analog TV sets, enabling them to keep working after the digital transition.

The TV Converter Box Coupon Program is administered by the U.S. Department of Commerce's National Telecommunications and Information Administration (NITA). Consumers may request coupons between January 1, 2008 and March 31, 2009 through a toll-free customer support center, a Web site, fax, and through the mail. Coupons will be sent to households via U.S. mail and may be redeemed at participating retailers throughout the nation.

What can owners and management agents do?

Owners and management agents of HUD-subsidized multifamily properties can post the attachments to this listserv message and/or distribute them to their residents to provide them with the knowledge needed in preparation for the February 17, 2009, digital TV implementation date. The attachments are as follows:

- Will Your TV Work Next Year?* – Flyer describing transition, if a converter box is needed and converter box coupon details
- Converter Box Coupon Information Application* – For mailing and instructions on how to apply by other methods
- Digital Tips** – Instructions on setting up the converter box

Further information can be obtained from the following website:

www.DTV2009.gov

* Information provided by the U.S. Department of Commerce

** Information provided by www.DigitalTips.org

<<Will Your TV Work Next Year.pdf>> <<Converter Box Coupon Application.pdf>> <<Digital Tips.pdf>>



Will Your TV Work Next Year?



After February 17, 2009, all full-power television stations will broadcast only in digital. If you use rabbit ears or a rooftop antenna with your analog TV, you are going to need to take action to continue watching TV.

What can you do? You have three options:



- You can buy a converter box that will plug into your analog TV;
- You can buy a TV with a digital tuner; or
- You can connect your analog TV to cable, satellite or other pay service.

The Government Will Help



If you decide to buy a converter box, the Federal Government is offering U.S. households up to two \$40 coupons to help pay for the cost of certified TV converter boxes. These certified TV converter boxes are available at participating retailers and are expected to cost between \$40 and \$70.

Have Cable or Satellite?

If all your TV sets are connected to cable, satellite or other pay service, check with your provider to see how they will support your analog set after February 17, 2009.

For more information or to request your coupons, call 1-888-DTV-2009 (1-888-388-2009) or 1-877-530-2634 (TTY), visit www.DTV2009.gov, apply by mail at **PO BOX 2000, Portland, OR 97208 or by fax at **1-888-DTV4ME2 (1888-388-4632)**.**

**Are You Ready for
February 17, 2009?**



**TV Converter Box
COUPON PROGRAM**

www.DTV2009.gov

1-888-DTV-2009



COUPON APPLICATION

All information must be filled out. Please type or print clearly.
This Application is to apply for a \$40 Coupon which can be used towards the purchase of a TV converter box.

TV CONVERTER BOX COUPON PROGRAM

PO Box 2000, Portland, OR 97208-2000

Apply online:

www.DTV2009.gov

Apply by phone:

1-888-DTV-2009 (1-888-388-2009)

Fax applications to:

1-877-DTV-4ME2

Mail applications to:

PO Box 2000,
Portland, OR 97208

TTY: 1-877-530-2634 (English)

1-866-495-1161 (Spanish)

**ALL APPLICATIONS MUST BE
SUBMITTED BY MARCH 31, 2009.**



1. Your Name and Address.

NAME

First

Middle

Last

HOME
ADDRESS

Street Address

Apt #

City

State

Zip

If the US Postal Service does not deliver mail to your Home Address, provide as much information as you can above regarding your Home Address and provide your Mailing Address below.

MAILING
ADDRESS

*If different
than above*

Street Address - or - P.O. Box #

Apt #

City

State

Zip

2. TV Service: Check the statement below that best describes your household.

- All or some of the TVs in my house are connected to one or more pay services, such as cable or satellite.
- None of the TVs in my house are connected to one or more pay services, such as cable or satellite.

3. Coupons Requested: How many coupons do you want?

ONE - OR - TWO

4. Signature: By signing below, you declare that the above is true and correct.

Signature

Date

Set UP Your Digital TV Converter Box: AS EASY AS 1-2-3

If you've decided to buy a Digital TV Converter Box, it's easy to connect the Converter Box to your TV and start enjoying the added features and superior quality of digital television today.

Step 1: Connect the Antenna to your Converter Box

Digital TV works over-the-air just like analog TV – it relies on your TV antenna to receive the transmissions from your local broadcasters. So just disconnect your TV antenna from the TV and connect it to the "Antenna In" jack on your Converter Box.

Step 2: Connect the Converter Box to your old TV

Next, use the cable that came with your Converter Box to connect the "Antenna Out" jack on the Converter to the "Antenna In" jack on your TV set. (If your set and antenna use a flat wire with two terminals to connect, then you'll need inexpensive adapters for both the antenna and for your TV.)

The Converter Box will send the new Digital TV signals to your analog TV on either Channel 3 or Channel 4 (you decide, based on whether or not a local broadcaster is already on that channel.)

Plug your Converter Box into an electrical outlet and insert the batteries that came with the remote control.

Step 3: Turn On, and Tune In

Turn on the Converter Box. Tune your analog TV to the proper input channel (Ch. 3 or 4), and follow the onscreen instructions to do a channel scan. Now you can enjoy your favorite TV programs and new options like local news and weather channels that also come from local broadcasters.

In most cases, Digital TV signals are sent from the same transmission location as analog TV broadcasts. In certain cases, you may find that a different antenna is needed or you might need to re-position your antenna for the best reception of Digital TV signals.

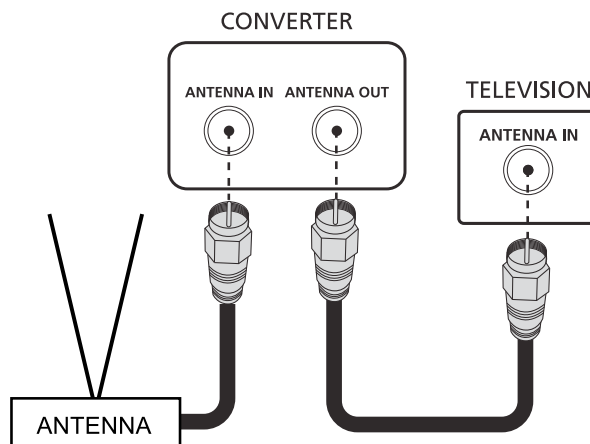

For more information on the Digital TV transition, visit www.DigitalTips.org and www.DTVTransition.org

CHANGE IN OMB REQUIREMENTS FOR THE HUD MODEL LEASES

Please find attached to this Listserv message a memorandum signed by Acting Deputy Assistant Secretary Janet Golrick notifying HUD staff of a change in the Office of Management and Budget (OMB) requirements relative to the HUD model leases used at subsidized properties covered by Handbook 4350.3 REV-1, *Occupancy Requirements of Subsidized Multifamily Housing Programs*. The memorandum also clarifies implementation of the change in the OMB requirements and use of leases that were modified prior to the release of the OMB approved model leases.

The HUD Model Leases Questions and Answers currently posted on the Multifamily RHIIP website are being revised. A Listserv message will be sent out once the revised document has been posted.

Any questions relating to the lease requirements should be addressed to Michael Sharkey at Michael.A.Sharkey@hud.gov or by calling (202) 402-6788.

Summary of guidance on model leases.

HUD (Janet M. Golrick) issued guidance on September 18, 2008, concerning a change in OMB's requirements for the HUD model leases and the implementation of the change. OMB allowed HUD to remove the OMB approval number and expiration date from TRACS or other software generated model leases. The OMB action eliminates the need for Owners/management agents (O/As) to reissue an automatically generated lease when the OMB expiration date changes.

Leases posted on HUDCLIPS will continue to include the OMB expiration date and approval number. O/As who use these leases rather than software generated leases should use the leases for new admissions. Current tenants on a HUDCLIPS lease must only be re-issued a HUDCLIPS lease when required to sign a new lease (e.g., move to a new unit, in which case they would sign the HUDCLIPS lease currently being used for new tenants) or when HUD makes modifications to the lease.

O/As using leases modified prior to the release of the OMB approved model lease may continue to use these leases as long as the modifications have been approved by HUD or the Contract Administrator. O/As can use these modified leases until HUD issues modifications to the language in the lease. Any new lease modifications must be in the form of a lease addendum and approved by HUD or the Contract Administrator. HUD will revise Handbook 4350.3 REV-1 Occupancy Requirements of Subsidized Housing Programs to include the lease addendum requirement.

The guidance also instructs HUD staff, PBCAs and TCAs to not cite O/As if they find that they are using a lease containing modifications approved prior to the release of the OMB approved model lease or are using a lease that does not include the OMB approval number or expiration date. HUD, PBCAs or TCAs should continue to cite O/As for other lease related issues including not using the correct model lease, modifying the lease without HUD or CA approval etc.

Those with questions are referred to Michael Sharkey at 202-402-6788.

**#118 – Systematic Alien Verification for Entitlement (SAVE) Program Users –
(CORRECTION to #117) - September 15, 2008**

NOTE: This is a correction to the Friday, September 12, 2008, posting below in order to correct the spelling of Melosan Bell's name. It is now spelled correctly in the listserv message. If you sent an email to Melosan Bell in response to the listserv message on Friday, September 12, 2008, please resend it to Melosan Bell at the corrected email address below unless you forwarded it to Kevin Garner who, in turn, forwarded it, on your behalf, to Melosan. We apologize for any inconvenience this may have caused.

Attention Systematic Alien Verification for Entitlement (SAVE) Program Users

Starting October 1, 2008, access to the SAVE Program administered by the Department of Homeland Security to verify the immigration status of applicants for and tenants in HUD's rental assistance programs will be limited to the web-based system. Access via PC-1 and PC-2 will no longer be available. All users who have been accessing the SAVE Program via PC – 1 and PC – 2 must register with the Department of Housing and Urban Development for an ID and temporary password to the web-based SAVE Program as soon as possible to avoid being denied access on October 1st.

The following information must be provided:

- Full name of the user
- Complete name and street address of the management agency/property
- Phone number
- Fax number
- HUD Contract Number(s) for each property

For users of the SAVE Program for *Multifamily's Rental Assistance Programs*, please email the above information to Kevin Garner at: Kevin.X.Garner@HUD.gov.

For users of the SAVE Program for the *Public Housing, Housing Choice Voucher and Section 8 Project-Based Certificate Programs*, please email the above information to Melosan Bell at: Melosan.Bell@HUD.gov.

For general technical information, please call the Department of Homeland Security, Technical Assistance line at: 800-741-5023.

**#117 – Systematic Alien Verification for Entitlement (SAVE) Program Users –
September 12, 2008**

Attention Systematic Alien Verification for Entitlement (SAVE) Program Users

Starting October 1, 2008, access to the SAVE Program administered by the Department of Homeland Security to verify the immigration status of applicants for and tenants in HUD's rental assistance programs will be limited to the web-based system. Access via PC-1 and PC-2 will no longer be available. All users who have been accessing the SAVE Program via PC – 1 and PC – 2 must register with the Department of Housing and Urban Development for an ID and temporary password to the web-based SAVE Program as soon as possible to avoid being denied access on October 1st.

The following information must be provided:

- Full name of the user
- Complete name and street address of the management agency/property
- Phone number
- Fax number
- HUD Contract Number(s) for each property

For users of the SAVE Program for *Multifamily's Rental Assistance Programs*, please email the above information to Kevin Garner at: Kevin_X_Garner@HUD.gov.

For users of the SAVE Program for the *Public Housing, Housing Choice Voucher and Section 8 Project-Based Certificate Programs*, please email the above information to Melason Bell at: Melason.Bell@HUD.gov.

For general technical information, please call the Department of Homeland Security, Technical Assistance line at: 800-741-5023.

#116 – Multifamily Help Desk; and EIV Fix 8.1.1 Release; and RHIP Tip (Termination of Assistance) – September 9, 2008

Multifamily Help Desk & EIV System Update

HUD's Multifamily Help Desk

HUD's Multifamily Help Desk is currently experiencing problems with its voicemail system. It cannot receive or retrieve voicemails left from users calling for technical assistance concerning the following multifamily housing systems:

1. Active Partners Performance System (APPS)
2. Development Application Processing (DAP)
3. Enterprise Income Verification (EIV)
4. Real Estate Management System (REMS)
5. Tenant Rental Assistance Certification System (TRACS)

Please also note that unanswered calls to the Multifamily Help Desk ring only four times on the receiving end, after which, the call is disconnected.

HUD's telecom group was notified of the problem yesterday, September 08, 2008. The Department has been informed that the voicemail system is under repair. Once repaired, another Listserv message will be posted to update system users.

EIV Fix 8.1.1 Release

On June 06, 2008, a message was posted to this Listserv informing EIV system users of problems associated with the electronic submission of Coordinator Access Authorization Form (CAAF) and User Access Authorization Form (UAAF) requests for EIV access. It also indicated benefit and wage-related information, including Social Security (SS), Supplemental Security Income (SSI), wage, unemployment compensation, and new hires (W-4) information would be unavailable for tenants **not receiving** Section 8, Rental Assistance Payments (RAP), or Rent Supplement at Section 236 and 221(d)(3) BMIR properties. The date by which such problems were to be corrected was September 22, 2008.

This is to inform you that the date by which identified problems will be corrected has been moved to **October 27, 2008**. For detailed information on the problems and interim solutions, please see the **EIV System Update for Multifamily Housing Program Users** web page at: <http://www.hud.gov/offices/hsg/mfh/rhiip/eiv/sysupdates.cfm>

We apologize for the delay, and thank you for your interest in HUD's EIV system for multifamily housing programs.

RHIP Tip: Termination of Assistance

Assistance must be terminated if a tenant fails to move to a different-sized unit within 30 days after the owner notifies him/her that the unit of the required size is available. If the tenant remains in the same unit, the tenant must pay the market rent, full contract rent, or 110% of the BMIR rent, as required by the HUD lease.

NOTE: When assistance is terminated for a tenant with more than one form of subsidy, the tenant must pay the market rent, full contract rent, or 110% of BMIR rent. For example, if a tenant resides in a Section 236 property and receives Section 8 assistance,

the tenant would pay rent based on the Section 236 rent formula if his or her Section 8 assistance were terminated.

Please refer to Chapter 8, Paragraph 8-5 of HUD Handbook 4350.3 REV-1, *Occupancy Requirements of Subsidized Multifamily Housing Programs*, for further information and additional circumstances when a tenant's assistance must be terminated.

#115 – Students with Disabilities, Notice H08-05 (Economic Stimulus Payments), Guidelines on Mark-to-Market (M2M) in Transfer of Physical Assets and Refinance Transactions, Number of RHIIP Listserv Subscribers; and RHIIP Tip (Income of Students Receiving Section 8 Assistance) - August 25, 2008

Students with Disabilities

The Final Rule that makes a conforming amendment to HUD's regulation that restricts individuals enrolled at an institution of higher education from receiving Section 8 assistance was published in the August 21, 2008 Federal Register. This conforming amendment exempts from the restrictions, students with disabilities who were receiving Section 8 assistance as of November 30, 2005. The Final Rule is posted on HUDCLIPS at <http://edocket.access.gpo.gov/2008/pdf/E8-19435.pdf>.

Exclusion of Economic Stimulus Payments

Notice H 08-05 was issued on August 18, 2008, addressing the exclusion of the Economic Stimulus payments (tax rebates) received by applicants and tenants participating in HUD's rental assistance programs. The Notice is posted on HUDCLIPS at <http://www.hud.gov/offices/adm/hudclips/notices/hsg/files/08-05HSGN.doc>.

Guidelines for Assumption, Subordination, or Assignment of Mark-to-Market (M2M) Program Loans in Transfer of Physical Assets (TPA) and Refinance Transaction

Notice H 08-04 was issued on July 31, 2008, providing guidance that outlines a request process and review criteria for owners who wish to refinance or sell a property that has received the benefits of a debt restructuring under M2M under the conditions outlined in the Notice. The Notice is posted on HUDCLIPS at <http://www.hud.gov/offices/adm/hudclips/notices/hsg/files/08-04HSGN.doc>.

GOOD NEWS

As of August 14, 2008, there were **6,000** subscribers to the Multifamily Housing RHIIP (Rental Housing Integrity Improvement Program) Tips Listserv. HUD encourages its Multifamily business partners to sign up for the Listserv in order to receive up-to-date information and guidance on the Multifamily Housing programs. If you know of someone who could benefit from the Listserv messages, please provide them with the information below on how to subscribe.

To subscribe:

Log into www.hud.gov

Scroll down and under Tools, select "Mailing Lists"

Scroll down and select "Multifamily Housing RHIIP (Rental Housing Integrity Improvement Program Tips):

Complete the information requested and click on "OK"

You will receive an email message asking you to confirm your registration. Once you confirm your registration, you will begin receiving the Multifamily Listserv messages.

RHHP Tip: Income of Students Receiving Section 8 Assistance

For students receiving Section 8 assistance, all financial assistance a student receives (1) under the Higher Education Act of 1965, (2) from private sources, or (3) from an institution of higher education that is in excess of amounts received for tuition is included in annual income except if the student is over the age of 23 with dependent children or the student is living with his or her parents who are receiving Section 8 assistance. See Paragraph 3-13 for further information on eligibility of students to receive Section 8 assistance and the Glossary for the definition of Student Financial Assistance.

For more information on income of students receiving Section 8 assistance, please refer to Chapter 5, Paragraph 5-6.D of HUD Handbook 4350.3 REV-1 *Occupancy Requirements of Subsidized Multifamily Housing Programs*.

Enterprise Income Verification (EIV) System

Advisory Notice for Multifamily Housing Program Users

On April 24, 2008, the Department sent an email to contract administrators, including performance based contract administrators (PBCAs) and traditional contract administrators (TCAs), informing them that their EIV roles needed to be converted from HSC to CAC or HSU to CAU for security and tracking related purposes, and the Department gave them instructions on how to accomplish that. Although the email was restricted to CAs, some CAs misunderstood the email and thought that owners and management agents (O/As) had to have their roles converted too, so they informed their O/As that they too needed to have their roles converted from HSC to CAC or HSU to CAU, and instructed them on how to accomplish this. Consequently, some O/As had their roles converted at their CA's instruction, resulting in EIV system errors and problems for these O/As.

When made aware of this, on July 21, 2008, the Department sent another email to CAs asking them to notify O/As who were told they needed to have their roles converted from HSC to CAC or HSU to CAU and instructed them to send identifying information to Kevin Garner at Kevin_X._Garner@hud.gov to have their roles converted back to the appropriate HSC or HSU role. Specifically, the email is to include the below O/A information:

- * First Name
- * Last Name
- * M-ID
- * Current EIV Role (CAC or CAU role)
- * Identification (Owner or Management Agent)
- * Email address

Some O/As are following the above instructions to have their EIV role converted from CAC or CAU back to the appropriate HSC or HSU role. However, the Department has been informed that some O/A Coordinators are either contacting HUD's Multifamily Helpdesk to make the role conversion from CAC back to HSC or attempting to perform the role conversion themselves and then contacting HUD's Multifamily Helpdesk by phone or email or submitting an electronic Coordinator Access Authorization Form (CAAF) request for certification or recertification to HUD's Multifamily Helpdesk to process. **O/As should not be contacting HUD's Multifamily Helpdesk to make the role conversion or attempting to make the role conversion themselves, as O/As are prohibited from assigning EIV access rights to themselves**, as indicated in several prior RHIIP Listserv Messages and established in the "External (Non-HUD Coordinator/User) Instructions for Applying for EIV Access for Multifamily Housing Programs," located at: <http://www.hud.gov/offices/hsg/mfh/rhiip/eiv/applyforeivaccess.pdf>.

If you are an O/A who currently has the CAC or CAU role assigned to your contract(s) and/or property(ies) in WASS, but you should have the HSC or HSU role assigned to your contract(s) and/or property(ies) in WASS and be certified in EIV with the appropriate role, please follow the above instructions and email Kevin Garner with the specified information to have your role converted the from CAC or CAU back to the appropriate HSC or HSU role.

If you are an O/A and have questions concerning this RHIP Listserv Message, please contact Kevin Garner via email at: Kevin_X._Garner@hud.gov or by phone at: 202/402-2057 for assistance.

We apologize for the confusion and thank you for your continued cooperation and interest in HUD's EIV System for Multifamily Housing Programs.

Page Change issued to the Section 8 Renewal Policy Guide July 18, 2008

Explanation of Change

The instructions contained in the note at the top of page 2 in Chapter 14, dealing with renewals of 524(b) projects has been corrected. The words “and subsequent renewal” have been added so that RHS projects like all other 524(b) projects are subject to the “lesser of” test at both initial and subsequent renewal.

The material is posted on the web at: <http://www.hud.gov/offices/hsg/mfh/mfhsec8.cfm>

RHIIP Tip: Interim Recertifications

In cases where an owner has confirmation that a tenant's income will be partially changed and restored within two months, owners may delay, but not refuse, to process an interim recertification. Processing may be delayed only until the new income is known.

For more information on delaying the processing of an interim recertification and the steps to follow once the new income is known, please refer to Chapter 7, Paragraph 7-11.F of HUD Handbook 4350.3 REV-1 *Occupancy Requirements of Subsidized Multifamily Housing Programs*.

Quality Control for Rental Assistance Subsidies Determination: Final Report for FY 2006 Recently Release

HUD's Office of Policy Development and Research (PD&R) recently released the *Quality Control for Rental Assistance Subsidies Determination: Final Report for FY 2006*. This study measures administrator rent calculation and processing errors made by housing providers during FY 2006 (October 2005 through September 2006). National estimates of the extent, severity, costs, and sources of rent errors in determining tenant subsidies are calculated for the following programs:

- Public Housing;
- Section 8 Housing Choice Voucher;
- Section 8 Moderate Rehabilitation;
- Project-based Section 8;
- Section 202 and Section 811 Project Rental Assistance Contract (PRAC); and
- Section 202/162 Project Assistance Contract (PAC).

The full report is available as a free download from HUD USER at www.huduser.org/publications/pubasst/QC_fy06.html.

Previous *Quality Control for Rental Assistance Subsidies Determinations* reports are also available as downloads from HUD USER free of charge at huduser.org/publications/pubasst.html.

#111 – EIV Instructional Course Cancellation – July 7, 2008

ATTENTION: ENTERPRISE INCOME VERIFICATION (EIV) SYSTEM WEBCAST

SCHEDULED FOR JULY 8-9, 2008 IS CANCELLED

The webcast scheduled for July 8-9, 2009, is cancelled. We apologize for any inconvenience this has caused and will send out another listserv message as soon as the webcast is rescheduled.

CELEBRATING 30 YEARS OF INDEPENDENCE

HUD’s Congregate Housing Services Program (CHSP) was created as a demonstration program in 1978 and was among the first initiatives developed by the Federal Government to provide a comprehensive housing and supportive services package within a subsidized housing environment. Supportive services eligible under the CHSP are those which assist the frail elderly, non-elderly people with disabilities, and temporarily disabled individuals to live independently and prevent premature or unnecessary Institutionalization.

Over the last 30 years, CHSP funds have enabled tens of thousands of low-income elderly individuals and people with disabilities to enjoy a quality of life and to achieve a degree of independence that would otherwise not have been possible. Today, there are 51 public housing agencies and private assisted housing owners administering 63 grants under the CHSP program that have been in operation from 13 to 29 years. Each year Congress appropriates new funds to extend existing programs - assuring that the frail elderly and people with disabilities can count on continuation of the valuable services they receive.

To celebrate CHSP’s 30th anniversary, HUD has created a set of web pages highlighting existing CHSP programs. Grantees were asked to send in a description of their program along with photos. Here’s what some had to say when they submitted their contribution:

“Happy Birthday CHSP! Our program means so much to life here at Juniper Hill Village.”

“We are indeed happy that we have been able to participate in this program for many years. We certainly look forward to providing these services with this grant for many years to come.”

“Thank you for inviting us to participate, we have benefited from this extraordinary service for almost the entire time it has been in existence.”

“It is difficult to say what needs to be said in just a few words because there are so many good things to say about this program.”

“Congratulations to all for continuing this worthwhile and so needed program!”

To learn more about the CHSP and existing CHSP grantee organizations, please visit the CHSP anniversary page at <http://www.hud.gov/offices/hsg/mfh/progdesc/chsp/chsp.cfm>.

#109 – Issuance of Notice H2008-03 (EIV System); HUD Model Lease Q&A's; and Correction to Student Eligibility Restrictions Q&A – July 3, 2008

Issuance of Notice H 2008-03 - Enterprise Income Verification (EIV) System

Housing Notice H 2008-03 on using the data in the EIV system was issued on June 25, 2008 and is now posted on HUDCLIPS at: <http://www.hud.gov/offices/adm/hudclips/notices/hsg/files/08-03HSGN.doc>

This Notice provides guidance to owners and management agents (O/As) on using the data in EIV for verifying, at the time of recertification, the employment and income of individuals participating in one of Multifamily Housing's rental assistance programs. Although use of the EIV system is not mandatory at this time, HUD encourages O/As to get access to EIV and use the data in EIV as it will assist in reducing errors in determining a tenant's income, thereby reducing the number of improper payments in Multifamily Housing's rental assistance programs.

HUD Model Leases Questions and Answers

New Question added:

Question 33: How should the lease term be completed when the tenant has fulfilled the initial one year term and is now on a month-to-month lease?

Answer 33:

HUD Model Lease for Subsidized Programs, Form HUD-90105-a, paragraph 1 should be completed by inserting the beginning and ending day of the month the lease is issued to the tenant. The "initial" term in this case is for one month. The successive term would be for a "month". For example, if the lease is issued on July 1, 2008 paragraph 1 would read as follows:

1. The initial term of this Agreement shall begin on July 1, 2008 and end on August 1, 2008. After the initial term ends, the Agreement will continue for successive terms of one month each unless automatically terminated as permitted by paragraph 23 of this Agreement.

HUD Model Leases for Section 202/8 or Section 202 PACs, Section 202 PRACs and Section 811 PRACs, HUD Forms 90105-b, c and d, respectively, will require a lease addendum modifying paragraph 1 of the leases indicating the month to month lease term. If the addendum only includes modification to paragraph 1 of the lease, the addendum does not have to be approved by the HUD Field Office or Contract Administrator. See Question 30 for additional information on modifications to the lease that were previously approved by the HUD office of CA.

Question 31 revised:

Question 31: What do we do with properties using leases provided by the contract administrator (CA)? Some states have significantly different lease requirements and CAs have developed leases that O/As are required to use. Will the CAs instruct the O/As to use the HUD model leases and the CA will then provide an approved lease addendum?

Answer 31: O/As should be using the HUD model leases and not leases developed by CAs. HUD model leases that have been modified to include state requirements will now have to have the state requirements incorporated by use of a lease addendum. Whether or not the CA will provide the approved lease addendum or whether it will be up to the O/A to develop, we cannot answer. Normally it is the O/A's responsibility to ensure that the lease is in compliance with state laws.

However, for projects financed by a State Agency and under the jurisdiction of a Traditional Contract Administrator (TCA), the O/A will continue to use the lease provided by the State

Agency as addressed in paragraph 6-5 A.2 of Handbook 4350.3 REV-1, *Occupancy Requirements of Subsidized Multifamily Housing Programs*.

**A complete listing of the HUD Model Leases Questions and Answers that include the above information is posted on the Multifamily RHIP website at:
<http://www.hud.gov/offices/hsg/mfh/rhiip/mfhrhiip.cfm>**

Correction to Student Eligibility Restrictions Question and Answer

A correction to the Code of Federal Regulation (CFR) reference in the answer to the question relative to the Federal Mandated Exclusion in income has been made as follows:

Federally Mandated Exclusion	How does 5.609(b)(9) affect the Federally mandated exclusion of "Amounts of scholarships funded under title IV of the Higher Education Act of 1965, including awards under federal work-study programs or under the Bureau of Indian Affairs student assistance programs (20 U.S.C. 1087uu)?	The Federally mandated exclusion under 24 CFR 5.609(c)(17) does not apply to individuals applying for or receiving Section 8 assistance. The Federally mandated exclusion continues to be in effect for other Multifamily Housing programs.
------------------------------	--	---

IMPORTANT REMINDER
FOR ALL MULTIFAMILY HOUSING ENTERPRISE INCOME
VERIFICATION (EIV) SYSTEM USERS
EIV 8.1 INSTRUCTION COURSE ANNOUNCEMENT

Don't forget to tune in to the in-depth, two-day EIV instructional course.

Course Date: July 8 and 9, 2008

Course Hours: 11:00 a.m. – 4:00 p.m. (Eastern Time Zone)

Delivery Method: Via HUD Web cast at <http://www.hud.gov/webcasts/index.cfm>.

Owners and management agents (O/As), contract administrators and HUD staff are invited to attend the course. The course will be delivered by HUD Headquarters staff and will provide information on gaining and retaining EIV access, security of EIV data, using EIV information and reports and monitoring compliance of O/As using the EIV system. The revised agenda for the scheduled course is attached.

Prior to the course, the course materials, including Power Point presentations and case studies, will be posted to the **EIV Training and Outreach for Multifamily Housing Programs** web page at <http://www.hud.gov/offices/hsg/mfh/rhiip/eiv/eivtraining.cfm> for review and downloading.

Questions concerning the instructional course should be directed to Kevin Garner, Housing Program Manager, who can be reached by telephone at (202) 402-2057 or by email at Kevin.X.Garner@hud.gov.

HUD MODEL LEASES

QUESTIONS AND ANSWERS

Since the May 15, 2008, release of the HUD Model leases that contain a HUD form number, OMB approval number, OMB expiration date and public reporting burden information, we have received numerous questions relating to the use and implementation of the leases. In order to ensure that everyone has access to consistent answers, the Department is providing the attached list of questions and answers. The HUD Model Leases Questions and Answers document is also posted on the Multifamily RHIP website at:

<http://www.hud.gov/offices/hsg/mfh/rhip/mfhrhip.cfm>.

Attention All Enterprise Income Verification (EIV) System Users for Multifamily Housing Program Users - EIV 8.1 Instructional Course Announcement

The Department is excited to announce another in-depth, two-day EIV instructional course that will be conducted July 8 and 9, 2008, via HUD Webcast at:

<http://www.hud.gov/webcasts/index.cfm>. Owners and management agents (O/As), contract administrators (CAs) and service bureaus are invited to attend the course, delivered by HUD staff. As with the June 2007 course, HUD staff will deliver an informative slide presentation ranging from gaining and continuing EIV access, reading income information and verification reports, to monitoring O/A activities, as the Department moves to mandate the use of EIV for multifamily housing programs. See attached agenda for the scheduled course. Course materials, including Power Point presentations and case studies will be posted to the **EIV Training and Outreach for Multifamily Housing Programs** web page at:

<http://www.hud.gov/offices/hsg/mfh/rhiip/eiv/eivtraining.cfm> prior to the course for review and download.

Questions concerning the instructional course should be directed to Kevin Garner, Housing Program Manager, who can be reached by telephone at 202/402-2057 or by email at Kevin_Garner@hud.gov.

Thank you for your interest in HUD's EIV system and for assisting the Department to further reduce income and rent determination errors through use of the EIV system.

<<EIV Course Agenda.doc>>



Enterprise Income Verification (EIV) System (8.1) for Multifamily Housing Programs

Instructional Course Agenda

Date: July 8-9, 2008

Time: 11:00AM - 4:00PM Eastern Standard Time (EST)

Location: HUD Webcast: <http://www.hud.gov/webcasts/index.cfm>

HUD Presenters: Gail Williamson, Director, Housing Assistance Policy Division
LaDonna Reed-Morton, Housing Program Manager
Diane Hooten, Housing Program Manager
Kevin Garner, Housing Program Manager
Yvette Viviani, Housing Program Manager

EIV Training and Outreach for Multifamily Housing Programs Web Page for Materials: <http://www.hud.gov/offices/hsg/mfh/rhiip/eiv/eivtraining.cfm>

DAY ONE (11:00 – 4:00)

11:00 – 11:15: Opening Remarks (Presenter: Gail Williamson)

- Welcome
- Course objectives
- Course schedule
- Presenters

11:15 – 12:10: Gaining/Continuing EIV Access (Presenter: Kevin Garner)

- EIV Roles (*External Users Only*)
- Hardcopy Coordinator Access Authorization Form (CAAF) submissions to HUD's Multifamily Helpdesk
- Hardcopy User Access Authorization Form (UAAF) submissions to EIV Coordinators
- Electronic CAAF submissions to HUD's Multifamily Helpdesk
- Electronic UAAF submissions to EIV Coordinators

12:10 – 12:30: Question & Answer (Q&A) Session

12:30 – 1:30: Lunch

1:30 – 2:15: Gaining/Continuing EIV Access *Cont'd* (Presenter: Kevin Garner)

- User Administration (*EIV Coordinators Only*)

2:15 – 2:45: Security Measures (Presenter: Diane Hooten)

- Technical safeguards
- Administrative safeguards

- Physical safeguards
- Security Awareness Training Questionnaire
- Contact for security breaches

2:45 – 2:55: Break

2:55 – 3:40: EIV Modules (Presenter: Diane Hooten)

- Income Information
- Verification Reports
- Coordinator Access Request
- User Access Request

3:40 – 3:55: Q&A Session

3:55 – 4:00: Closing Remarks (Presenter: Gail Williamson)

DAY TWO (11:00 – 4:00)

11:00 – 11:15: Opening Remarks (Presenter: Gail Williamson)

- Welcome
- Recap of DAY ONE
- DAY TWO course schedule
- Presenters

11:15 – 12:00: EIV Income Information Reports (Presenter: LaDonna Reed-Morton)

- Income Report

12:00 – 1:00: Lunch

1:00 – 2:15: EIV Income Information Reports *Cont'd* (Presenter: LaDonna Reed-Morton)

- Income Discrepancy Report

2:15 – 2:35: Q&A Session

2:35 – 2:45: Break

2:45 – 3:15: EIV Income Information Reports *Cont'd* (Presenter: Yvette Viviani)

- Failed Verification Report
- No Income Report
- New Hires Report

3:15 – 3:50: Monitoring – Contract Administrators (CAs) and HUD Staff Only (Presenter: Yvette Viviani)

- Form HUD-9834, *Management Review for Multifamily Housing Projects*
- Impending Final Rule, *Refinement of Income and Rent Determination Requirements in Public and Assisted Housing Programs*
- Form HUD 9887, *Notice and Consent for the Release of Information*
- Review of EIV approval forms
- Owner and Management Agent (O/A) EIV-related policies and procedures
- EIV data record retention

3:50 – 4:00: Closing Remarks

Attention Enterprise Income Verification (EIV) System Users for Multifamily Housing Programs - EIV System Update!

The Department has identified problems associated with the electronic submission of Coordinator Access Authorization Form (CAAF) and User Access Authorization Form (UAAF) requests for EIV access. In addition, benefit and wage-related information, including Social Security (SS), Supplemental Security Income (SSI), wage, unemployment compensation, and new hires (W-4) information is currently unavailable in EIV for tenants **not receiving** Section 8, Rental Assistance Payments (RAP), or Rent Supplement at Section 236 and 221(d)(3) BMIR properties. All of these problems should be corrected by **September 22, 2008**. For detailed information on the problems and interim solutions, please see the **EIV System Update for Multifamily Housing Program Users** web page at: <http://www.hud.gov/offices/hsg/mfh/rhiip/eiv/sysupdates.cfm>

Thank you for your patience and for your interest in HUD's EIV system.

USING ENTERPRISE INCOME VERIFICATION (EIV) SOCIAL SECURITY INCOME INFORMATION AS THIRD PARTY VERIFICATION

When a tenant reports that he/she is receiving Social Security (SS) or Supplemental Security Income (SSI) benefits and the benefit amount he/she reports receiving agrees with the benefit information in EIV, the owner does **not** need to request that the tenant provide a copy of his/her benefit award letter provided by the Social Security Administration (SSA) or other documentation to supplement the EIV data. **The EIV Income Report containing the SSA benefit information may be used as third party verification.**

For example:

If the tenant reports his/her social security check/deposit is \$600 and he/she pays the Medicare premium and the EIV benefit information supports that the net social security benefit amount paid to the tenant is \$600 and that the tenant pays the Medicare premium, then the owner can use the EIV Income Report as third party verification. The owner/agent will use the **gross** benefit amount from the EIV Income Report for determining the tenant's annual income and **will include** the cost of the Medicare premium as a medical expense.

If the tenant reports his/her social security check/deposit is \$600 and he/she does not pay the Medicare premium and the EIV benefit information supports that the gross and net social security benefit amount paid to the tenant is \$600 and there is a "Y" in the Buy-in column, then the owner can use the EIV Income Report as third party verification. The owner/agent will use the **gross** benefit amount from the EIV Income Report for determining the tenant's annual income and will **not** include the cost of the Medicare premium as a medical expense.

Whenever the SS/SSI benefit information in EIV does not agree with what the tenant reports; when the tenant disputes the SS/SSI benefit information in EIV; or, there is no SS/SSI benefit information in EIV, the owner must obtain third party verification, as discussed in HUD guidance, **"Resolving Income Discrepancies between Tenant-Provided and Enterprise Income Verification (EIV) System Income Data,"** located on the Enterprise Income Verification (EIV) System for Multifamily Housing Programs website at:
<http://www.hud.gov/offices/hsg/mfh/rhiip/eiv/eivhome.cfm>.

Multifamily Help Desk for the Enterprise Income Verification (EIV) System

Service Restored

Effective May 19, 2008, the service of the Multifamily Help Desk for EIV has been restored.

Therefore, the Help Desk can now be contacted again by telephone at 1-800-767-7588 or by email at Mf_eiv@hud.gov. The Help Desk is working on a backlog of inquiries, and will be responding to them in the order in which they were received. Please be patient while the Help Desk returns to normal operations and works through the backlog. Again, we apologize for any inconvenience the temporary interruption in service may have caused.

#102 – Update on HUD Forms (50059, Model Leases, 9887/9887-A, 27061-H, 90100, 90101, 90102, 90103, 90104 & 90106) – May 19, 2008

FORM NUMBERS, OMB APPROVAL NUMBERS AND OMB EXPIRATION DATES ASSIGNED TO FORMS FROM HANDBOOK 4350.3 REV-1

The following forms from Handbook 4350.3 REV-1, *Occupancy Requirements of Subsidized Multifamily Housing Programs*, have now been assigned HUD form numbers, OMB approval and/or OMB expiration dates. **There are no changes to the language in any of the forms other than the addition of the public reporting burden paragraph.** The forms are now posted on HUDCLIPS at <http://www.hud.gov/offices/adm/hudclips/> . Not all forms are currently available in a pdf fillable format at this time, but will be soon.

HUD-50059, *Owners Certification of Compliance with HUD's Tenant Eligibility and Rent Procedures* - new OMB expiration date

Effective Date: Until such time as the O/A's computer software is updated to incorporate the new expiration date on the HUD-50059, after printing out the form HUD-50059 from their software, O/As must cross out the old expiration date and write in the new expiration date of 3/31/2011. The expiration date should be changed prior to obtaining tenant signatures. If for any reason the O/A does not use a computer generated form as the certified/signed HUD-50059, the O/A must use the form HUD-50059 posted on HUDCLIPS that includes the revised OMB expiration date of 3/31/2011.

HUD Model Leases

Assigned HUD form number, OMB approval number and OMB expiration date

- HUD-90105a – Exhibit 4-A, Model Lease for Subsidized Programs (Family Model Lease)
- HUD-90105b – Exhibit 4-B, Model Lease for Section 202/8 or Section 202 PAC
- HUD-90105c – Exhibit 4-C, Model Lease for Section 202 PRAC
- HUD-90105d – Exhibit 4-D, Model Lease for Section 811 PRAC

NOTE: The four HUD model leases are currently posted on HUDCLIPS under form HUD-90105-A – we are working on getting them separated into four separate documents.

Effective Date: O/As must begin using the new HUD Model Leases **for all new admissions immediately and for existing tenants beginning with annual recertifications effective January 1, 2009, or later.** Because forms that have OMB approval and OMB expiration dates cannot be modified, O/As who have lease modifications will need to develop lease addendums to incorporate the lease modifications. O/As who have had lease modifications approved by HUD or the Contract Administrator do not have to have the lease modifications included on the lease addendums approved again prior to implementation. Only if the O/A has obtained approval from HUD or the Contract Administrator to incorporate additional lease modifications must the O/A provide notice to the tenants in accordance with Chapter 6, Paragraph 6-12 D of Handbook 4350.3 REV-1.

HUD-9887/HUD-9887-A, Consent forms – reposted – inclusion of OMB Approval Number/Expiration date on the forms not required because it is not considered an information collection

Effective Date: O/As must continue to use these forms for new admissions and at annual recertification.

HUD-27061-H - Exhibit 4-3 – Race & Ethnic Data Reporting Form – **new OMB expiration date**

Effective Date: O/As must begin using this form immediately for new admissions and, when applicable, at the time of a tenant's interim or annual recertification.

Sample Forms

Assigned HUD form number, OMB approval number and OMB expiration date

- **HUD-90100** – Exhibit 7-1 – Sample Initial Notice
- **HUD-90101** – Exhibit 5-4 – Sample Certification for Qualified Long-Term Care Insurance Expenses
- **HUD-90102** – Appendix 6-B – Sample Verification of Disability When Eligibility for Admission or Qualification for Certain Income Deductions is Based on Disability – Section 202/8, Section 202 PAC, Section 202 PRAC and Section 811 PRAC
- **HUD-90103** – Appendix 6-B – Sample Verification of Disability When Eligibility for Admission or Qualification for Certain Income Deductions is Based on Disability – For use with all programs Except Section 202/8, Section 202 PAC, Section 202 PRAC and Section 811 PRAC
- **HUD-90104** – Exhibit 3-1 – Sample Request for Exception to Limitations on Admission of Families with Incomes Above 50% of the Area Median Income
- **HUD-90106** – Appendix 5, Sample Move-in/Move-Out Inspection Form

Effective Date: O/As using the sample forms listed above without any changes or modifications must begin using the forms immediately.

O/As not using the sample forms provided above and who have developed their own modified forms are not required to use the forms as posted on HUDCLIPS but may continue to use the forms they have developed. The modified forms they have developed **must not** include the HUD form number, OMB approval number or OMB Expiration date or Public reporting burden language. O/As must follow the guidance in Appendix 6-A of Handbook 4350.3 REV-1 for development of individual consent forms.

A New Funding Opportunity from HUD

On Friday, April 25, 2008 the Notice of Funding Availability (NOFA) for the **Demonstration Program for Elderly Housing for Intergenerational Families** in the amount of \$3.96 million was published in the Federal Register volume 73, number 81. Applications are due July 2, 2008. Information can be obtained on the federal grant source website <http://www.grants.gov>. It is crucial for applicants to register early to ensure that they have an opportunity to compete for these funds.

Eligible Applicants

This opportunity is open to all private nonprofit owners of Section 202 Supportive Housing for the Elderly projects.

Satellite Broadcast

There will be a live satellite broadcast with questions and answers on applying for the Demonstration Program for Elderly Housing for Intergenerational Families on May 20, 2008 at 3:30pm. You may access the broadcast via satellite at your local Field Office or by using the following satellite coordinates: AM-1 (c-band), Transponder 9, Channel 9, 3880 MHz Horizontal, 103 degrees W. Longitude. The broadcast will also be transmitted through the internet. For more information, please see the grants page of the HUD website www.hud.gov.

Purpose

The purpose of this demonstration program is to provide affordable rental housing for intergenerational families. Using capital advance and project rental assistance contracts, this demonstration will expand the supply of affordable housing for very low-income grandparents or relatives who are heads of household 62 years of age or older raising a child. The program is managed through the Office of Housing Assistance and Grant Administration in the Office of Housing and will benefit very low income seniors and their families.

Background

The demonstration program originates from the Legacy Act of 2003, which also required HUD to conduct a study with the Census Bureau on intergenerational housing needs; and to carry out training for federal employees who, through no fault of their own, may be misinterpreting policies that affect the grandparent- and other relative-headed families. To view the webcast of the training, follow this link to HUD webcast archives:
<http://hudatwork.hud.gov/services/webcasts/multifamily.cfm>

To read the study, use this link for PD&R's website:
http://www.huduser.org/publications/affhsg/int_genrtnl.html.

For further questions on the demonstration program, please contact Claire Trivedi (202) 402-6634.

**Attention All Enterprise Income Verification (EIV) Users for
Multifamily Housing Programs**

The problems identified in the listserv message sent out earlier today (posting #99) have all been corrected. All reports and data are now available. Again, we apologize for any inconvenience this caused and we thank you for your patience.

RHIP Tip: Methods for Projecting and Calculating Annual Income

The requirements for determining whether a family is eligible for assistance, and the amount of rent the family will pay, require the owner to project or estimate the annual income that the family expects to receive. There are several ways to make this projection. The following are two acceptable methods for calculating the annual income anticipated for the coming year:

1. Generally the owner must use current circumstances to anticipate income. The owner calculates projected annual income by annualizing *current* income. Income that may not last for a full 12 months (e.g., unemployment compensation) should be calculated assuming current circumstances will last a full 12 months. If changes occur later in the year, an interim recertification can be conducted to change the family's rent.
2. If information is available on changes expected to occur during the year, use that information to determine the total *anticipated* income from all known sources during the year. For example, if a verification source reports that a union contract calls for a 2% pay increase midway through the year, the owner may add the total income for the months before, and the total for the months after the increase.

For further information, please refer to Chapter 5, Section 1, Paragraph 5-5.A of HUD Handbook 4350.3 REV-1 *Occupancy Requirements of Subsidized Multifamily Housing Programs*.

**Attention All Enterprise Income Verification (EIV) Users for
Multifamily Housing Programs**

EIV System Failure Alert!

Due to problems experienced with the EIV system over the weekend, users will notice the following:

- For options to search by Subsidy Contract or to search by Project Number, under **Income Information** in EIV, reports have been deleted and no information is available online for reports under these links in EIV.
- All Reports under **Verification Reports** in EIV are also not available at this time.
- Users can obtain summary and detailed tenant information through the search by Head of Household option in EIV; but the income discrepancy report information is not available at this time.

HUD is actively working to correct the problems and apologizes for any inconvenience this has caused. Another listserv message will be posted once the problems have been corrected.

EIV System Enhancements

On May 12, 2008, the newly enhanced EIV 8.1 System for Multifamily Housing Programs became available. System enhancements include, but are not limited to:

- the ability for External users to assign multiple EIV roles to their User ID and contract(s) and/or property(ies) in Web Access Secure Systems (WASS);
- a new “Failed Pre-screening Report,” accessible via the “Identify Verification Report,” that identifies tenants for a selected contract(s) and/or property(ies) whose personal identifiers were not sent to the Social Security Administration (SSA) for verification because they failed the EIV pre-screening test;
- identifying user information (M-ID and First and Last Name) on all of the printable reports from EIV;
- a checkbox on the electronic Coordinator Access Authorization Form (CAAF) and User Access Authorization Form (UAAF) for certification and re-certification requests prompting External users to certify to the completion of the newly developed *Security Awareness Training Questionnaire* that is now available via HUD’s EIV website for Multifamily Housing Programs; and more.

WARNING: The ***Security Awareness Training Questionnaire*** was posted to Multifamily Housing’s EIV website for download and completion just prior to the close of business on May 13, 2008. All electronic CAAF requests received by HUD’s Multifamily Helpdesk on

May 12 and May 13, 2008, will be **DENIED** because they were transmitted prior to the availability of the **Security Awareness Training Questionnaire**. Such electronic CAAF requests must be resubmitted for approval.

EIV Coordinators who received electronic UAAF requests for certification or re-certification from their Users on May 12 and May 13, 2008, must **DENY** their Users' UAFs and inform them that they must resubmit the UAAF after they have downloaded and completed the **Security Awareness Training Questionnaire**.

Please note the CAAF and UAAF that are currently available in hardcopy on Multifamily Housing's EIV website have been revised to include the certification of the **Security Awareness Training Questionnaire**.

A complete listing of system enhancements has been posted to the EIV website. External business partners and HUD staff may access the newly enhanced system via HUD's Multifamily Housing Programs website at: <http://www.hud.gov/offices/hsg/mfh/rhiip/eiv/eivapps.cfm/>.

EIV Website Update

The EIV System for Multifamily Housing Programs Users website, located at: <http://www.hud.gov/offices/hsg/mfh/rhiip/eiv/eivhome.cfm>, has been updated and redesigned to include a new **EIV Application and Online Access for Multifamily Housing Programs** web page and **EIV Training and Outreach for Multifamily Housing Programs** web page. Pages have been developed to meet the needs of HUD's business partners, making it easier to find related EIV materials in one location.

Further updates were made on May 13, 2008, to include the following materials:

- External Instructions for Applying for EIV Access *Updated*
- Multifamily Housing – Tenant Rental Assistance Certification System (TRACS)/Enterprise Income Verification (EIV) User Access Guide for Multifamily Internal Users (HUD and HUD-OIG Staff) *New*
- Coordinator Access Authorization Form (CAAF) *Updated*
- User Access Authorization Form (UAAF) *Updated*
- EIV Security Awareness Training Questionnaire for Multifamily Housing Programs *New*
- EIV 8.1 Enhancements *New*
- EIV 8.1 System User Manual for Multifamily Housing Programs *New*
- EIV 8.1 System External User Administration Manual for Multifamily Housing Programs *New*

Questions concerning EIV website updates should be directed to HUD's Multifamily Help Desk via email at Mf_EIV@hud.gov. For questions requiring immediate attention, please contact Gail Williamson, Director, Housing Assistance Policy Division, via email at: Gail_Williamson@hud.gov.

Thank you for your interest in HUD's EIV System for Multifamily Housing Programs and for assisting the Department to further reduce income and rent determination errors in HUD's rental assistance programs.

A New Funding Opportunity from HUD

On Friday, April 25, 2008, the Notice of Funding Availability (**NOFA**) for the Demonstration Grant Program for Intergenerational Families in the amount of \$3.96 million was published in the Federal Register volume 73, number 81. Applications are due July 2, 2008. Information can be obtained on the federal grant source website <http://www.grants.gov>. It is crucial for applicants to register early to ensure that they have an opportunity to compete for these funds.

Eligible Applicants:

This opportunity is open to **all** private nonprofit owners of Section 202 Supportive Housing for the Elderly projects.

Satellite Broadcast:

There will be a live satellite broadcast with questions and answers on applying for the Demonstration Grant Program for Intergenerational Families on May 20, 2008 at 3:30pm. You may access the broadcast via satellite at your local Field Office or by using the following satellite coordinates: AM-1 (c-band), Transponder 9, Channel 9, 3880 MHz Horizontal, 103 degrees W. Longitude. The broadcast will also be transmitted through the internet. For more information, please see the grants page of the HUD website www.hud.gov .

Purpose:

The purpose of this demonstration program is to provide affordable rental housing for intergenerational families. Using capital advance and project rental assistance contracts, this demonstration will expand the supply of affordable housing for very low-income grandparents or relatives who are heads of household 62 years of age or older raising a child. The program is managed through the Office of Housing Assistance and Grant Administration in the Office of Housing and will benefit very low income seniors and their families.

Background:

The demonstration program originates from the Legacy Act of 2003, which also required HUD to conduct a study with the Census Bureau on intergenerational housing needs; and to carry out training for federal employees who, through no fault of their own, may be misinterpreting policies that affect the grandparent- and other relative-headed families. To view the webcast of the training, follow this link to HUD webcast archives: <http://hudatwork.hud.gov/services/webcasts/multifamily.cfm>. To read the study, use this link for HUD's Office of Policy Development and Research (PD&R) website: http://www.huduser.org/publications/affhsg/int_genrtnl.html .

For further questions on the demonstration program, please contact **Claire Trivedi (202) 402-6634**.

Multifamily Help Desk for the Enterprise Income Verification (EIV) System

Temporary Interruption in Service

There will be a temporary interruption in the service of the Multifamily Help Desk until approximately May 16, 2008, due to contractual issues. We apologize for this inconvenience and request that all contact with the Multifamily Help Desk be by email to Mf_EIV@hud.gov. Once the contractual issues have been resolved, the Multifamily Help Desk will respond to the emails in the order in which they were received.

IMPORTANT REMINDER

ECONOMIC STIMULUS PAYMENTS (TAX REBATES) EXCLUDED FROM INCOME

The Economic Stimulus payments (tax rebates) received by applicants applying for assisted housing and by tenants participating in HUD's rental assistance programs are excluded from income for the purposes of determining eligibility and rent. The Economic Stimulus Act of 2008 requires this exclusion and the payments are an income exclusion under 24 CFR 5.609(c)(17) of HUD's regulations.

TREATMENT OF MEDICARE PREMIUM

When an applicant's/tenant's Medicare premium is paid by the State or some other entity, the Medicare premium is not included in annual income nor is it included as a medical expense. The Medicare premium is excluded income under 24 CFR 5.609(c)(4) of HUD's regulations. This is a change to guidance issued during the EIV training session in June 2007. Owners/agents who have processed certifications/re-certifications for elderly or disabled tenants that include the Medicare premium as income should process corrections to the certifications/re-certifications.

#95 - EIV System Related Information – April 8, 2008

Important Enterprise Income Verification (EIV) System Related Information

SHARING OF EIV DATA WITH OTHER AGENCIES PROHIBITED

The EIV Social Security (SS), Supplemental Security Income (SSI), new hires (W-4), wage and unemployment compensation information contained in the EIV system may only be used for limited official purposes – by owners/agents (O/As) for verifying the employment and income at the time of recertification for tenants participating in one of HUD's rental assistance programs listed below, by Contract Administrators (CAs) for monitoring and oversight of the tenant recertification process and by the Office of the Inspector General (OIG) for investigative purposes. These programs include:

- Project-based Section 8
 - New Construction
 - State Agency Financed
 - Substantial Rehabilitation
 - Section 202/8
 - Rural Housing Services Section 515/8
 - Loan Management Set-Aside (LMSA)
 - Property Disposition Set-Aside (PDSA)
- Rent Supplement
- Rental Assistance Payment (RAP)
- Section 202/162 Project Assistance Contract (PAC)
- Section 202 Project Rental Assistance Contract (PRAC)
- Section 811 PRAC
- Section 236
- Section 221(d)(3) Below Market Interest Rate (BMIR)

Official use does **not** include O/As using the EIV data for certifying tenants under the Low Income Housing Tax Credit (LIHTC) or Rural Housing Services (RHS) Section 515 programs since neither the Internal Revenue Service (IRS) nor RHS are a party to the computer matching agreements the Department has with the Department of Health and Human Services (HHS) and with the Social Security Administration (SSA). The fact that there is financing through other federal agencies involved in a particular property under one of the authorized HUD programs does not permit that federal agency to **use or view** information from the EIV system for certifying tenants for their programs or for monitoring purposes.

TENANT CONSENT FORM HUD-9887 NECESSARY BEFORE EIV DATA MAY BE ACCESSED

Before accessing the employment or income data contained in the EIV system for a tenant, the O/A must make sure there is a current form HUD-9887, *Notice and Consent for the Release of*

Information, signed and dated by the tenant(s), on file. This form must be signed and dated by the head of household, spouse, co-head, regardless of age, and by each family member who is at least 18 years of age, at the time of move-in and at each annual recertification.

Paragraph 7-10 of Handbook 4350.3 REV-1, *Occupancy Requirements of Subsidized Multifamily Housing Programs*, states that tenants are not required to report when a family member turns 18 years of age between annual recertifications. However, before accessing any employment or income information on an individual who turns 18 between annual recertifications, the O/As must make sure they have the 18 year old sign and date the HUD-9887 consent form as soon as possible after the person turns 18 if employment or income data contained in the EIV system will be accessed for this person.

TREATMENT OF MEDICARE PREMIUMS IN ANNUAL INCOME

When the Medicare premium is paid by the tenant, the **gross amount** of social security that **includes** the Medicare premium amount **is included** in annual income. This will be reflected in EIV when the net benefit amount being paid to the tenant is less than the gross benefit amount **and** the Medicare premium amount is listed under the Supplemental Medical Insurance. The amount of the Medicare premium is included as a medical expense when calculating the medical expense deduction. NOTE: The O/A must make sure that the Medicare premium amount is listed under the Supplemental Medical Insurance since the difference between the gross and net benefit may include the Medicare premium and/or additional deductions, such as garnishments, Medicare Part D prescription drug plan premiums, which are not listed on the benefit report.

When the Medicare premium is paid by the state or another entity, the **gross amount** of social security that **does not include** the Medicare premium amount **is included** in annual income. In this instance, this will be reflected in EIV when the gross benefit and the net benefit for the tenant are the same. The benefit statement will include the Medicare premium amount, a "Y" in the Buy-In column and a date in the Buy-In Start columns under the Supplemental Medical Insurance. The amount of the Medicare premium **is not included** in annual income or as a medical expense.

USING EIV DATA CONFERENCE CALL POWERPOINT PRESENTATION POSTED

On March 20, 2008, Headquarters staff held a conference call with the HUD Rental Housing Integrity Improvement Project (RHIP) Help Desk Representatives, Traditional Contract Administrators (TCAs) and the Performance Based Contract Administrators (PBCAs) on using the data and reports contained in the EIV system. The power point slides used in this presentation are posted as a PDF file on the RHIP Web site at:

<http://www.hud.gov/offices/hsg/mfh//rhiip/mfhrhiip.cfm>. O/As are encouraged to download and view this information as it will answer many questions regarding EIV data updates and using, safeguarding and retaining the employment and income information and reports contained in the EIV system.

SIGN-UP FOR ACCESS TO THE EIV SYSTEM

Owners/management agents who have not signed up for access to the EIV system are encouraged to do so. Instructions for getting access to the system are posted on the Multifamily EIV website located at:

<http://www.hud.gov/offices/hsg/mfh//rhiip/eiv/eivhome.cfm>

HUD WANTS TO HEAR FROM YOU

HUD's Office of Multifamily Housing leadership wants to hear from you about your experiences, both positive and negative, in gaining access to the EIV system and in using the various Multifamily applications and reports contained in the EIV system. Please take the time to submit your comments, concerns and recommendations to the following mailbox to help HUD make the EIV system a more useful tool that is responsive to your needs:

MF_EIV_Comments@hud.gov

#94 – Operating Cost Adjustment Factor (OCAF) HUD-9625 Worksheet Updated – March 20, 2008

Operating Cost Adjustment Factor (OCAF) Rent Adjustment Worksheet (HUD-9625) - Updated

There was a minor technical glitch in the Excel version of the OCAF Rent Adjustment Worksheet (form HUD-9625) that was posted on the website last week. The glitch has been fixed and the repaired form has been posted to the website. The updated Worksheet is dated (10/2007) and is posted at the following website address:

<http://www.hud.gov/offices/adm/hudclips/forms/hud9a.cfm#group4>

IMPORTANT UPDATE FOR ENTERPRISE INCOME VERIFICATION (EIV) USERS

The (NDNH) new hires (W-4), wage and unemployment compensation benefit information and the social security benefit information is now available in EIV for Section 236 and Section 221(d)(3) BMIR tenants. Owners and managements agents should now be able to access this data for tenants currently participating in these programs.

#92 – No Posting (skipped #)

Operating Cost Adjustment Factor (OCAF) Rent Adjustment Worksheet

(HUD-9625) - Updated

The OCAF Rent Adjustment Worksheet (form HUD-9625) has been updated.

1. The revised Worksheet comes in two forms; a pdf and an Excel spreadsheet.
2. The revised Worksheet contains a line for entering the OCAF Adjustment (Line N).
3. New instructions are also included.

NOTE: For HUD-insured loans, add the mortgage insurance premium (MIP) to the principal and interest to obtain the total debt service amount for line "K" Total Annual Project Debt Service.

The updated Worksheet is dated (10/2007) and is posted at the following website address:
<http://www.hud.gov/offices/adm/hudclips/forms/hud9a.cfm#group4>

#90 – EIV News (SSA Information for Section 236 and 221(d)(3) BMIR Tenants) - March 11, 2008

IMPORTANT NEWS FOR ENTERPRISE INCOME VERIFICATION (EIV) USERS

The social security information is now in EIV for Section 236 and Section 221(d)(3) BMIR tenants. Owners and managements agents should now be able to access the social security, supplemental security income and dual entitlement benefit information for tenants currently participating in these programs.

The National Directory of New Hires (NDNH) new hires (W-4), wage and unemployment compensation benefit information should be available in EIV for Section 236 and Section 221(d)(3)BMIR tenants the week of March 17. A Listserv message will be sent out when the NDNH data is available.

Section 8 Renewal Policy Guidebook - Updated

The Section 8 Renewal Policy Guidebook has been updated to:

1. Incorporate two previously approved page changes of 5/5/06 and 12/12/06;
2. Include minor editorial changes such as using Office of Affordable Housing Preservation (OAHF) instead of Office of Multifamily Housing Assistance Restructuring (OMHAR) and provide updated web addresses, and;
3. Remove some forms, worksheets and the renewal contracts, which are obsolete. The forms and the accompanying instructions are now found on HUDCLIPS. The worksheets and latest contracts are on the web at <http://www.hud.gov/offices/hsg/mfh/mfhsec8.cfm>.

The updated Guidebook is dated 1/15/08 (revised as of 12/12/06) and is posted at the following website address: <http://www.hud.gov/offices/hsg/mfh/mfhsec8.cfm>

#88 –Economic Stimulus Tax Rebates 2008; HUD Releases 2008 Income Limits; and Growing Number of Listserv Subscribers – February 20, 2008

Tax Rebates 2008

The Tax Rebates received by tenants from President Bush's economic stimulus program are not to be counted as income. The HUD Handbook 4350.3 Rev- 1 defines income inclusions and exclusions. Specific reference that relates to the tax rebate can be found in Chapter 5-6.F.3 and Exhibit 5-1 Income Exclusions (9): "Temporary, nonrecurring, or sporadic income (including gifts) is not counted."

HUD Releases 2008 Income Limits

The 2008 Income Limits have been posted on the HUDUser Web Site at <http://www.huduser.org/datasets/il/il08/index.html>
These income limits are effective as of 2/13/2008.

5,000 Subscribers and Growing

There are now 5,000 subscribers to this Listserv – please continue to encourage coworkers and colleagues to sign up as we would like to continue increasing the number of subscribers. Individuals may subscribe to the Listserv at the following web address:
<http://www.hud.gov/subscribe/maillinglist.cfm>.

#87 – Disability.gov and Frequently Asked Questions – February 11, 2008

HUD & DisabilityInfo.gov

RHIIP Listserv posting #86 on February 8th, contained information regarding HUD & DisabilityInfo.gov. As an additional resource, please see the attached file for a listing of Frequently Asked Questions about the DisabilityInfo.gov Web site.

DisabilityInfo.gov Frequently Asked Questions

DisabilityInfo.gov is a comprehensive online resource designed to provide people with disabilities access to the information they need quickly and easily. The site contains links to disability-related programs and services from many different government agencies. DisabilityInfo.gov's subject areas include benefits, civil rights, community life, education, employment, health, housing, technology and transportation.

What is DisabilityInfo.gov?

DisabilityInfo.gov (www.disabilityinfo.gov) is an award-winning federal government Web site that connects users to information and resources on a wide range of disability-related topics. It is a one-stop Web site where people with disabilities can easily find the resources they need to fully participate in the workforce and in their communities.

Who benefits from DisabilityInfo.gov?

DisabilityInfo.gov offers valuable information to the nearly 50 million people with disabilities in the United States. It is also a useful resource for parents of children with disabilities, employers, workforce and human resource professionals, veterans and active military personnel, faith-based and community organizations and many others.

What information is available on DisabilityInfo.gov?

DisabilityInfo.gov includes news and information from federal government agencies, state governments, universities, service providers and non-profit organizations. Information on DisabilityInfo.gov is organized into nine subject areas including benefits, civil rights, community life, education, employment, health, housing, technology and transportation.

What federal government agencies contribute information to DisabilityInfo.gov?

Federal agencies contributing information to DisabilityInfo.gov include the U.S. departments of Agriculture, Commerce, Defense, Education, Health & Human Services, Homeland Security, Housing & Urban Development, Interior, Justice, Labor, Transportation, Treasury and Veterans Affairs; as well as the Access Board, the Corporation for National and Community Service, Equal Employment Opportunity Commission, the Federal Communications Commission, the General Services Administration, the National Council on Disability, the Office of Personnel Management, the Small Business Administration and the Social Security Administration.

How are these federal government agencies working together on DisabilityInfo.gov?

DisabilityInfo.gov is managed by the U.S. Department of Labor's Office of Disability Employment Policy (ODEP), and is a collaborative effort among the 22 government agencies listed above. By ensuring that the most up-to-date information about their disability-related programs and services is included on the Web site, these agencies have partnered to make DisabilityInfo.gov the leading federal resource for disability-related information.

Can I find information about services and resources in my state on DisabilityInfo.gov?

DisabilityInfo.gov's state and local resources map enables users to find disability-related information in their states and communities. To use this map, select one of the nine subject tabs at the top of any DisabilityInfo.gov page, and then click the map on the right sidebar to find information on that subject in your state.

Visit DisabilityInfo.gov's Press Room for more information including news briefs and articles that you can print in your own publications. DisabilityInfo.gov also offers an e-mail subscription service to help you stay informed about disability-related subjects of interest to you.

U.S. Department of Labor
Office of Disability Employment Policy
200 Constitution Avenue, NW
Washington, DC 20210
1-866-ODEP-DOL (633-7365)
TTY: 1-877-889-5627

HUD & DisabilityInfo.gov

The Department of Housing & Urban Development (HUD) is one of 22 federal agencies working together to support a vital online resource called **DisabilityInfo.gov**. DisabilityInfo.gov (www.disabilityinfo.gov) is a one-stop federal Web site designed to offer people with disabilities access to the information and resources they need to fully participate in the workforce and in their communities. The site offers a broad range of valuable information, not only for people with disabilities, but also for housing agencies, PHAs, fair housing advocates, and community and faith-based service providers.

DisabilityInfo.gov is organized into subject areas that include benefits, civil rights, community life, education, employment, health, housing, technology and transportation. By selecting a category from the tabs at the top of the home page, visitors to the Web site are directed to practical information on housing assistance, the Fair Housing Act, accessibility and universal design, and information on HUD-subsidized properties that serve the elderly and persons with disabilities. DisabilityInfo.gov also now has a State & Local Resource Map to make it easier to find help in your community.

DisabilityInfo.gov offers a free subscription service where you can sign up to receive *Disability Info Connection*, the site's quarterly newsletter, as well as other e-mail alerts covering information tailored to your individual interests. Visit this link to subscribe and begin receiving updates on new information that has been added to the site.



DisabilityInfo.gov

The Federal Government's Online Resource for People with Disabilities

Frequently Asked Questions

DisabilityInfo.gov

DisabilityInfo.gov is a comprehensive online resource designed to provide people with disabilities access to the information they need quickly and easily. The site contains links to disability-related programs and services from numerous government agencies. DisabilityInfo.gov's subject areas include benefits, civil rights, community life, education, employment, health, housing, technology and transportation.



What is DisabilityInfo.gov?

DisabilityInfo.gov (www.disabilityinfo.gov) is an award-winning federal government Web site that connects users to information and resources on a wide range of disability-related topics. It is a one-stop Web site where people with disabilities can easily find the resources they need to fully participate in the workforce and in their communities.



Who benefits from DisabilityInfo.gov?

DisabilityInfo.gov offers valuable information to the nearly 50 million people with disabilities in the United States. It is also a useful resource for parents of children with disabilities, employers, workforce and human resource professionals, veterans and active military personnel, faith-based and community organizations and many others.



What information is available on DisabilityInfo.gov?

DisabilityInfo.gov includes news and information from federal government agencies, state governments, universities, service providers and non-profit organizations. Information on DisabilityInfo.gov is organized into nine subject areas including benefits, civil rights, community life, education, employment, health, housing, technology and transportation.



What federal government agencies contribute information to DisabilityInfo.gov?

Federal agencies contributing information to DisabilityInfo.gov include the U.S. departments of Agriculture, Commerce, Defense, Education, Health & Human Services, Homeland Security, Housing & Urban Development, Interior, Justice, Labor, Transportation, Treasury and Veterans Affairs; as well as the Access Board, the Corporation for National and Community Service, Equal Employment Opportunity Commission, the Federal Communications Commission, the General Services Administration, the National Council on Disability, the Office of Personnel Management, the Small Business Administration and the Social Security Administration.



How are these federal government agencies working together on DisabilityInfo.gov?

DisabilityInfo.gov is managed by the U.S. Department of Labor's Office of Disability Employment Policy (ODEP), and is a collaborative effort among the 22 federal government agencies listed above. By ensuring that the most up-to-date information about their disability-related programs and services is included on the Web site, these agencies have partnered to make DisabilityInfo.gov the leading federal resource for disability-related information.



Can I find information about programs and resources in my state on DisabilityInfo.gov?

DisabilityInfo.gov's state and local resources map makes it easy for you to find disability-related information in your state. To use this map, select one of the nine subject tabs at the top of any DisabilityInfo.gov page, and then click the map on the right sidebar to find information on that subject in your state.

U.S. Department of Labor
Office of Disability Employment Policy

200 Constitution Avenue, NW
Washington, DC 20210
1-866-ODEP-DOL (633-7365)
TTY: 1-877-889-5627

Visit DisabilityInfo.gov's Press Room for more information including news briefs and articles that you can print in your own publications. DisabilityInfo.gov also offers an e-mail subscription service to help you stay informed about disability-related subjects of interest to you.

www.disabilityinfo.gov

#85 – EIV Mailbox; and RHIP Tip (Federally Mandated Exclusion from Income) – January 30, 2008

ATTENTION MULTIFAMILY ENTERPRISE INCOME VERIFICATION (EIV) SYSTEM USERS

HUD Wants to Hear from You!

HUD's Office of Multifamily Housing leadership wants to hear from you about your experiences, both positive and negative, in gaining access to the EIV system and in using the various Multifamily applications and reports contained in the EIV system. Please take the time to submit your comments, concerns and recommendations to the following mailbox to help HUD make the EIV system a more useful tool that is responsive to your needs:

MF_EIV_Comments@hud.gov

Owners/management agents who have not signed up for access to the EIV system are encouraged to do so. Instructions for getting access to the system are posted on the Multifamily EIV website located at:

<http://www.hud.gov/offices/hsg/mfh//rhiip/eiv/eivhome.cfm>

RHIP Tip: FEDERALLY MANDATED EXCLUSION FROM INCOME

Payments to Volunteers under the Domestic Volunteer Services Act of 1973 (42 U.S.C. 5044(g), 5058) (employment through AmeriCorps, Volunteers in Service to America (VISTA), Retired Senior Volunteer Program, Foster Grandparents Program, youthful offender incarceration alternatives, senior companions).

See Handbook 4350.3 REV-1, *Occupancy Requirements of Multifamily Housing Programs*, Exhibit 5-1: Income Inclusions and Exclusions, for more information.

ATTENTION ENTERPRISE INCOME VERIFICATION (EIV) USERS

The W-4 (new hires), unemployment benefit and wage information is now available in EIV and can be accessed by using the head-of-household search feature. Starting next week reports such as the discrepancy report and the search by reexamination month reports will also be available for your use.

#83 – Handbook 4350.3, Rev-1 Correct Version on HUDCLIPS – January 18, 2008

CORRECT VERSION OF HANDBOOK 4350.3 REV-1 POSTED ON HUDCLIPS

The correct version of Handbook 4350.3 REV-1, *Occupancy Requirements of Subsidized Multifamily Housing Programs*, Change 2 is now posted on HUDCLIPS at:

<http://www.hud.gov/offices/adm/hudclips/handbooks/hsg/4350.3/index.cfm>

**#82 – SSA Benefit Data in EIV; and Handbook 4350.3, Chg. 2 Posting Problems –
January 17, 2008**

SOCIAL SECURITY BENEFIT DATA IN ENTERPRISE INCOME VERIFICATION (EIV)

As of January 14, 2008, the Social Security Administration (SSA) benefit data in EIV includes the latest cost of living adjustment.

**HUD HANDBOOK 4350.3 REV-1, Change 2, POSTED ON HUDCLIPS CONTINUES TO HAVE
PROBLEMS**

The Handbook 4350.3 REV-1, *Occupancy Requirements of Subsidized Multifamily Housing Programs*, was re-posted to HUDCLIPS on January 14, 2008. However, there continues to be a problem with the posting of Chapters 6 and 7 which should be corrected soon. A new notice will be posted once all of the posting problems have been corrected.

ENTERPRISE INCOME VERIFICATION (EIV) NEWS

1. NATIONAL DIRECTORY OF NEW HIRES (NDNH) DATA AVAILABLE IN EIV THIS WEEK

Goods News! - Owners and management agents (O/As) will have access to the NDNH W-4 (new hires), wage and unemployment benefit data through the EIV system beginning **January 16 or 17, 2008**. This data may be used at the time of recertification to assist O/As in determining a tenant's income. O/As who have not applied for access to the EIV system should do so. Instructions for obtaining access are posted on the Multifamily EIV web site at: <http://www.hud.gov/offices/hsg/mfh//rhiip/eiv/eivhome.cfm#top>.

2. ATTENTION EIV USERS

EIV Users (not EIV Coordinators) must be re-certified by January 30, 2008 in order to prevent an interruption in access to EIV. EIV Users must submit the re-certification request electronically to their EIV Coordinator by using the User Access Request option in EIV. The EIV Coordinator will re-certify the EIV User for each project/contract assigned to them. For more instructions on submitting the re-certification request, see Chapter 6, Paragraph 6.3 of the EIV Systems User Manual for Multifamily Program Users posted on the EIV website at:

<http://www.hud.gov/offices/hsg/mfh//rhiip/eiv/eivhome.cfm>

OTHER ITEMS OF INTEREST:

1. HUDCLIPS HAS MOVED TO THE WEB

One of the most popular resources for linking directly to a handbook or form is HUDCLIPS. Providing clients with fast, easy and FREE access to HUD's official repository of policies, procedures, announcements, and other materials, HUDCLIPS is now on the Web and is easier to use. Clients can now link directly to the handbook or form they need without having to search each time they need to use it. Be sure to create a new bookmark to link to this important and useful website. The new HUDCLIPS is located at: <http://www.hud.gov/offices/adm/hudclips/index.cfm>

2. WRONG VERSION OF HANDBOOK 4350.3 REV-1 POSTED ON THE NEW HUDCLIPS

The wrong version of handbook 4350.3 REV-1, *Occupancy Requirements of Subsidized Multifamily Housing Programs*, was posted to the new HUDCLIPS when it came online. We are working to get the correct version released in June 2007 posted. A Listserv message will be posted when the correct version of the handbook has been posted.

RHIIP TIP

Transportation expenses for going to and from medical treatment are considered an eligible medical expense. Actual cost (e.g. bus fare) or, if driving in a car, a mileage rate based on Internal Revenue Service (IRS) rules or other accepted standards may be included.

The IRS mileage rate for medical purposes beginning January 1, 2008, is 19 cents per mile.

See Paragraph 5-10. D and Exhibit 5-3 of Handbook 4350.3 REV-1, *Occupancy Requirements of Subsidized Multifamily Housing Programs*, for more information on the Medical Expense Deduction.

#80 – Final Notification – Shutdown of SSA Data Matching - December 26, 2007

!!!! FINAL NOTIFICATION !!!!

The Social Security Administration (SSA) Data Matching process through the Tenant Rental Assistance Certification System (TRACS) will be discontinued in less than 4 business days. The process will be shut down December 31, 2007. After that date, income verification will ONLY be available through the Enterprise Income Verification (EIV) system. If you have not done so already, you must obtain access to EIV immediately and become familiar with the system's functionality. Instructions for obtaining access to EIV are posted on the Multifamily EIV web site at: <http://www.hud.gov/offices/hsg/mfh/rhiip/eiv/eivhome.cfm#top>

#79 – Protocol for Occupancy Issues, EIV Sign-up Access; and RHIP Tip (Affirmative Fair Housing Marketing Plan) - December 10, 2007

PROTOCOL FOR SUBMITTING QUESTIONS ON OCCUPANCY RELATED ISSUES

In an effort to provide quick and complete responses to occupancy related questions or questions relating to requirements addressed in HUD Handbook 4350.3 REV-1, *Occupancy Requirements of Subsidized Multifamily Programs*, the following communication protocol should be followed:

1. Owners, management agents, on-site staff, etc. whose contract(s) is being administered by a Performance Based Contract Administrator (PBCA) or Traditional Contract Administrator (TCA) should direct their question(s) to the PBCA or TCA. PBCAs and TCAs who need additional guidance and/or clarification in order to respond to the owner etc all should contact the appropriate HUD field office and the designated point of contact
2. Owners, management agents, on-site staff, etc. whose project(s)/contract(s) is being administered by a HUD Program Center or Hub, should direct their questions to the appropriate HUD field office. HUD field office staff will follow their offices established protocol for responding to occupancy related questions.
3. Other HUD business partners, such as trainers of the occupancy requirements addressed in Handbook 4350.3 REV-1, should contact the HUD Program Center or Hub in their locality for assistance.
4. Only after the above established protocol is followed and a response to the question(s) cannot be provided by HUD field office staff should the question be sent via email to diane.r.hooten@hud.gov at HUD headquarters for response or resolution.
5. Upon receipt of the response from HUD headquarters, HUD field office staff will provide the response or resolution to the entity that submitted the question.

HAVE YOU SIGNED UP FOR ACCESS TO ENTERPRISE INCOME VERIFICATION (EIV)?

HUD encourages owners/management agents (O/As) who have not applied for access to the EIV system, to do so. EIV is a tool that provides O/As access to income information for their tenants for use at recertification. EIV currently contains social security benefit information. However, starting in early January 2008, wage, W-4 (new hires) and unemployment benefit information will also be available. Instructions for obtaining access to EIV are posted on the Multifamily EIV web site at: <http://www.hud.gov/offices/hsg/mfh/rhip/eiv/eivhome.cfm#top>.

RHIP Tip:

Owners must review, and if necessary revise, their Affirmative Fair Housing Marketing Plan every five years or when the local Community Development jurisdiction's Consolidated Plan is updated.

See Paragraph 4-12.F of HUD Handbook 4350.3 REV-1, *Occupancy Requirements of Subsidized Multifamily Housing Programs*, for further guidance on updating the marketing plan.

Enterprise Income Verification (EIV) NEWS FLASH

The Computer Matching Agreement (CMA) has been executed between the Department of Housing and Urban Development (HUD) and the Department of Health and Human Services (HHS) allowing HUD's multifamily business partners (owners, management agents, contract administrators) to have access to HHS' National Directory of New Hires (NDNH) data in HUD's EIV system. Notification of HUD's intent to conduct the computer matching program has also been submitted to Congress and the Office of Management and Budget.

By early January 2008, owners and management agents (O/As) of Multifamily Housing properties will be able to access in EIV the new hires (W-4), wage and unemployment benefit information from NDNH for tenants living in their assigned projects/contracts. O/As will be able to use this data, as well as the social security benefit information contained in the EIV system, for verifying and determining the accuracy of tenant and employer reported income for existing tenants at recertification. **Contract administrators will use information in EIV for monitoring purposes.** A Listserv message will be sent out and an update will be posted on the EIV website of the date when the NDNH information will be available in EIV.

HUD encourages O/As who have not applied for access to the EIV system, to do so. Instructions for obtaining access are posted on the Multifamily EIV web site at:
<http://www.hud.gov/offices/hsg/mfh//rhiip/eiv/eivhome.cfm#top>.

ADDITIONAL TOOLS AVAILABLE FOR ACCESSING AND USING EIV:

1. EIV System User Manual for Multifamily Housing Programs posted at:
<http://www.hud.gov/offices/hsg/mfh//rhiip/eiv/eivhome.cfm#top>
2. Archive of EIV Training webcast presented on June 27 and June 28, 2007 is posted at:
<http://www.hud.gov/webcasts/archives/multifamily.cfm>

#77 – EIV System Coordinator Updates; and Items of Interest (Proposed Rule Pet Ownership, Form HUD-93104, Monthly Report of Excess Income, 2008 OCAFs, & Revised Index for Handbook 4350.3 REV-1) - October 25, 2007

Attention Enterprise Income Verification (EIV) System Coordinators

The fax machine for the Multifamily Help Desk is back in service. EIV Coordinators may now submit their Coordinator Access Authorization Form (CAAF) requesting re-certification of their contract(s) and/or property(ies) by either faxing the completed CAAF to the Multifamily Help Desk at (202) 401-7984 or by email at Mf_Eiv@hud.gov.

Items of Interest posted at www.hudclips.org

1. A Proposed Rule revising HUD's regulations that apply to pet ownership in HUD-assisted housing for the elderly and persons with disabilities by conforming the exceptions for animals that assist persons with disabilities to those that apply to HUD's public housing programs was published in the October 15, 2007 Federal Register. .

2. Form HUD-93104, Monthly Report of Excess Income, has been revised and posted under Forms.

HUD Multifamily Excess Rental Income Payments
P.O. Box 105423
Atlanta, GA 30348-5423

3. The Operating Cost Adjustment Factors (OCAF) for 2008 were published in the October 25, 2007 Federal Register. These factors are used for adjusting or establishing Section 8 rents under the Multifamily Assisted Housing Reform and Affordability Act of 1997 (MAHRA), as amended, and under the Low-Income Housing Preservation and Resident Homeownership Act of 1990 (LIHPRHA) projects assisted with Section 8 Housing Assistance Payments. The factors are effective February 11, 2008.

4. The revised Index for HUD Handbook 4350.3 REV-1, *Occupancy Requirements of Subsidized Multifamily Housing Programs* is now posted on HUDclips.

#76 – EIV Coordinator Updates - October 18, 2007

Attention Enterprise Income Verification (EIV) System Coordinators

This notice supplements RHIP Listserv message #73 that was posted on October 11, 2007.

As a result of the October 11, 2007 RHIP Listserv message, the Multifamily Help Desk is receiving Coordinator Access Authorization Forms (CAAFs) requesting re-certification from EIV Coordinators who are **not due for re-certification** between October 31, 2007 and December 31, 2007. **If you are an EIV Coordinator and are not due for re-certification between these dates, please do not submit your CAAF re-certification request to the Multifamily Help Desk at this time.**

o If you are unsure of when to submit your recertification CAAF, you may contact the Multifamily Help Desk for that information. The telephone number is: 1-800-767-7588

If at all possible, EIV Coordinators should submit their recertification CAAF to the Multifamily Help Desk by email at Mf_Eiv@hud.gov instead of by fax because at the present time the fax machine is out of service. It is hoped that the fax machine will be back on line soon but, in the meantime, submitting your CAAF recertification request by email will help to ensure that it is processed more timely.

When submitting the recertification CAAF to the Multifamily Help Desk:

- o Do **not** include a cover sheet;
- o Do **not** include the instructions; and
- o Only submit one recertification CAAF for all properties/contracts that require recertification between October 31, 2007 and December 31, 2007. If there is not enough room to list all such properties/contracts, a separate sheet may be attached.

Thank you for your cooperation in following the above instructions.

#75 - Records Retention for Resident Criminal Records; and EIV Income Reports – October 17, 2007

Clarification on Retention of Resident Criminal Records

HUD Handbook 4350.3 Chg-2, 8-14 C 13 states "All criminal records received are to be maintained confidentially, not misused or improperly disseminated; and destroyed upon completion of the originally intended use. When destroying records of criminal background, a notation should be made in the tenant file that includes the date the records are destroyed and a statement that the records were destroyed for purposes of confidentiality."

To clarify, criminal background checks not obtained by a Public Housing Authority (PHA) on behalf of an owner should be retained for the term of tenancy plus three years after tenancy is terminated. Criminal background checks obtained by the PHA on behalf of an owner must be destroyed by the PHA in accordance with the regulations at 24 CFR 5.903(g).

Enterprise Income Verification (EIV) Income Reports

As directed in the June 2007 EIV HUD web training, the EIV income report must be destroyed by burning or shredding the document as soon as it has served its purpose or as prescribed by HUD's policies and procedures. HUD policies and procedures require that the EIV income reports be retained in the tenant file for the term of tenancy plus three years after tenancy is terminated.

#74 – EIV Update for Coordinators (Correction to Posting #73) – October 11, 2007

Attention Enterprise Income Verification (EIV) System Coordinators

Welcome to the MULTIFAMILY HOUSING RENTAL HOUSING INTEGRITY IMPROVEMENT PROJECT (RHIIP) LISTSERV that brings you up-to-date RHIIP related publications, news, information and occupancy tips in an effort to help reduce errors in rent determinations and subsidy calculations.

Listserv posting #73, posted on October 11th, contained specific information for Enterprise Income Verification (EIV) system coordinators.

CORRECTION: This posting is to provide the link for the updated Coordinator Access Authorization Form (CAAF) which is available on Multifamily Housing's Enterprise Income Verification (EIV) System webpage at

<http://www.hud.gov/offices/hsg/mfh/rhiip/eiv/eivhome.cfm> under Helpful Tools.

#73 – EIV Update for Coordinators – October 11, 2007

Attention Enterprise Income Verification (EIV) System Coordinators

- The first annual re-certification of an EIV Coordinator's contract(s) and/or property(ies) within EIV is due by **October 31, 2007**.

EIV Coordinators must complete an updated Coordinator Access Authorization Form (CAAF) requesting re-certification of their contract(s) and/or property(ies) and submit it to HUD's Multifamily Helpdesk according to the following schedule which is based upon when they submitted their initial CAAF for access to EIV.

- If the initial CAAF was sent between **July 21, 2006** and **November 30, 2006**, the re-certification CAAF request must be sent **before October 31, 2007** to avoid a possible interruption in service after this date.
- If the initial CAAF was sent between **December 1, 2006** and **December 31, 2006**, the re-certification CAAF request must be sent between **November 16, 2007** and **December 14, 2007** to avoid a possible interruption in service after December 31, 2007.

The updated CAAF is available on Multifamily Housing's Enterprise Income Verification (EIV) System webpage at <http://www.hud.gov/offices/hsg/mfh/rhiip/eiv/> under Helpful Tools.

The completed CAAF requesting recertification must be submitted to HUD's Multifamily Helpdesk according to the above schedule via fax at 202/401-7984 or by email at: Mf_Eiv@hud.gov.

As the initial deadline of October 31, 2007 is fast approaching, EIV Coordinators who, based upon the above schedule, must submit their re-certification CAAF request by October 31, 2007 should do so as soon as possible because if it is submitted shortly before or after **October 31, 2007**, they are likely to experience a temporary interruption in service. HUD's Multifamily Helpdesk will process these and all requests as quickly as possible.

Thank you for your patience and cooperation in adhering to the established schedule.

- EIV Coordinators who submitted their initial CAAF requests for EIV access to HUD's Multifamily Helpdesk on or after **January 01, 2007** need not submit their CAAF requests for re-certification of their contract(s) and/or property(ies) to HUD's Multifamily Helpdesk. The capability for EIV Coordinators to see when their contract(s) and/or property(ies) is due for annual re-certification within EIV will come with the EIV 8.0 release scheduled for December 07, 2007. The ability to complete and submit on-line CAAF requests for re-certification of a contract(s) and/or property(ies) to HUD's Multifamily Helpdesk for approval, through EIV, will also come with the EIV 8.0 release in December. The EIV User Manual and the External User Administration Manual will be updated to include instructions on using the enhanced EIV system.
- For continued updates, please see HUD's Enterprise Income Verification (EIV) System Updates for Multifamily Housing Program Users web page at: <http://www.hud.gov/offices/hsg/mfh/rhiip/eiv/sysupdates.cfm>. Thank you for your interest in HUD's EIV System and for assisting the Department in further reducing income and rent determination errors in HUD's rental assistance programs through use of the EIV system.

#72 – Updated Information for Obtaining Access to the Systematic Alien Verification for Entitlements (SAVE); and RHIP Tip (Terminating Tenant’s Assistance) – September 11, 2007

1. UPDATED INFORMATION FOR OBTAINING ACCESS TO THE DEPARTMENT OF HOMELAND SECURITY’S SAVE SYSTEM

For those of you who received this LISTSERV message regarding the Systematic Alien Verification for Entitlements (SAVE) System earlier this summer...

ATTENTION PLEASE

If you have already submitted the required information below to *Voneka Bennett* as instructed by the previous Listserv message posted on August 2, 2007, and still do not have access to the SAVE system, please resubmit the required information as instructed below to **Kevin Garner**. We apologize for any inconvenience this may have caused you.

HUD’s rental assistance is restricted to United States citizens and eligible non-citizens. Owners/management agents (O/As) are responsible for ensuring that the documents provided by non-citizen applicants are valid by verifying the information disclosed in these documents with the Department of Homeland Security (DHS).

The SAVE Program Branch of DHS provides O/As access to an automated verification system consisting of immigration status and employment eligibility verification information. In order to retrieve this information, owners must obtain an access code and user ID from DHS by submitting his or her request via email to Kevin_X._Garner@hud.gov or via telephone at (202) 402-2057. The O/A’s request must include the following information:

1. Name of the apartment complex
2. Contract number for the property
3. Physical address for the property (*no P.O. Box addresses*)
4. Phone number for the property
5. Fax number for the property
6. Name of the contact person
7. Email address for the contact person

HUD will forward this information to DHS requesting that the owner be granted access to the verification system. DHS will process the owner’s request within approximately 3 business days and notify the owner directly via email that he or she has been given access to the [SAVE](#) system.

2. RHIP Tip:

When terminating a tenant’s assistance, the owner must provide a written notice to the tenant that should include:

- The specific date the assistance will terminate;
- The reason(s) for terminating the assistance;
- The amount of rent the tenant will be required to pay;
- Notification that if the tenant fails to pay the increased rent, the owner may terminate tenancy and seek to enforce the termination in court; and

- The tenant has a right to request, within 10 calendar days from the date of the notice, a meeting with the owner to discuss the proposed termination of assistance.

See Paragraph 8-6 of HUD Handbook 4350.3 REV-1, *Occupancy Requirements of Subsidized Multifamily Housing Programs*, for further procedures on terminating or reinstating assistance.

#71– Revised Section 8 HAP Contracts; HUD Handbook 4350.3 REV-1 Summary of Questions; and RHIP Tip (Existing Tenant Search) - August 31, 2007

1. Revised Section 8 Housing Assistance Payments (HAP) Contracts:

The Section 8 HAP Contracts used for renewals under the Multifamily Assisted Housing Reform and Affordability Act of 1997 (MAHRA) have been revised and are posted on the Office of Housing's Section 8 Contract website at:

<http://www.hud.gov/offices/hsg/mfh/mfhsec8.cfm>

2. HUD Handbook 4350.3 REV-1 Summary of Questions:

The Final Multifamily Mailbox: 4350.3 REV-1 Summary of Questions has been reposted to the Multifamily Housing's RHIP website at <http://www.hud.gov/offices/hsg/mfh/rhiip/mfhrhiip.cfm>. The Summary of Questions was removed temporarily while the handbook references, questions and answers were revised to be in compliance with Change 2 to the Handbook.

A listing of Frequently Asked Questions pertaining to the revisions contained in Change 2 to the Handbook is being prepared and will be released at a later date.

3. RHIP Tip:

The **Existing Tenant Search** feature in the Enterprise Income Verification (EIV) system allows owners and management agents to search if an applicant or a member of the applicant's household is being assisted at another location under an Office of Housing and/or Public and Indian Housing (PIH) rental assistance program.

HUD strongly encourages use of the **Existing Tenant Search** option before admitting new applicants into subsidized properties. If the search reveals the applicant or a member of the applicant's family is being assisted at another location, the owner or management agent (O/A) should confirm with the applicant, the applicant's program participation status at the other location before admission of the applicant to his/her property. The O/A may also need to contact management at the other location where the applicant is being assisted to determine the applicant's move-out date or termination of assistance at that location.

Instructions for obtaining access to the EIV system are located on the EIV website at:

<http://www.hud.gov/offices/hsg/mfh/rhiip/eiv/eivhome.cfm>

**#70 –Obtaining Access to the Systematic Alien Verification for Entitlements (SAVE)
Program - August 2, 2007**

**UPDATED INFORMATION FOR OBTAINING ACCESS TO THE DEPARTMENT OF
HOMELAND SECURITY'S SAVE SYSTEM**

HUD's rental assistance is restricted to United States citizens and eligible non-citizens. Owners/management agents (O/As) are responsible for ensuring that the documents provided by non-citizen applicants are valid by verifying the information disclosed in these documents with the Department of Homeland Security (DHS).

The Systematic Alien Verification for Entitlements (SAVE) Program Branch of DHS provides O/As access to an automated verification system consisting of immigration status and employment eligibility verification information. In order to retrieve this information, owners must obtain an access code and user ID from DHS by submitting his or her request via email to Voneka.S.Bennett@hud.gov or via telephone at (202) 402-2055.

The owner's request must include the following information:

1. Name of the apartment complex
2. Contract number for the property
3. Physical address for the property (*no P.O. Box addresses*)
4. Phone number for the property
5. Fax number for the property
6. Name of the contact person
7. Email address for the contact person

HUD will forward this information to DHS requesting that the owner be granted access to the verification system. DHS will process the owner's request within approximately 3 business days and notify the owner directly via email that he or she has been given access to the verification system.

HUD Handbook 4350.3 REV-1 Change 2 Updates

1. Change 2 is incorporated into Handbook 4350.3 REV-1, *Occupancy Requirements of Subsidized Multifamily Housing Programs*, posted on HUDCLIPS at:

[http://hudclips.org/sub_nonhud/cgi/nph-brs.cgi?d=HSGH&s1=4350.3\[NO\]&SECT5=HSGH&SECT1=TXTHLB&l=50&u=../cgi/nph-wsdoc_run.cgi&p=1&r=1&f=S](http://hudclips.org/sub_nonhud/cgi/nph-brs.cgi?d=HSGH&s1=4350.3[NO]&SECT5=HSGH&SECT1=TXTHLB&l=50&u=../cgi/nph-wsdoc_run.cgi&p=1&r=1&f=S)

Questions pertaining to the Handbook should be sent to diane.r.hooten@hud.gov

2. It has been brought to our attention that there is an error in the date in Paragraph 3-13.A.2.f of the handbook pertaining to disabled students receiving Section 8 Assistance. This subparagraph should read:

f. is not a person with disabilities, as such term is defined in 3(b)(3)(E) of the United States Housing Act of 1937 (42 U.S.C.1437a(b)(3)(E)) and was not receiving section 8 assistance as of **November 30, 2005**. (See Definition E in Figure 3-6);

A page change will be issued to correct this error.

3. Appendix 4-A - HUD Model Lease for Subsidized Programs

A sentence was inadvertently left out of Paragraph 19, Size of Dwelling, when the revisions were made to this paragraph. The paragraph should read as follows:

19. Size of The Tenant understands that HUD requires the Dwelling Landlord to assign units **in accordance with the Landlord's written occupancy standards. These standards include consideration of unit size, relationship of family members, age and sex of family members and family preference.** If the Tenant is or becomes eligible for a different size unit, and the required size unit becomes available, the Tenant agrees to:

- a. move within 30 days after the Landlord notifies him/her that unit of the required size is available within the project; or
- b. remain in the same unit and pay the HUD-approved market rent.

A corrected version of the lease will be posted with the Handbook on HUDCLIPS.

4. We have received several questions regarding implementation of the lease revisions and whether the index will be updated and re-posted.

LEASE:

Owners must use the revised leases(s) issued in Change 2 for all new admissions.

Leases for current tenants must be executed by no later than the time of the next scheduled annual recertification and no sooner than the 60-day notice requirement discussed in paragraph 6-12 of the Handbook.

Since the revisions to the lease are issued by HUD Headquarters, no further approval from the local HUD office or the Contract Administrator is necessary.

INDEX

The index is currently being revised and will be posted with the Handbook on HUDCLIPS when the revisions are complete. We will post a Listserv notice when the index is available.

RHIIP Tip: Gross Rent Changes

For gross rent changes, the owner must place in the tenant file, a copy of the HUD-50059 reflecting any change in the tenant rent, utility reimbursement, total tenant payment or assistance payment.

See Paragraph 7-17 in *HUD Handbook 4350.3 REV-1, Occupancy Requirements for Subsidized Multifamily Housing Programs*, for information on Gross Rent Changes.

68 – Section 8 Project-Based Subsidy Payments (Notice to Owners, Management Agents and Contract Administrators) - July 23, 2007

Notice to Property Owners, Management Agents and Contract Administrators

Re: Section 8 Project Based Subsidy Payments

Effective July 16th, the Department began processing funding actions for subsidy contract amendments and renewals. Owners should begin to see their payments by the end of the month. The Department is in the process of assessing its funding requirements for the remainder of FY 2007. In the interim, however, for those owners needing money, the Department has provided guidance for expediting releases from their residual receipt and/or reserve for replacement accounts. Field offices have been directed to process these types of requests within one day.

The Department will continue to provide the owners with updates on the status of payments for the 4th quarter of FY 2007.

Summary of guidance for expediting releases from residual receipt and/or reserve for replacement accounts.

HUD (John L. Garvin) issued guidance on July 13, 2007, concerning the expedited processing for use of residual receipts and reserve for replacement funds to cover budget shortfalls.

Because some properties were experiencing delays in receiving Section 8 subsidy from HUD through no fault of their own, some had inadequate operating funds to meet the needs of the property. Under the terms of this guidance the Department allowed property owners to request HUD approval to use available residual receipts and/or reserve for replacement funds to meet mortgage and other necessary operating expenses of the property.

The following conditions applied:

- Residual receipts and/or reserve for replacement funds were only to be used if there are insufficient funds in the property's operating account to meet current expenses, including the mortgage payment.
- Owners had to use all available residual receipts funds prior to using replacement reserve funds.
- Residual receipts and/or replacement reserve funds were only to be used for mortgage payments and necessary operating expenses.
- To expedite processing, owners/management agents had to fax the Funds Authorization (Form HUD 9250) to the local HUD office. The request would then be processed within one business day and HUD would then fax the approved form to the owner/lender (if appropriate), or, if it's a direct or HUD-held loan, to HUD Headquarters. The form, with the original approval signature, would then be mailed to the lender.
- Inasmuch as these funds were needed to meet necessary operating and mortgage expenses, funds were to be released from the reserve for replacement account irrespective of normal minimum threshold balance requirements.
- The financial institution holding the funds released the funds based on the fax copy of the 9250 form to expedite the owner receiving the needed funds.
- All funds advanced to the owner under the emergency expedited processing procedures authorized by this memorandum, had to be promptly repaid to the reserve account when the Section 8 funds were received and the property had the needed funds to operate.

The guidance also permitted an owner of a 202 direct loan property without sufficient residual receipts or reserve for replacement funds to meet normal operating expenses to request that HUD consider temporarily suspending the mortgage offset payment. Such a request was to be sent to the local Multifamily HUD Office servicing the loan.

The expedited processing procedures remained in effect until January 13, 2008.

CHANGE TWO TO HANDBOOK 4350.3 REV-1 ISSUED

Change 2 to Handbook 4350.3 REV-1, *Occupancy Requirements of Subsidized Multifamily Housing Programs*, was issued on June 29, 2007, and is now posted at www.hudclips.org.

The issuance of Change 2 represents the Office of Multifamily Housing's commitment to ensuring that its guidance to program administrators of HUD subsidized multifamily housing projects is comprehensively updated on a regular basis. Furthermore, in response to the Office of Multifamily Housing's business partner requests, owners/management agents have 90 calendar days from the effective date of June 29, 2007, or September 24, 2007, to implement the changes requiring modifications to their TRACS software unless there are modifications that cannot be made at this time due to incompatibility with HUD's TRACS system. This information is included in the Transmittal issued with Change 2 along with a highlight of the changes made in each chapter, exhibit, appendix and the glossary.

Questions pertaining to the changes to the Handbook should be sent to Diane Hooten, Housing Project Manager, Office of Housing Assistance and Grant Administration, at Diane.R.Hooten@hud.gov.

Housing Notice H 2007-05 Regarding the Mark-to-Market (M2M) Program

On July 6th, HUD issued Notice H 2007-05, "Guidelines for Assumption, Subordination, or Assignment of Mark-to-Market (M2M) Program Loans in Transfer of Physical Assets (TPA) and Refinance Transactions".

As stated in the Notice, the guidelines amend and restate HUD's draft guidance dated June 2006, entitled "Draft Policy for Assumption and Subordination of Mark-to-Market ("M2M") Notes in Transfer of Physical Assets ("TPA") Transactions." The guidelines outlined in this Notice apply to any request to assume, subordinate, and/or assign a loan evidenced by a Note, and to waive the due-on-sale or refinance clause contained therein. This guidance also applies to requests to assume and/or subordinate loans originated under M2M's predecessor program, the Portfolio Reengineering Demonstration Program ("Demonstration Program"). The guidelines contained in this Notice are effective immediately for all such transactions.

The Notice can be found at www.hudclips.org, under WHAT'S NEW or under 2007 Housing Notices.

REMINDER!

Two-Day EIV Presentation
June 27-28, 2007

On **Wednesday, June 27, 2007 and Thursday, June 28, 2007**, HUD's Office of Housing Assistance and Grant Administration will present an informational course via webcast on the 7.0 Enterprise Income Verification (EIV) system for Multifamily. The two-day presentation will be conducted each day from 11:00 a.m. to 4:00 p.m. Eastern Daylight Savings Time.

URL to view webcast: www.hud.gov/webcasts/index.cfm Click on "Schedule of Upcoming Webcasts". Click on "6/27 or 6/28".

For external viewers (non-HUD staff), do not forget to make sure that you download the latest (free) version of RealPlayer from www.realplayer.com before the webcast. After you have downloaded the latest version of RealPlayer, go to www.hud.gov/webcasts/index.cfm and pull up any archived webcast to validate that you will be able to view the upcoming EIV webcast without any difficulty.

Answers to frequently asked questions about the webcast:

1. Q. Is the material covered on the second day, the same as on the first? Or is it different?
A. Different materials will be presented each day.
2. Q. How much does it cost?
A. There is no charge to view the webcast.
3. Q. Do I have to sign up for the webcast?
A. No, the webcast can be accessed through a computer at the URL address above.
4. Q. Where can the materials be found?
A. The materials (including the agenda and powerpoint slides) will be available on HUD's Multifamily EIV website under "What's Hot" at <http://www.hud.gov/offices/hsg/mfh/rhiip/eiv/eivhome.cfm> . They will also be available the morning of the webcast at the URL address used to view the webcast noted above. .
5. Q. Do I have to "**Log In**" to get to this training?
A. The webcast can be accessed through a computer at the URL address above.
6. Q. Will the presentation be archived, because I will not be available on those two days?
A. Yes, the webcast will be archived at the following website address that can be accessed at any time: www.hud.gov/webcasts/archives. There will also be a link to the archived webcasts from HUD's Multifamily EIV website at: www.hud.gov/offices/hsg/mfh/rhiip/eiv/eivhome.cfm.

REMINDER!

Mark Your Calendar for an Important EIV Event

NOTE: Change of URL to view broadcast

On **Wednesday, June 27, 2007 and Thursday, June 28, 2007**, HUD's Office of Housing Assistance and Grant Administration will present an informational course via webcast on the 7.0 Enterprise Income Verification (EIV) system for Multifamily. The two-day presentation will be conducted each day from 11:00 a.m. to 4:00 p.m. Eastern Daylight Savings Time. **Different material will be presented each day.** The course is targeted for HUD staff, property owners, management gents, and contract administrators. Topics that will be addressed are:

- Background of RHIP
- Role of EIV in the Overall RHIP Initiative
- Getting Access to EIV
- EIV Security Measures
- Using the EIV System
- EIV User Administration

URL Change: The webcast link for the impending course can be found at:
www.hud.gov/webcasts/index.cfm.
Click on "Schedule of Upcoming Webcasts". Click on "6/27 or 6/28".

For external viewers (non-HUD staff), make sure that you download the latest (free) version of RealPlayer from www.realplayer.com before the webcast. After you have downloaded the latest version of RealPlayer, go to www.hud.gov/webcasts/index.cfm and pull up any archived webcast to validate that you will be able to view the upcoming EIV webcast without any difficulty.

Mark Your Calendar for an Important EIV Event

On **Wednesday, June 27, 2007 and Thursday, June 28, 2007**, HUD's Office of Housing Assistance and Grant Administration will present an informational course via webcast on the 7.0 Enterprise Income Verification (EIV) system for Multifamily. The two-day presentation will be conducted each day from 11:00 a.m. to 4:00 p.m. Eastern Daylight Savings Time. The course is targeted for HUD staff, property owners, management gents, and contract administrators. Topics that will be addressed are:

- Background of RHIP
- Role of EIV in the Overall RHIP Initiative
- Getting Access to EIV
- EIV Security Measures
- Using the EIV System
- EIV User Administration

The webcast link for the impending course can be found on the Multifamily EIV homepage at: www.hud.gov/offices/hsg/mfh/rhiip/eiv/eivhome.cfm.

If you have any further questions, please call Kevin Garner, at 202-708-3000 x2057.

Thank you for your interest in HUD's EIV system for Multifamily Housing Programs.

RHIIP TIP ON CALCULATING INCOME FROM ASSETS FOR SPECIFIC TYPES OF ASSETS

For Balances held in retirement accounts:

Balances held in retirement accounts are counted as assets if the money is accessible to the family member. For individuals still employed, accessible amounts are counted even if withdrawal would result in a penalty. However, amounts that would be accessible only if the person retired are not counted.

IRA, Keogh, and similar retirement savings accounts are counted as assets, even though withdrawal would result in a penalty.

Include contributions to company retirement/pension funds:

- While an individual is employed, count only amounts the family can withdraw without retiring or terminating employment.
- After retiring or terminating employment, count as an asset any amount the employee elects to receive as a lump sum.

Include in annual income any retirement benefits received through periodic payments.

For further information and examples, please refer to Chapter 5 Paragraph **5-7 G4** of *HUD Handbook 4350.3 REV-1 Occupancy Requirements of Subsidized Multifamily Housing Programs*.

Limited English Proficiency (LEP) Frequently Asked Questions

The Office of Fair Housing and Equal Opportunity (FHEO) has posted two sets of frequently asked questions related to LEP:

1. Frequently Asked Questions on the Final LEP Guidance
2. LEP Frequently Asked Questions from the Multifamily Housing Industry Groups

The Final LEP Guidance was published in the January 22, 2007 Federal Register.

The FAQs and the Final LEP Guidance can be accessed through the following web address:

<http://www.hud.gov/offices/fheo/promotingfh/lep.cfm>

Important EIV Update Notification

After receiving the appropriate approval for access to HUD's Enterprise Income Verification (EIV) system for Multifamily Housing Program users, two additional steps must occur before data in EIV can be viewed. First, the appropriate EIV role must be assigned to the user's property(ies) and/or contract(s) available to the user in Web Access Secure Systems (WASS). Second, the user's property(ies) and/or contract(s) must be certified within EIV.

At this time, the certification of approved EIV Coordinators (with the HSC role) has been temporarily interrupted since the last certification date of March 29, 2007. This interruption is expected to continue for an additional two to three weeks. Therefore, EIV data will not be viewable by:

- EIV Coordinators who were approved for EIV Coordinator access by HUD's Multifamily Help Desk **before** March 29, 2007, but who did not perform the HSC role assignment to their property(ies) and/or contract(s) available to them in WASS until **after** March 29, 2007;
- EIV Coordinators who were only able to assign the HSC role to some of their properties/contracts available to them in WASS by the March 29, 2007 deadline, but not to all of them; and
- EIV Coordinator applicants who submitted their Coordinator Access Authorization form to the Multifamily Help Desk after March 29, 2007.

A message will be posted to the RHIIP Listserv, TRACSmial and on the Multifamily EIV website indicating the date that the certification process will be resumed.

Please note that until an EIV Coordinator's property(ies) and/or contract(s) has been certified within EIV, that EIV Coordinator will be unable to certify his or her user's property(ies)/contract(s) within EIV. For example, if your property/contract is not certified within EIV, and you have assigned the EIV User role (**HSU EIV-MF-EIV Non-HUD User**) to your staff who have provided you with an acceptable User Access Authorization Form (UAAF) and then you assigned that HSU role to the property(ies) and/or contract(s) for which your user is responsible, you will be unable to certify your user's property(ies) and/or contract(s) within EIV until you, the EIV Coordinator, has been certified in EIV.

Until such time as the Social Security (SS), Supplemental Security Income (SSI), and Dual Entitlement benefits information is made available to you within EIV, please use one of the following alternatives to verifying a tenant's benefits information.

- (1) Obtain tenant SS/SSI/Dual Entitlement benefits information from the Tenant Rental Assistance Certification System (TRACS). If you need assistance in locating these tenant benefit data within TRACS, please contact HUD's Multifamily Help Desk at 800-767-7588 for assistance; or,
- (2) Obtain a current Social Security Administration (SSA) benefits letter from the tenant that is dated within the last 120 days. A tenant can call SSA at 1-800-772-1213 to request a current benefit verification letter or request a benefit verification letter via SSA's Internet website at www.ssa.gov. There is no cost to the tenant for making these requests.

We apologize for this delay in service and we thank you for your patience.

NOTE: EIV Coordinators whose Coordinator Access Authorization Form (CAAF) was approved by the Headquarters MF EIV Team or HUD's Multifamily Help Desk within the last 12 months do not have to submit additional CAAFs for EIV approval and certification of additional properties/contracts. This revises previous guidance provided at the TRACS industry meeting held at Headquarters on April 11-12, 2007. HUD's Multifamily Help Desk can be reached at 800-767-7588.

For continued EIV updates, we encourage you to regularly visit our EIV System Update for Multifamily Housing Program Users web page at:
<http://www.hud.gov/offices/hsg/mfh/rhiip/eiv/sysupdates.cfm>.

#60 – Important EIV Coordinator Reminder - April 23, 2007

This is a reminder that EIV Coordinators must certify their EIV Users through the User Certification feature within the EIV system each calendar quarter. Since there is a 30-day grace period at the end of each quarter before an EIV User will lose their EIV access if not certified, the 30-day grace period for the previous calendar quarter (January 1, 2007 through March 31, 2007) will end on April 30, 2007. Therefore, EIV Coordinators must certify their EIV Users no later than April 30, 2007. For the current calendar quarter (April 1, 2007 through June 30, 2007), EIV Coordinators must certify their EIV Users no later than July 31, 2007, and so on.

As mentioned in a prior EIV Update RHIP Listserv message, EIV Coordinators must not use the User Maintenance functionality in EIV for any reason. Quarterly certification of an EIV User's property(ies) or contract(s) in EIV is performed in User Certification in EIV, not User Maintenance. For information on how to perform user certifications in EIV, please see Section 3 MF Housing Program User Administration of the Enterprise Income Verification (EIV 6.0) System User Administration Manual for Multifamily Housing Programs. If you need further assistance in understanding how to perform user certifications, please contact the Multifamily Help Desk at 800-767-7588.

For continuous EIV updates, please visit our EIV System Update for Multifamily Housing Program Users web page at:

<http://www.hud.gov/offices/hsg/mfh/rhip/eiv/sysupdates.cfm>.

Thank you for your interest in HUD's EIV System for Multifamily Housing Programs and for assisting the Department in continuing to reduce subsidy errors in HUD's rental assistance programs.

#59 – HUD Energy E-Newsletter - April 13, 2007

HUD Deputy Secretary Roy Bernardi sent out the following notice on April 5, 2007: Energy awareness continues to be an ongoing priority with the Department. Every year HUD spends more than \$4 billion to heat, cool and light the buildings assisted, insured or financed through our various programs. Improving the energy efficiency of these properties will increase comfort and housing affordability for building residents, as well as generate savings for HUD and our partners. HUD Secretary Jackson has created a Department-wide Energy Task Force to find ways to save energy, and a wide range of activities have been initiated by key program and support offices. The first issue of HUD's bi-weekly energy e-newsletter, called the "Energy Action Update," is available on HUD's website at <http://www.hud.gov/offices/cpd/energyenviron/energy/library/newsletters/index.cfm>. The newsletter contains timely information on the Department's energy efficiency activities, best practices and useful tips for reducing energy consumption. I encourage you to review the material to improve your understanding of what HUD is doing to promote energy efficiency. If you have any comments, questions or suggestions, please communicate with our Energy Action Team at energyaction@hud.gov.

#58 – Student Eligibility Q&As; New OIG Brochure; FY2007 Income Limits; and HUD Energy Training Webcast Series- March 27, 2007

1. NEW ITEMS POSTED ON THE RHIIP WEBSITE AT:

<http://www.hud.gov/offices/hsg/mfh/rhiip/mfhrhiip.cfm>

* A new set of Student Eligibility Restrictions Q&As was posted on March 23, 2007. These Q&As include guidance not covered in the Supplementary Guidance published in the April 10, 2006 Federal Register and replace the Q&As 4/12/06 Conf. Call Student Eligibility Restrictions that were previously posted.

* The Special Claims Processing Guide Frequently Asked Questions have been updated and were posted on February 26, 2007.

We encourage you to visit this website for other materials and information related to reducing errors in Housing's assistance programs.

2. NEW OIG BROCHURE - APPLYING FOR HUD HOUSING ASSISTANCE? THINK ABOUT THIS? IS FRAUD WORTH IT?

The Office of Inspector General (OIG) has posted a new brochure titled Applying for HUD Housing Assistance? Think About This? Is Fraud Worth It?, Form HUD-1141. This brochure is provided in both English and Spanish versions and replaces Form HUD-1140-OIG titled Things You Should Know.

Owners and management agents should have this new brochure available to provide to applicants and tenants.

The brochure is posted under Forms at:
www.hudclips.org

3. INCOME LIMITS FOR FY 2007

The new income limits for FY 2007 effective March 20, 2007, have been posted at:
<http://www.huduser.org>

4. HUD ENERGY TRAINING WEBCAST SERIES

Registrations (no cost) are now being accepted for the HUD Energy Training Webcast Series. HUD is offering four satellite broadcasts and live webcasts on energy efficiency and renewable energy technologies and techniques in affordable housing. Presented on-line in a series of four 3-hour modules, these webcasts offer the most current information and technical guidance on:

• Building Operations and Management: The First Step to Energy Efficiency. April 12

• Multifamily Retrofit and Remodeling Strategies. May 17

• Single Family Rehab and Retrofits: Focus on Low-Rise Buildings. June 14

• New Construction Techniques. Energy Star Qualified New Homes, Green Building and Beyond. September 13

All webcasts 1:00 - 4:00 PM EST

For more information about this training or to register for the training go to:
www.hudenergytraining.com

Forms HUD-9887 and HUD-9887-A Have Been Revised

As of February 2007, form HUD-9887, Notice and Consent for the Release of Information and form HUD-9887-A, Applicants/Tenants Consent to the Release of Information, have been revised. The Department of Health and Human Services (HHS) National Directory of New Hires (NDNH) has been added as a verification source. Once the NDNH data becomes available to multifamily owners and management agents (O/A), the tenants signature on the forms will give consent to the O/A to use NDNH data to verify their income. In addition, throughout the forms, O/As have been added as one of the parties the tenant is giving consent to for the release of information.

These revised forms must be used immediately.

The following is a list of all the revisions that were made to the forms:

Form(s)

Location
Revision

HUD-9887

HUD-9887-A Fact Sheet

HUD-9887-A Throughout the forms Handbook 4350.3 has been revised to Handbook 4350.3 Rev. 1

HUD-9887

HUD-9887-A Fact Sheet

HUD-9887-A Throughout the forms O/As are listed as being able to verify income information

HUD-9887-A Fact Sheet What Verification Involves First Paragraph of Text Expanded to make language conform to the regulation, at least 18 years of age and each family head, spouse, or co-head regardless of age,

HUD-9887

HUD-9887-A Who Must Sign the Consent Form Expanded to make language conform to the regulation, "at least 18 years of age and each family head, spouse, or co-head regardless of age,"

HUD-9887-A Fact Sheet What Verification Involves

Paragraph 1. Added HHS NDNH as a verification source What Verification Involves Paragraph 2. Added Form HUD-9887 Customer Protections First and Second Paragraphs Added Form HUD-9887-A HUD-9887

Top portion of the form Inserted a box for the full name and address of the O/A; if there is a management agent, that name and address must be inserted; if there is no management agent, only the owners name and address must be inserted Authority Inserted Section 217 of the Consolidated Appropriations Act of 2004 for the use of the NDNH data and in that paragraph and the one on Section 904 of the Stewart B. McKinney Homeless Assistance Amendments Act of 1988, as amended, added the use of the information specified in the laws Purpose Expanded to include the information that can be obtained from NDNH Consent Section Changed the words public agencies to federal and state agencies Agencies To Provide Information Included HHS NDNH as a verification source and added HUD Office of Inspector General (OIG) as one of the parties required to independently verify information HUD-9887-A Instructions to Owners Inserted the words, after obtaining the required applicants/tenants signature(s) Authority for Requiring Applicants/Tenants Consent to the Release of Information Corrected the Code of Federal Regulations (CFR) provision Failure to Sign the Consent Form Deleted the words, which require that the tenant pay the higher, HUD-approved market rent for the unit for failure to provide recertification information Signature of Applicant or Tenant & Date Deleted the words, and/or it has been explained to me.

1. RHIP TIP ON MEDICAL EXPENSES

Did you know that transportation expenses to/from treatment and lodging are eligible as medical expense deductions? These types of expenses may include the actual cost (e.g. bus fare) or, if driving in a car, a mileage rate based on IRS rules or other accepted standard. If the IRS mileage rate was used in calculating the transportation expense for driving a car, please refer to the 2007 mileage rate that was released by the IRS on November 1, 2006. The rate for computing deductible medical expenses has increased from 18 cents to 20 cents a mile. The IRS press release can be found at: <http://www.irs.gov/newsroom/article/0,,id=163828,00.html>

2. Notice of Closure of the Section 8 Expiring Contracts Mailbox

This is notification that due to the diminishing number of questions and comments being received, the Section 8 expiring Housing Assistance Payment (HAP) Contracts mailbox will no longer be available as of February 23, 2007. Since the mailbox was opened in the spring of 2001, numerous questions and comments were received which

Attention All Enterprise Income Verification (EIV) System Coordinators for Multifamily Housing Programs

* Effective immediately, EIV Coordinators must not use the User Maintenance functionality in the EIV system. Using this functionality in EIV will expire your Housing Coordinator (HSC) role in EIV. If you have expired your HSC role or your users' EIV roles (HSU) in EIV through User Maintenance, and you need to restore your access or your users' access, please contact HUD's Multifamily Help desk at 800-767-7588 for assistance.

Quarterly certification of your users' property(ies) or contract(s) in EIV is performed in User Certification in EIV, not User Maintenance.

* At the present time, social security benefit information for tenants under the Section 236 and Section 221(d)(3)BMIR programs (tenants not receiving Section 8, RAP or Rent Supplement) is not available in EIV. When certifying/recertifying these tenants, owners and management agents will need to use an alternative form of verification for social security benefits. See Handbook 4350.3 REV-1 Occupancy Requirements for Subsidized Multifamily Housing Programs, Appendix 5-3, Acceptable Forms of Verification, for suggested documents that can be used for verification purposes. Notification will be provided once this information becomes available in EIV.

Thank you for your cooperation.

#54 – Closure of Special Claims Comment Box - February 9, 2007

*****Notice of Closure of the Special Claims Comment Box*****

This is notification that due to the diminishing number of questions and comments being received, the Special Claims Comment box will no longer be available as of February 17, 2007. Since the box was opened in August 2006, receipt of questions and comments have been substantial and have helped the Department make improvements to the Guide as well as prepare and release Frequently Asked Questions (FAQs).

The Special Claims Guide has been developed to assist in the reduction of errors in the administration of HUDs rental housing assistance programs. The Special Claims Guide provides detailed guidance for the processing of Special Claim requests and is intended for use by HUD staff, Contract Administrators and Owners and Management Agents of Section 8 properties. This Guide expands on the guidance provided in Chapter 9 of HUD Handbook 4350.3 REV-1, Occupancy Requirements of Subsidized Multifamily Housing Programs. Your input through your questions and comments has helped improve the Guide. While the FAQs can serve as a resource the Department encourages the users of the Special Claims Guide to become more familiar with it rather than rely on the FAQs alone.

HUD Is Removed From GAO's High-Risk List

Today, a ceremony was held by HUD Secretary Jackson, HUD Deputy Secretary Bernardi, OMB Deputy Director for Management, Clay Johnson III, and OMB Controller, Linda Combs, recognizing HUD's success in being removed from GAO's "High-Risk" list. HUD's Rental Housing Assistance and Single Family Mortgage Insurance Programs have been on GAO's "High-Risk" list since they began reporting on high-risk programs in 1994 and elimination of the GAO high-risk designations is a milestone to celebrate. Secretary Jackson stated that this success was truly a HUD-team accomplishment, involving the efforts of HUD Headquarters and field office staff in the Offices of Housing/FHA, Public and Indian Housing (PIH), Chief Financial Officer (CFO), Policy Development and Research (PD&R), Chief Information Officer (CIO), General Counsel (GC), and others, thanking everybody for their efforts, professionalism and commitment to HUD's mission.

The following is the press-release announcing HUD's removal from GAO's high-risk list.

"GAO RECOGNIZES HUDS MANAGEMENT REFORMS"

First time in 13 years no HUD programs on GAO's High-Risk list

WASHINGTON - Citing significant financial and management reforms put in place by Housing and Urban Development Secretary Alphonso Jackson, the U.S. Government Accountability Office (GAO) today announced that two of HUD's critical housing programs have been removed from its "high-risk" list. GAO's report recognized HUD's progress in implementing management controls that have led to significant improvements to the Department's Single-Family Mortgage Insurance Programs and Rental Housing Assistance Programs.

This action marks the first time since 1994 that no HUD programs have been on GAO's "high-risk" list.

"HUD serves the nation best when all its programs are working effectively and efficiently," said Jackson. "GAO's removal of a high-risk designation for these two programs shines a bright light on HUD's efforts over the past six years to ensure taxpayer dollars are spent wisely and well."

In 2001, then-Deputy Secretary Jackson implemented the President's Management Agenda at HUD, putting in motion a reform plan to make sure the Single-Family Mortgage Insurance and Rental Housing Assistance Programs function more effectively. Under his leadership, the GAO in January 2005 recognized significant improvement in Single-Family Mortgage Insurance Programs and Rental Housing Assistance Programs. Since then, HUD's auditors from the Office of the Inspector General have also recognized the Department's progress by eliminating all material weakness issues in both program areas.

Single Family Housing Mortgage Insurance Program Reforms

Since 2001, the Department has made significant strides to reform The Federal Housing Administration's (FHA) single-family mortgage insurance programs. FHA made great progress in improving its lending, appraisal and property disposition controls, and enhancements to the timeliness, sophistication and predictive accuracy of its actuarial modeling. These improvements are ensuring a sound footing for FHA as it modernizes its programs in order to serve the 21st century homebuyer.

Rental Housing Assistance Program Reforms

In 2001, HUD issued the Quality Control for Rental Assistance Subsidies Determinations Study, which estimated that the Department's public housing and various tenant-based and project-

based rental assistance programs issued \$3.2 billion in gross annual improper payments attributable to program administrator errors and tenant underreporting of income.

To reduce improper rental assistance payments, HUD's Office of Public and Indian Housing and Office of Housing worked with their housing industry partners and tenant advocacy groups to improve program guidance, training and automated systems support. HUD developed and implemented the Enterprise Income Verification System (EIV) - a web-based, state of the art system - to share income data in other federal databases with public housing authorities to improve their income verification process. These collective actions led to a 60 percent decline in gross improper payments between 2001 and 2005. With full implementation of the use of EIV by all HUD program administrators in 2007, HUD will further reduce the remaining improper payment level. The money that had been paid in error is now being used to house more low-income families.

The EIV system has received significant recognition for its innovation in government, including helping HUD gain a "green" score under the President's Management Agenda scorecard in 2005 and winning the Government Computer News Gala Award in 2006.

To read the full GAO report visit: <http://www.gao.gov/new.items/d07310.pdf>

1. Section 8 Renewal Policy Guide:

On December 20, 2006, HUD issued the new instructions for the renewal of Section 8 project-based Housing Assistance Payment (HAP) contracts under Option 4, Renewal of Projects Exempted from the Office of Affordable Housing Preservation (OAHP). Specifically at initial and subsequent renewal the rents shall be set at the lesser of current rents as adjusted by the published Operating Cost Adjustment Factor (OCAF) or a budget based rent level. The implementation date for the lesser of test for subsequent renewal under Option 4 is April 19, 2007, 120 days from the date the new instructions were issued. This grandfathered in owners that have already submitted their renewal packages and provides HUD and the contract administrators time to notify owners of the new requirements.

Please refer to the Question and Answer below for additional clarification. In addition, if you have any questions feel free to contact Kerry Mulholland at (202) 402-2649. In addition, the material is posted on the web at www.hud.gov/offices/hsg/mfh/mfhsec8.cfm

Question: If a Section 8 HAP Contract has a renewal date after April 19, 2007, does the owner have until April 19, 2007, to submit the Option 4 renewal package under the old rules?

Answer: Yes. Under the grandfathering instructions, issued from HUD by email on January 18, 2007, an owner that selects Option 4 and submits its renewal package on or before April 19, 2007 is exempted from the lesser of test. The exception to this principle is the owner that submits its renewal package earlier than 120 days before the contract expiration date, for example 200 days, to avoid the lesser of test. They must comply with the new instructions.

2. New Name for Governments Official Web site:

The new official website address for the United States Federal Government is now <http://www.usa.gov> and <http://www.gobiernousa.gov> (Español).

Please share this with HUD's business partners and citizens who are looking for information or benefits from the Federal Government.

USA.gov replaces the former Firstgov.gov website.

#51 - EIV Update for Coordinators and Users - January 11, 2007

Enterprise Income Verification (EIV) Update
January 10, 2007

The Headquarters (HQs) EIV Team is faxing signed Coordinator Access Authorization Forms (CAAFs), received between August 1, 2006 and November 17, 2006, back to approved EIV Coordinators. This process is anticipated to continue through February 2007. Coordinators must make the FAX transmittal sheet and signed CAAF, as well as owner letters of approval available upon request for auditing and review purposes. For service issues or problems in EIV, please contact the Multifamily Help Desk at 1-800-767-7588 or Mf_Eiv@hud.gov.

The new schedule for certifying EIV Coordinators and Users within EIV is as follows: January 18, February 1 and 15, and March 1, 15, and 29, 2007. All users are expected to have access to the Social Security (SS) and Supplemental Security Income (SSI) benefits data contained in EIV on the next business day. Please note that EIV certification dates are subject to change.

Approved EIV Coordinators that have received an email from the Multifamily Help Desk indicating that they have been assigned the Housing Coordinator (HSC) role for access to the EIV system for multifamily housing programs, and have received written owner approval, must assign the HSC role to their properties and/or contracts by the next EIV certification date (January 18, 2007) to avoid delays in service.

If EIV Coordinators have assigned their properties and/or contracts to their HSC role and have received acceptable "User Access Authorization Forms" from their users, they must follow the instructions in the "Revised Instructions for Accessing EIV" on this website to obtain information on how to assign EIV access rights to their users through the Web Access Secure System (WASS.) If possible, they must ensure that the MF-EIV-Non-HUD User (HSU) role has been assigned to the properties and/or contracts that their Users are responsible for by the next EIV certification date (January 18, 2007) in order for them to get access on January 19, 2007 (the next business day).

When an EIV Coordinators or Users contract(s) or property(ies) has not been certified in EIV, such user will receive an error message that "No Contracts [Properties] are currently assigned to you for viewing Social Security and Supplemental Security Income reports." This message will be displayed when trying to do an Income Information search by Subsidy Contract or by Project Number in EIV.

Headquarters plans to conduct training on the current functionality of the EIV system (6.0 Release) for multifamily housing program users, as well as additional training after new functionality (new reports and modifications in the display of information on the various screens) is provided in the EIV system (7.0 Release). Training dates will be provided shortly. Thank you for your patience.

For more information on EIV, please see the Enterprise Income Verification (EIV) System for Multifamily Housing Program Users website at:
<http://www.hud.gov/offices/hsg/mfh/rhiip/eiv/eivhome.cfm>

#50 – RHIP Tip (Alimony or Child Support); and Page Changes to the Section 8 Renewal Policy Guide – December 27, 2006

RHIP Tip: Alimony or Child Support

Owners must count alimony or child support amounts awarded by the court unless the applicant certifies that payments are not being made and that he or she has taken all reasonable legal actions to collect amounts due, including filing with the appropriate courts or agencies responsible for enforcing payment.

The owner may accept printouts from the court or agency responsible for enforcing support payments, or other evidence indicating the frequency and amount of support payments actually received.

Child support paid to the custodial parent through a state child support enforcement or welfare agency may be included in the family's monthly welfare check and may be designated in different ways. In some states these payments are not identified as separate from the welfare grant. In these states, it is important to determine which portion is child support and not to count it twice. In other states, the payment may be listed as child support or as "pass-through" payments. These amounts must be counted as annual income.

When no documentation of child support, divorce, or separation is available, either because there was no marriage or for another reason, the owner may require the family to sign a certification stating the amount of child support received.

For further information, please refer to Chapter 5, Section 5, Paragraph 5-9.E of HUD Handbook 4350.3 REV-1 *Occupancy Requirements of Subsidized Multifamily Housing Programs*.

Page changes to the Section 8 Renewal Policy Guide

The material is posted on the web at: <http://www.hud.gov/offices/hsg/mfh/mfhsec8.cfm>

Explanation of Changes.

All changes have light grey shading to denote what has changed on the page unless a section was completely removed. The major changes are:

1. Establishes in Chapter One that the Section 8 Renewal Guide Book information collection requirements have been approved under the Paperwork Reduction Act of 1995.
2. Removes some confusing language from page 1 of Chapter Two.
3. Corrects a typographical error on page 2 of Chapter Two revised on May 5, 2006.

RHIP Tip: VERIFICATION REQUIREMENTS

Owners must verify all income, assets, expenses, deductions, family characteristics, and circumstances that affect eligibility or level of assistance.

Applicants and adult family members must sign consent forms to authorize the owner to collect information to verify eligibility, income, assets, expenses, and deductions. Applicants and tenants who do not sign required consent forms will not receive assistance.

Family members 6 years of age and older must provide the owner with a complete and accurate social security number. For any members of the family who do not have a social security number, the applicant or family member must certify that the individual has never received a social security number. This requirement is described in paragraphs 3-9 and 3-28 of Handbook 4350.3 REV-1.

The owner must handle any information obtained to verify eligibility or income in accordance with the Privacy Act.

For further information, please refer to Chapter 5, Section 3, Paragraph 5-12.A of HUD Handbook 4350.3 REV-1 *Occupancy Requirements of Subsidized Multifamily Housing Programs*.

Guidelines for Calculating and Retaining Section 236 Excess Income Not Extended

On September 1, 2004, the Final Rule on retention of excess income in the Section 236 program was published in the Federal Register. The Final Rule amended the regulations governing the Section 236 program by establishing the terms and procedures for owners to participate in retaining some or all of their excess rental changes (Excess Income) for project or non-project use. Guidance for these activities was previously provided in a series of notices, the last of which was Notice H 05-15 which will not be extended. Until Handbook 4350.1, *Multifamily Asset Management and Project Servicing*, is updated to include the guidance previously provided in the Notices, the guidance published in the Final Rule should be used.

#48 –EIV Access Responsibilities Transferred – November 20, 2006

Effective today, November 20, 2006, persons applying for EIV access as an EIV Coordinator must submit their EIV Coordinator Access Authorization Form (CAAF) to the Multifamily Help Desk. The form can either be submitted via email in a PDF format or in a compressed picture format such as GIF or JPG to mf_eiv@hud.gov or by fax to 202-401-7984. For additional instructions on applying for EIV access, see the *Instructions for Applying for EIV Access for Multifamily Housing Programs*, located on the Multifamily EIV Web site at: <http://www.hud.gov/offices/hsg/mfh/rhiip/eiv/eivhome.cfm>

Also effective on November 20, 2006, any inquiries or questions relating to the EIV system for Multifamily Housing Programs or previously submitted application forms must be directed to the Multifamily Help Desk at 1-800-767-7588 or by email at Mf_Eiv@hud.gov.

#47 – IMPORTANT- EIV Access Responsibilities Transferred – November 15, 2006

On November 14, 2006, a message was posted to this Listserv indicating that on November 20, 2006, the Multifamily Help Desk will begin accepting Coordinator Access Authorization Forms (CAAFs) from individuals applying for EIV access as an EIV Coordinator. The Multifamily Help Desk is beginning to receive CAAF, telephone calls and electronic messages.

The purpose of this message is to emphasize that the Multifamily Help Desk will **NOT** accept any Coordinator Access Authorization Forms, telephone calls or email messages **until November 20, 2006**. Prior to November 20, 2006, all Coordinator Access Authorization Forms, telephone inquiries and electronic messages must be sent to the Multifamily EIV Team. Forms may be faxed to the Multifamily EIV Team at 202-708-3104 or sent in PDF format or in a compressed picture format such as GIF or JPG to Mf_Eiv@hud.gov. Telephone inquiries are to be made to 202-708-0120 through Friday, November 17, 2006. Thank you for your cooperation.

#46 - EIV Access Responsibilities Transferred – November 14, 2006

Effective November 20, 2006, persons applying for EIV access as an EIV Coordinator must submit their EIV Coordinator Access Authorization Form to the Multifamily Help Desk. The form can either be submitted via email in a PDF format or in a compressed picture format such as GIF or JPG to mf_eiv@hud.gov or by fax to 202-401-7984. For additional instructions on applying for EIV access, see the *Instructions for Applying for EIV Access for Multifamily Housing Programs*, located on the Multifamily EIV Web site at:
<http://www.hud.gov/offices/hsg/mfh/rhiip/eiv/eivhome.cfm>

Also effective on November 20, 2006, any inquiries or questions relating to the EIV system for Multifamily Housing Programs must be directed to the Multifamily Help Desk at 1-800-767-7588 or by email at Mf_Eiv@hud.gov.

Enterprise Income Verification (EIV) Access Special Alert

For EIV Coordinators who received an email from HUD Headquarters indicating that they have been assigned the **Housing Coordinator (HSC)** role for access to the EIV system for multifamily housing programs, and have received written owner approval, please assign the HSC role to your properties and/or contracts no later than November 1 to get access to EIV by November 3. If unable to obtain approval by this time, please obtain approval and assign the HSC role to your properties and/or contracts by November 15 for access to EIV by November 16 and by the day before each of the following dates to ensure EIV access by that date: November 30, December 15, and December 28. These dates are subject to change.

If you (the EIV Coordinator) have assigned your properties and/or contracts to your HSC role and have received acceptable User Access Authorization Forms from your users, please follow the instructions in the *Updated Instructions for Applying for EIV Access for Multifamily Housing Programs* on the following website for information on how to assign, in WASS, EIV access rights to your users: <http://www.hud.gov/offices/hsg/mfh/rhiip/eiv/eivhome.cfm>.

If possible, ensure that the **Non-HUD User (HSU)** role has been assigned to the properties and/or contracts that the EIV Users are responsible for no later than November 1 in order for them to get access to EIV by November 3. If this cannot be completed by November 1, it will need to be completed by November 15 for access to EIV by November 16 and by the day before of each of the following dates to ensure EIV access by that date: November 30, December 15 and December 28. These dates are subject to change. Effective 1/2007, EIV Coordinators will be required to certify their users on a quarterly basis. The EIV User Manual scheduled to be released soon provides instructions on how to certify these users in EIV.

Any questions can be directed to the Multifamily EIV Team at 202-708-0120.

#44 – Medicare Open Enrollment Begins - October 24, 2006

Medicare Open Enrollment Begins on November 15, 2006:

Medicare recipients are encouraged to take the time during October to complete the "Rx Enrollment Check-Up" in the attached publications to help them decide whether the coverage under their current Medicare health or prescription drug plans will meet their needs in 2007. If they are satisfied with their current plan, they do not need to re-enroll. If they are not satisfied with their current plan they can enroll in a different plan during the open enrollment period that begins November 15, 2006 and ends on December 31, 2006.

Enterprise Income Verification (EIV) System Update

Currently, authorized EIV Coordinators for Multifamily Housing programs may be experiencing some difficulties in accessing the system. These include: **1)** no longer seeing the link to the "Enterprise Income Verification" system in Secure Systems; **2)** receiving a "**Login Failed**" error message when clicking on the link to the EIV system in Secure Systems; and **3)** no longer seeing the Income Information search options (i.e., by Project Number, by Subsidy Contract, and by Head of Household) within the EIV system.

We are aware of such problems and are in the process of correcting these, as well as other system errors described in our previous Listserv message of 10/05/06. For details, see our EIV System Updates for Multifamily Housing Programs Users web page at: <http://www.hud.gov/offices/hsg/mfh/rhiip/eiv/sysupdates.cfm>.

Our goal is to have all of these issues resolved before the Social Security (SS) and Supplemental Security Income (SSI) benefits data become available within EIV on October 29, 2006. Thank you for your patience.

#42 - Mark-to-Market (M2) Program Extension - October 13, 2006

Mark-to-Market (M2M) Program Extended Through November 17, 2006

The following email was issued from the Office of Affordable Housing Preservation's Resource Desk on October 4, 2006:

Since appropriations including HUD's fiscal 2007 budget were not passed prior to the end of the current fiscal year (the fiscal year ended Sept 30), Congress has passed a Continuing Resolution (CR) to continue all HUD operations (which includes the continuation of the Mark-To-Market program) from Oct 1 through Nov 17. The language includes the authority to continue receiving, assigning, and processing project referrals during the Continuing Resolution period.

Referrals from the Multifamily HUD Offices should be on form HUD-9624 instead of the old form HUD-9936 or other previous versions of the Referral. In addition, Interim M2M Housing Assistance Payment (HAP) contracts should be under Section 514 and should be requested from the HUD Office as soon as possible after the referral. This will insure the property is properly under commitment for the M2M Restructure program.

We will keep you advised as to the status after November 17, 2006, when we are hopeful the appropriations Bill will be approved or a new CR will be approved and our authorities extended.

#41 - EIV Sign-Up – October 10, 2006

This is a correction to the Listserv #40 posting made October 5th regarding the article “**Sign Up For EIV.**” Reference was made in the article to the EIV Housing Coordinator as the “**HSU**” that should be instead the “**HSC**” for Housing **Coordinator**.

The article should read as follows:

There is still time to get access to the EIV system for purposes of verifying tenant SS/SSI benefits data. For those of you that did not submit an EIV Coordinator Access Authorization Form (CAAF) by September 18, 2006 in order to gain access into the system by September 29, 2006, you can still get access to EIV. Just complete the CAAF and submit it by email to Mf_Eiv@hud.gov or fax it to the HQ MF EIV Team at 202-708-3104 for processing. HUD's goal is to grant access to EIV, as soon as possible, to everyone who needs such access in performing income verifications. Therefore, it is important that you obtain the necessary owner written approval authorizing your access, as soon as possible, so that you may assign the **EIV Housing Coordinator (HSC)** role to your properties and begin incorporating the use of EIV into your day-to-day operations.

EIV System Error Messages:

"No Contracts are currently assigned to you for viewing Social Security and Supplemental Security Income reports"

AND

"EIV Application Error Message"

For those of you that have received an email from HUD Headquarters indicating that you have access to the Enterprise Income Verification (EIV) system for multifamily housing programs, and you have assigned the EIV Housing Coordinator role (HSC) to your property(ies) as instructed by that email, you may be receiving an error message in EIV that **"No Contracts are currently assigned to you for viewing Social Security and Supplemental Security Income reports"** when trying to do an Income Information search by Subsidy Contract or by Project Number. Alternatively, you may be receiving an **"EIV Application Error Message"** when trying to do an Income Information search by Project Number. We are aware of these technical errors and are in the process of resolving these problems. Please check the system daily for system availability. We apologize for any inconvenience this may have caused.

SS/SSI Benefit Data in EIV:

Currently, SS and SSI benefits data are not available for viewing in EIV. This delay is due to the time that it takes to match the data contained in the Tenant Rental Assistance Certification System (TRACS) with the data from the Social Security Administration (SSA). During this transition period when SS and SSI benefits data are not available for the purpose of conducting tenant recertifications of family income, please use tenant-provided SS/SSI benefit letters dated within the last 120 days to satisfy income verification requirements.

Sign Up For EIV:

There is still time to get access to the EIV system for purposes of verifying tenant SS/SSI benefits data. For those of you that did not submit an EIV Coordinator Access Authorization Form (CAAF) by September 18, 2006 in order to gain access into the system by September 29, 2006, you can still get access to EIV. Just complete the CAAF and submit it by email to Mf_Eiv@hud.gov or fax it to the HQ MF EIV Team at 202-708-3104 for processing. HUD's goal is to grant access to EIV, as soon as possible, to everyone who needs such access in performing income verifications. Therefore, it is important that you obtain the necessary owner written approval authorizing your access, as soon as possible, so that you may assign the EIV Housing Coordinator (HSU) role to your properties and begin incorporating the use of EIV into your day-to-day operations.

Publications:

On October 2, 2006, a Federal Register notice (FR-5103-N-01) was posted at www.hudclips.org regarding certain Operating Cost Adjustment Factors for 2007 for Multifamily Housing Project-Based Section 8 rent adjustments at contract renewal under Section 524 of the Multifamily Assisted Housing Reform and Affordability Act of 1997 (MAHRA).

This notice establishes annual factors used in calculating rent adjustments under section 524 of the Multifamily Assisted Housing Reform and Affordability Act of 1997 (MAHRA) as amended by the Preserving Affordable Housing for Senior Citizens and Families into the 21st Century Act of 1999, and under the Low-Income Housing Preservation and Resident Homeownership Act of 1990 (LIHPRA). The effective date is February 11, 2007.

Please click on the following link to view the federal register notice:
http://www.hudclips.org/sub_nonhud/cgi/pdf/16182.pdf)

SPECIAL NOTICE

The TASS system has been transitioned into the Enterprise Verification System.

PIH Users Click here

<http://www.hud.gov/offices/pih/programs/ph/rhiip/uivsystem.cfm>

Multifamily Housing Users Click here

<http://www.hud.gov/offices/hsg/mfh/rhiip/eiv/eivhome.cfm>

#38 - FY 2007 Fair Market Rents Published - September 29, 2006

Fiscal Year (FY) 2007 Fair Market Rents Published

The Fair Market Rents (FMRs) for FY 2007 were recently published in the Federal Register. The effective date is October 1, 2006.

You can view the FY2007 FMRs at:

<http://a257.g.akamaitech.net/7/257/2422/01jan20061800/edocket.access.gpo.gov/2006/pdf/06-8273.pdf>

APPLICABILITY OF STUDENT RULE

Does the student rule published in the Federal Register on December 30, 2005, apply to all individuals enrolled at an institution of higher education or does it only apply to persons under the age of 24?

The student rule applies to all individuals enrolled as students at an institution of higher education for the purpose of obtaining a degree, certificate, or other program leading to a recognized educational credential except for a student who is living with his/her parents who are applying for or receiving section 8 assistance.

Part 327(a), amended by Public Law 109-249, only applies to individuals under the age of 24 unless the individuals are students who are living with his/her parents who are applying for or receiving section 8 assistance.

“No section 8 assistance shall be provided to any individual who:

- Is enrolled as a student at an institution of higher education;
- Is under the age of 24;
- Is not a veteran of the United State military;
- Is unmarried;
- Does not have a dependent child;
- Is not a person with disabilities, as such term is defined in section 3(b)(3)(F) of the United States Housing Act of 1937 (42 U.S.C. 1437a(b)(3)(E)) and was not receiving assistance under such section 8 as of November 30, 2005; and
- Is not otherwise individually eligible, or has parents who, individually or jointly, are not eligible on the basis of income to receive section 8 assistance.”

Part 327(b) applies to all individuals enrolled as students at an institution of higher education unless the student is living with his or her parents who are applying for or receiving Section 8 assistance or is a person over the age of 23 with dependent children.

“Financial assistance, in excess of amounts received for tuition that an individual receives under the Higher Education Act of 1965, from private sources, or from an institution of higher education is considered income for that individual, except for persons over the age of 23 with dependent children.”

ITEM OF INTEREST:

The Office of Multifamily Housing posted a document on the HUD Multifamily RHIIP webpage (<http://www.hud.gov/offices/hsg/mfh/rhiip/mfhrhiip.cfm>) that archived posting #31-35 from the RHIIP Listserv. We recently received feedback that our policy of compiling every ten postings into once archive document was not efficient; therefore, we will develop an archive document after every five postings. If you have any suggestions on ways to improve the RHIIP Listserv, please feel free to email MFH_RHIIP_LISTSERV@HUD.GOV.

Deadline for Elimination of TASS Extended One Week

The Tenant Assessment Subsystem (TASS) used for income verification will be eliminated on September 29 instead of September 22. Once TASS is eliminated on September 29, the Enterprise Income Verification (EIV) System will be the only web-based system available to owners, management agents and service bureaus to verify social security and supplemental security income benefit information. It is anticipated that new hires, wage, and unemployment compensation data will be added into EIV for owners, management agents and service bureaus to use beginning in late 2006.

EIV Coordinator Access Authorization Forms Must Be Submitted By September 18 for Access to EIV by September 29

In order to use EIV, owners, agents and service bureaus must apply for EIV access rights by following the instructions found at http://www.hud.gov/offices/hsg/mfh/rhiip/eiv/eivhome.cfm_and completing either a Coordinator Access Authorization Form or a User Access Authorization Form. Coordinator Access Authorization Forms must be submitted to HUD Headquarters by fax at 202-708-3104 or by email at Mf_Eiv@hud.gov.

HUD's goal is to provide EIV access rights by September 29 to all EIV Coordinator applicants who submit complete and acceptable Coordinator Access Authorization Forms by September 18. Once EIV Coordinator applicants receive notification that they have EIV access rights, they may begin processing User Access Authorization Forms from their EIV User applicants.

WARNING: For security reasons, HUD will be removing access to EIV for anyone who assigned themselves the Coordinator or User role in EIV. If you assigned yourself EIV access as a Coordinator without submitting a Coordinator Access Authorization Form to HUD Headquarters or assigned staff as EIV Users without receiving a User Access Authorization Form from the staff needing User access rights, EIV access will be removed until such time as the proper application forms are submitted and processed.

What will be available in EIV immediately after TASS is eliminated?

In transitioning from TASS to EIV, which currently provides SS and SSI benefit data, between September 29, 2006 (the date TASS is eliminated) and approximately October 22, 2006, SS and SSI benefit data will not be available for viewing in EIV due to the time it takes to match the data in the Tenant Rental Assistance Certification System with the data from the Social Security Administration. During this transition period, users will be able to see only tenant information by using the "Head of Household" link; the income discrepancy report and the ability to search by recertification date will not be available. During this period when SS and SSI benefit data may not be available for the purpose of conducting tenant recertifications of family income, please use tenant-provided SS/SSI benefit letters dated within the last 120 days to satisfy income verification requirements.

#35 – RHIP Tip (Assets); and Housing Notice H 06-11 (Repayments) – September 1, 2006

RHIP Tip:

1. Assets are items of value that may be turned into cash. A savings account is a cash asset. The bank pays interest on the asset. The interest is the *income* from that asset.
2. Some tenants have assets that are not earning interest. A quantity of money under a mattress is an asset: it is a thing of value that could be used to the benefit of the tenant, but under the mattress it is not producing income.
3. Some belongings of value are not considered assets. Necessary personal property is not counted as an asset.

For further information, please refer to Exhibit 5-2 of *HUD Handbook 4350.3 REV-1 Occupancy Requirements of Subsidized Multifamily Housing Programs* that summarizes the items that are considered assets and those that are not.

PUBLICATIONS

Housing Notice H06-11, issued August 8, 2006, regarding “Prepayments Subject to Section 250(a) of the National Housing Act” can be viewed at www.hudclips.org.

#34 - Exemption for Student with Disabilities – August 8, 2006

Students with Disabilities Receiving Section 8 as of November 30, 2005, Exempt From Section 8 Restriction

On July 27, 2006, President Bush signed into law an amendment that exempts college students with disabilities from the restriction on providing Section 8 rental assistance to college students if the student with the disability was receiving the assistance as of November 30, 2005. The text of the amendment is as follows:

SECTION 1. EXEMPTION OF PERSONS WITH DISABILITIES FROM SECTION 8 RENTAL ASSISTANCE PROHIBITION

Subsection (a) of section 327 of Public Law 109-115 (119 Stat. 2466) is amended –

- (1) in paragraph (5), by striking “and” at the end;
- (2) by redesignating paragraph (6) as paragraph (7); and
- (3) by inserting after paragraph (5) the following new paragraph:

“(6) is not a person with disabilities, as such term is defined in section 3(b)(3)(E) of the United States Housing Act of 1937 (42 U.S.C.1437a(b)(3)(E)) and was not receiving assistance under such section 8 as of November 30, 2005”.

The exemption is effective as of July 27, 2006. The Offices of Housing and Public and Indian Housing will be issuing a notice to this effect in the near future.

PUBLICATIONS

The latest RHIP Newsletter has been posted on the HUD Multifamily RHIP website. Articles include "Locking out Tenant Fraud in Multifamily Housing Programs", "GAO 05-224 Audit in Brief on HUD Rental Assistance and Challenges in Measuring and Reducing Improper Rent Subsidies", as well as a message from Assistant Secretary for Housing - FHA Commissioner Brian Montgomery on the achievements HUD has made in reducing improper payments. You can find this newsletter, as well as other information relating to the RHIP initiative at <http://www.hud.gov/offices/hsg/mfh/rhip/mfhrhip.cfm>.

RHIP Tip: Income from a Business

When calculating annual income, owners must include the net income from operation of a business or profession including self-employment income. Net income is gross income less business expenses, interest on loans, and depreciation computed on a straight-line basis.

1. In addition to net income, owners must count any salaries or other amounts distributed to family members from the business, and cash or assets withdrawn by family members, except when the withdrawal is a reimbursement of cash or assets invested in the business.
2. When calculating net income, owners must not deduct principal payments on loans, interest on loans for business expansion or capital improvements, other expenses for business expansion, or outlays for capital improvements.
3. If the net income from a business is negative, it must be counted as zero income. A negative amount must not be used to offset other family income.

For further information, please refer to Paragraph 5-6G of *HUD Handbook 4350.3 REV-1 Occupancy Requirements of Subsidized Multifamily Housing Programs*.

Multifamily Housing Program Users Can Now Apply for Access to the Enterprise Income Verification (EIV) System

On July 17, 2006, the Headquarters Multifamily EIV Team became operational, on a temporary basis, to assign access authorization rights to EIV Coordinators. It is expected that the Multifamily Helpdesk will eventually assume the role of assigning and re-assigning access rights to EIV. The forms and instructions for applying for EIV access authorization rights are contained on the new Enterprise Income Verification (EIV) system website for Multifamily Housing Program users. Accessible via Housing's Rental Housing Integrity Improvement Project (RHIP) website (<http://www.hud.gov/offices/hsg/mfh/rhiip/mfhrhiip.cfm>), the new EIV website at: <http://www.hud.gov/offices/hsg/mfh/rhiip/eiv/eivhome.cfm> currently provides EIV system capability and background information, instructions for accessing the EIV system data, required certification application forms, and system security measure requirements. An EIV System User Manual will also be available on the EIV website in the near future.

Once owners and management agents obtain access authorization rights to EIV they will be able to obtain social security and supplemental security income benefit information to help verify tenant-reported income that heretofore had only been available to them through the Tenant Assessment Subsystem which is scheduled to be eliminated on September 22, 2006. Furthermore, it is also intended that owners and management agents will be able to obtain through EIV, beginning on September 25, 2006, the Department of Health and Human Services' National Directory of New Hires Data which will provide additional information such as family new hire information, wage and unemployment insurance benefit data. The Department believes EIV is a critical tool to ensure that the right benefits go to the right persons and encourages owners and management agents to apply for EIV access authorization rights as soon as possible.

#30 – RHIP Tip (Assigning Units Smaller/Larger); and Items of Interest (Extra Help/Low Income Subsidy (LIS) Outreach Toolkit) – July 12, 2006

RHIP Tip: Assigning a Smaller Unit Than Required

An owner may assign a family to a smaller unit size than suggested by the owners' occupancy policies if the family requests the smaller unit and if all of the following apply:

- The family is eligible for the smaller unit based upon the number of family members, and occupancy of the smaller unit will not cause serious overcrowding;
- Assigning a smaller unit results in a lower rent payment for the occupant in a Section 236 or BMIR (Below Market Interest Rate) property; and
- The assignment will not conflict with local codes.

Assigning Units Larger Than Required:

An owner may assign a family to a larger unit than suggested by the owner's occupancy standards if one of the following conditions exists:

- No eligible family in need of the larger unit is available to move into the unit within 60 days, the property has the proper size unit for the family but it is not currently available, and the family agrees in writing to move at its own expense when a property size unit becomes available.
- A family needs a larger unit as a reasonable accommodation for a family member who is a person with a disability.

However, a single person must not be permitted to occupy a unit with two or more bedrooms, except for the following persons:

- A person with a disability who needs the larger unit as a reasonable accommodation.
- A displaced person when no appropriately sized unit is available.
- An elderly person who has a verifiable need for a larger unit.
- A remaining family member of a resident family when no appropriately sized unit is available.

Please reference Chapter 3 Paragraph **3-23 F & G** of *HUD Handbook 4350.3 REV-1 Occupancy Requirements of Subsidized Multifamily Housing Programs*.

ITEMS OF INTEREST:

The Department of Health and Human Services recently sent HUD an email with the following information:

On Thursday, July 6, 2006, the Centers for Medicare & Medicaid Services (CMS) announced the publication of an Extra Help/Low Income Subsidy (LIS) Outreach Toolkit. The outreach and education initiatives outlined in this plan are designed to identify all remaining likely LIS eligible beneficiaries who have not yet applied for the LIS or joined a plan; ensure that these beneficiaries complete the LIS application process; and

encourage them to make an active choice of Medicare drug plans. CMS will strive to coordinate to the fullest extent possible with relevant federal, state and local partners to maximize the effectiveness and return on investment of all outreach efforts.

Estimates show that approximately 3 million Medicare beneficiaries remain who are likely to qualify for the LIS, but have not yet applied for the LIS or enrolled in a Medicare drug plan. These beneficiaries are scattered throughout the country and are more likely to be less educated, more isolated from their communities, and members of minority groups. Because of these factors, they are traditionally hard to reach due to barriers posed by literacy, geography, mobility, language, or culture. Identifying, qualifying and enrolling these remaining eligible beneficiaries in Medicare prescription drug coverage is a priority.

There is a Special Enrollment Period (SEP) for people who qualify for the LIS. Those who qualify will be able to join a Medicare drug plan immediately without paying a penalty, and will not have to wait for the next open enrollment period. This SEP for people who qualify for the LIS began on May 16, 2006, and will continue through November 15, 2006. The Toolkit is available at the following website address:
<http://www.cms.hhs.gov/center/partner.asp>.

#29 – Correction to Special Claims Guide Posting – July 7, 2006

Special Claims Processing Guide

On Thursday, July 6th, a RHIP listserv posting was made regarding the Special Claims Processing Guide. The listserv posting is shown below. Please note that there is a correction to the mailbox referenced in the attached memorandum. The correct mailbox address to submit questions regarding the Special Claims Guide is Special_Claims_Comment_Box@hud.gov.

#28 –RHIP Tip (Elderly/Disabled Families); and Special Claims Guide – July 6, 2006

RHIP Tip:

An elderly or disabled family is any family in which the head, spouse, or co-head (or the sole member) is at least 62 years of age or a person with disabilities. Each elderly or disabled family receives a \$400 family deduction. Because this is a "family deduction" each family receives only one deduction, even if both the head and spouse are elderly or disabled.

Please reference Chapter 5 Paragraph 5-10.E of *HUD Handbook 4350.3 REV-1 Occupancy Requirements of Subsidized Multifamily Housing Programs*.

PUBLICATIONS:

The Special Claims Processing Guide has been approved and is posted on www.hudclips.org under "WHAT'S NEW" and in the Hudclips library under "Guidebooks".

The Guide has been developed to assist in the reduction of errors in the administration of HUD's rental housing assistance programs. Detailed guidance is provided for the processing of Special Claims requests and is intended for use by HUD staff, Contract Administrators and Owners and Management Agents of Section 8 project-based contracts. This Guide expands on the guidance provided in Chapter 9 of HUD Handbook 4350.3 REV-1, *Occupancy Requirements of Subsidized Multifamily Housing Programs*. The Office of Housing Assistance Contract Administration Oversight issued an implementation memorandum dated July 5, 2006, copy attached, with an effective implementation date of August 1, 2006, **for all projects covered by the Guide.**

#27- RHIP Tip (Deduction for Disability Assistance Expense) - June 30, 2006

RHIP Tip:

1. Families are entitled to a deduction for unreimbursed, anticipated costs for attendant care and “auxiliary apparatus” for each family member who is a person with disabilities, to the extent these expenses are reasonable and necessary to enable any family member 18 years of age or older who may or may not be the member who is a person with disabilities to be employed.
2. This deduction is equal to the amount by which the cost of the care attendant or auxiliary apparatus exceeds 3% of the family’s annual income. However, the deduction may not exceed the earned income received by the family member or members who are enabled to work by the attendant care or auxiliary apparatus.
3. If the disability assistance enables more than one person to be employed, the owner must consider the combined incomes of those persons. For example, if an auxiliary apparatus enables a person with a disability to be employed and frees another person to be employed, the allowance cannot exceed the combined incomes of those two people.

The following are examples of an eligible disability assistance expense:

The payments made on a motorized wheelchair for the 42-year-old son of the head of the family enable the son to leave the house and go to work each day on his own. Prior to the purchase of the motorized wheelchair, the son was unable to make the commute to work.

Payments to a care attendant to stay with a disabled 16-year-old child allow the child’s mother to go to work every day.

Please reference Chapter 5 Paragraph 5-10.C.1-3 of *HUD Handbook 4350.3 REV-1 Occupancy Requirements of Subsidized Multifamily Housing Programs*.

#26 – RHIP Tip (Income from Assets); Housing Notice H06-06 (Reinstatement of Policy Permitting Increases of Project Rental Assistance Contract (PRAC) Reservations Prior to Occupancy Under the Section 202 Supportive Housing for the Elderly and the Section 811 Supportive Housing for Persons with Disabilities Programs); and Ordering HUD Pamphlets – June 19, 2006

RHIP Tip:

Commonly, when a family receives a large amount of money, a lump sum payment, the family will put the money in a checking or savings account, or will purchase stocks or bonds or a CD. Owners must count lump sum payments received by a tenant as assets. Examples of lump sum payments include the following:

Inheritances;

Capital gains;

Lottery winnings paid in one-payment;

Cash from the sale of assets;

Insurance settlements (including health and accident insurance, workers compensation, and personal and property losses); and

Any other amounts that are received in one-time lump sum payments.

A lump sum payment is counted as an asset only as long as the family continues to possess it. If the family uses the money for something that is not an asset - a car or a vacation or education- the lump sum must not be counted.

It is possible that a lump sum or an asset purchased with a lump sum payment may result in enough income to require the family to report the increased income before the next regularly scheduled annual recertification. But this requirement to report an increase in income before the next annual recertification would not apply if the income from the asset was not measurable by the tenant (e.g., gems, stamp collection).

Please reference Chapter 5 Paragraph 5-7.G3 of *HUD Handbook 4350.3 REV-1 Occupancy Requirements of Subsidized Multifamily Housing Programs*.

PUBLICATIONS:

Housing Notice H06-06 was issued June 8, 2006 and expires June 30, 2007. This notice is regarding the “Reinstatement of Policy Permitting Increases of Project Rental Assistance Contract (PRAC) Reservations Prior to Occupancy Under the Section 202 Supportive Housing for the Elderly and the Section 811 Supportive Housing for Persons with Disabilities Programs.” (Cross Reference: Notice H 96-102, Handbooks 4571.4, and 4571.5). The notice can be viewed on www.hudclips.org.

ITEMS OF INTEREST:

To order HUD pamphlets, brochures and other program publications, please call 1-800-767-7468. Some of the publications may be available in Spanish.

For additional information regarding HUD Handbooks, forms and publications, please visit http://www.hud.gov/offices/adm/handbks_forms/handbooks2.cfm.

#25 - The Enterprise Income Verification (EIV) System - June 9, 2006

The Enterprise Income Verification (EIV) System

The Department believes EIV is a critical tool to ensure that the right benefits go to the right persons. EIV is a wage and benefit tool provided through HUD's secure internet system that currently allows public housing agencies (PHAs) and will soon allow Multifamily owners and agents (O/As) to verify tenant-reported income from an independent source during mandatory tenant re-certifications. O/As and PHAs are expected to use the data available through EIV to help the Department reduce errors in subsidy payments.

Current Status

O/As as well as PHAs have been using the Tenant Assessment Subsystem (TASS) to verify tenant Social Security (SS) and Supplemental Security Income (SSI) benefit payments provided by the Social Security Administration (SSA). The first step in transitioning from TASS to EIV took place in March 2006, when the *TASS functionality* was integrated into EIV, meaning the SS/SSI benefit data HUD receives from SSA is now also contained in EIV for verification purposes. Since then, TASS has been operating in parallel with the TASS functionality in EIV. TASS will continue operating in parallel with the TASS functionality in EIV until September 22, 2006; after which TASS will no longer be available, according to the Real Estate Assessment Center (REAC), which administers the TASS system.

Beginning on September 25, 2006, O/As and PHAs will have to obtain SS/SSI benefit verification information only through EIV. It is also intended that, as of September 25, 2006, O/As will join PHAs in being able to obtain through EIV, the Department of Health and Human Services' National Directory of New Hires (NDNH) data such as family new hire information, wage, and unemployment insurance benefit data that comes from State Wage Information Collection Agencies (SWICAs).

Important Dates

March 2006	TASS functionality integrated into EIV.
June 6, 2006	Although after this date no new tenant certification data will be posted in TASS for PHA households, O/As will be able to access June 2006, July 2006, August 2006, September 2006 and October 2006 recertification data for tenants under their portfolio. (PHAs acting as contract administrators also will be able to access tenant data for their assigned projects and contracts.) The tenant data will be refreshed each month until September 22, 2006.
July – Sept 2006	O/As obtain system access rights through the Multifamily Housing (MF) Help Desk for access to EIV.
Sept 22, 2006	According to REAC, access to TASS will be terminated.
Sept 25, 2006	Access to SS/SSI data from SSA through EIV and potentially NDNH data for O/As through EIV.

Instructions for Accessing EIV for O/As

The MF Housing Help Desk will be authorized to provide O/As with system access rights to EIV and will be the primary contact for EIV support. It is anticipated that this process will begin in July 2006. However, until the enhancements to the existing contract for the MF Housing Help Desk are approved, please do not contact the MF Housing Help Desk for EIV support. In addition, please do not contact the EIV Help Desk for EIV support at this time.

A message will be posted to the TRACS, TASS, PIH EIV, and Multifamily Housing Programs RHIP web pages and a notice will be sent through TRACSmial as soon as the Multifamily Housing EIV Help Desk support function is authorized. This message will also include information on when EIV data will be available to O/As and the instructions for gaining access to such data.

More information will follow. Thank you in advance for your patience and cooperation during this transition phase.

#24 – RHIP Tip (Requirement for Residency); Prescription Drug Part D; and Emergency Capital Repair Grants for Multifamily Housing Projects Designated for Occupancy by the Elderly –May 31, 2006

RHIP Tip:

HUD's key requirement for residency is that assisted tenants must have only one residence and receive assistance only in that unit. This rule is meant to ensure that the government pays assistance on only one unit for a family and provides assistance to as many eligible families as possible with available funding.

The sole residence requirement is:

1. A family is eligible for assistance only if the unit will be the family's only residence.
2. The owner must not provide assistance to applicants who will maintain a residence in addition to the HUD-assisted unit.

For additional information regarding the prohibition against double subsidies, please refer to Chapter 3, Paragraph 3-10.C. of *HUD Handbook 4350.3 REV-1 Occupancy Requirements of Subsidized Multifamily Housing Programs*.

ITEMS OF INTEREST:

1. The Department of Health and Human Services recently sent HUD an email with the following information:

CMS released draft 2007 Part D Marketing Guidelines on May 24th for comment. Once final, these guidelines will apply to Medicare Advantage (MA), Medicare Advantage Prescription Drug Plans (MA-PD), Prescription Drug Plans (PDP) and 1876 Cost Plans for the 2007 contract year. Interested parties are invited to submit comments to CMS by no later than 5:00 p.m. EDT, Wednesday May 31, 2006. The draft guidelines include a number of revisions pertaining to existing requirements and policies, as well as new information related to policy or operational decisions adopted since the guidelines were last updated. For example, the 2007 guidelines will reflect the new CMS policy on co-branding announced in the 2007 Call letter (see page 48 of the attached). Beginning in 2007, only non-provider co-branding relationships may be included on member ID cards. Co-branding relationships with providers (i.e., pharmacies) will still be permitted, but may not be designated on member ID cards. As in contract year 2006, plans will be required to submit their member ID cards for review by CMS before distributing to beneficiaries.

2. Emergency Capital Repair Grants for Multifamily Housing Projects Designated for Occupancy by the Elderly.

On May 22, 2006, a notice was published in the Federal Register regarding "Emergency Capital Repair Grants for Multifamily Housing Projects Designated for Occupancy by the Elderly". This notice announces the availability of approximately \$30 million in grant funds to make emergency capital repairs to eligible multifamily projects owned by private nonprofit entities that are designated for occupancy by elderly tenants. The capital repair needs must relate to items that present an immediate threat to the health, multifamily projects owned by private nonprofit entities that are designated for occupancy by elderly tenants. The capital repair needs must relate to items that present an immediate threat to the health, safety, and quality of life of the tenants. The intent of these grants is to provide one-time assistance for emergency items that could not be absorbed within the project's operating budget and other project resources, and where the tenants' continued occupancy in the immediate near future would be jeopardized by a delay in initiating the proposed cure.

The notice which can be found at www.hudclips.org provides instructions for owners of multifamily projects to request funding and instructions for the HUD field offices to process requests. HUD will accept applications on a first-come, first-serve basis upon publication of this notice and will award emergency capital repair grants until available amounts are expended.

Applicants should submit emergency capital repair applications as soon as they have prepared an application that complies with the procedures and requirements contained in this notice.

FOR FURTHER INFORMATION CONTACT: G. DeWayne Kimbrough, Director, Grant and Housing Assistance Field Support Division, Office of Multifamily Housing, Room 6146, Department of Housing and Urban Development, 451 Seventh Street, SW., Washington, DC 20410; telephone (202) 708-3000 (this is not a toll-free number). Persons with hearing or speech impairments may access this number via TTY by calling the toll-free Federal Information Relay Service at (800) 877-8339.

**#23 – RHIIP Tip (Assets); and RHIIP Listserv Suggestions for Items of Interest–
May 24, 2006**

RHIIP Tip:

Did you know that there is no asset limitation for participation in HUD assisted-housing programs? However, when determining annual income, income for eligibility and rent calculation purposes, annual income includes interest, dividends and other net income from family assets.

- Net Family Assets include:
- Cash held in savings and checking accounts, safe deposit boxes, homes, etc. Revocable trusts.
- Equity in rental property or other capital investments.
- Stocks, bonds, Treasury bills, certificates of deposit, mutual funds and money market accounts.
- Individual retirement, 401K, and Keogh accounts.
- Retirement and Pension Funds.
- Cash value of life insurance policies available to the individual before death.
- Personal property held as an investment.
- Lump-sum receipts or one-time receipts, such as, inheritances, capital gains, one-time lottery winnings, victim's restitution, settlements of insurance claims, and any other amounts that are not intended as periodic payments.
- Mortgage or deed of trust held by an applicant or tenant.

Net Family Assets DO NOT include the following and the owner does not compute income from any of these assets:

- Personal property, such as, clothing, furniture, cars, jewelry not held as an investment, vehicles specially equipped for persons with disabilities.
- Interests in Indian trust land.
- Term life insurance policies.
- Equity in the cooperative unit in which the family lives.
- Assets that are part of an active business.
- Assets not effectively owned by the applicant, i.e., assets held in an individual's name, but (a) the asset and any income they earn accrue to the benefit of someone else who is not a member of the family and (b) that other person is responsible for income taxes incurred on income generated by the assets.

For additional information regarding each asset type, please reference Chapter 5, Exhibit 5-2, of *HUD Handbook 4350.3 REV-1 Occupancy Requirements of Subsidized Multifamily Housing Programs*.

ITEMS OF INTEREST:

Many of the topics for the RHIIP Listserv "Items of Interest" come from HUD field office staff and industry partners. If you have information that you would like to share on a national level with other Listserv subscribers, please email Linda_Kornegay@hud.gov, as indicated in our "Introductory RHIIP Listserv" letter currently posted on the RHIIP website at <http://www.hud.gov/utilities/intercept.cfm?/offices/hsg/mfh/rhiip/rhiiplistservavailable.pdf>

Last week, one of HUD's Operations Officers from the Philadelphia Hub shared with us an excellent internet website that he found which contains resourceful information for all of the relevant HUD notices, handbooks, Code of Federal Regulations (CFRs), and so forth, pertaining to the refinancing of affordable housing, such as Section 202 refinancing, Section 236 "decouplings", Mark-to-Market (M2M), etc.). The website address is http://www.recapadvisors.com/learn/ln_learn.asp#sec202.

#22- RHIP Tip (Non-citizen Verification); Section 8 Renewal Policy Guidebook Page Changes; Office of Affordable Housing Preservation (OAHP) and Housing Assistance Payments (HAP) Contract Renewals; and Notice of Funding Availability (NOFA) under the Section 202 Demonstration Pre-Development Grant Program - May 18, 2006

RHIP Tip:

In accordance with Section 214 of the Housing and Community Development Act of 1980, as amended, owners operating projects under certain assisted housing programs are prohibited from making financial assistance available to persons other than United States citizens, nationals, or certain categories of eligible non-citizens. To determine the eligibility status of non-citizens, owners must verify with the Department of Homeland Security (DHS) the citizenship status of each member of a household applying for housing assistance and at interim or annual recertification when there is a change in citizenship or eligible immigration status of any family member. Section 214 is applicable to owners operating projects under the following programs: Section 236, Rent Supplement, Rental Assistance (RAP), and Section 8 including Section 202/8 projects. To verify the validity of the documents owners must:

Obtain computer software to install on the owner's personal computer, an access code and user ID by contacting Mrs. Denise Taylor-Parker at the HUD Headquarters, Office of Multifamily Housing at (202) 708-3000, extension 2892. Mrs. Taylor-Parker will record the required information which will be sent to DHS and request that the computer software and access to the verification system be provided to the owner.

If more than one personal computer is used, it is necessary to request computer software and user IDs for each computer. Multiple users can use a single computer but a unique user ID is needed for each computer user.

Upon receipt of the software, access code and user ID, the owner is able to use the automated system to obtain primary, and in many instances, secondary verification.

If the owner does not have a personal computer or a CD drive and Windows on their personal computer, it will be necessary to verify immigration status using the paper process. A completed Document Verification Request, Form G-845S, and photocopies of the immigration documentation must be mailed to the local immigration office to receive verification of validity of the documents.

Please reference Chapter 3 Paragraph 3-12.H of *HUD Handbook 4350.3 REV-1 Occupancy Requirements of Subsidized Multifamily Housing Programs*. Appendix 2 of this handbook is the instruction manual providing specific and detailed instructions on use of the Systematic Alien Verifications for Entitlements System (SAVE) and interpretation of results of DHS verification information.

ITEMS OF INTEREST:

1. The Office of Multifamily Housing has issued several page changes to the project-based Section 8 Renewal Policy Guidebook that pertain to the Housing Assistance Payment (HAP) contract. The copies of the changes will be available on HUDCLIPs at www.hudclips.org. The major changes to the Guidebook are as follows:

a. Removes previous guidance, found at Sections 2-1E, 4-1 and 6-1B that stated once the owner of an exception project renewed under either Option One or Option Two they were prohibited from reverting back to an exception status. The Office of General Counsel (OGC) reexamined this policy and found that the Multifamily Assisted Housing Reform Act ("MAHRA") did not support this position. A clarification to the MAHRA regulations was published January 12, 2006. Therefore, at any renewal the owner of an exception project may elect to renew under any option that the contract is eligible for at the time of renewal.

b. Authorizes Program Centers to approve Discretionary Mark-Up-To-Market requests without first obtaining Headquarters approval.

c. MAHRA originally limited the renewal of Section 8 contracts associated with preservation projects to a term of one year. MAHRA was amended and the one-year limitation was removed. Therefore, preservation projects are now permitted to use multiyear Section 8 contracts. The maximum term of the multiyear contract will be based on the lesser of 20 years or the remaining term of the Use Agreement.

d. MAHRA limits the owner of a preservation project to renew his/her Section 8 contract using Option Five. We have emphasized this requirement.

2. The Office of Affordable Housing Preservation (OAHP) sent out an email on May 4th with the information shown below pertaining to Housing Assistance Payments (HAP) contract renewals. Please visit the OAHP's Section 8 internet website at <http://www.hud.gov/offices/hsg/omhar/readingrm/sect8.cfm> for additional information about OAHP.

Out Year Contracts:

Now that the new Owner Election Form has been approved for use (attached) OAHP can again accept properties in for restructuring with HAP contracts that may have an expiration several years in the future ("Out Year Contracts"), without the owner having to give up their current, above-market contract. While OAHP has done many of these transactions over the years, the approaching sunset of Mark-to-Market (M2M) authorities, and the need for a Section 514 contract as evidence of a "binding commitment" had required OAHP to restrict Out Year projects. With the release of the new Owner Election Form, however, OAHP can again accept these referrals.

There is a cost to OAHP for completing a restructuring plan. OAHP has set up the following guidelines for Out Year referrals (use of the Contract Renewal Form for Out Year Contracts when a new Section 514 contract will not be put in place):

Contract Expiration must be in excess of 18 months from owner request to enter the program or the Multifamily referring office must indicate that funding is not available for issuance of a Section 514 contract at this time.

A rationale for a potential OAHP restructuring must be submitted with the request. Possible reasons may include:

- Need for significant rehab

- Insufficient cash flow to meet current operating/cash flow needs

OAHP has in its toolbox the ability to use an Out Year Rider, which will allow the current contract to remain in place, with the higher contract rents, until maturity. The rent differential in many cases flows to the property's replacement reserves. The net effect of this Rider is to create a smaller Mortgage Restructuring note, saving the owner money long term. The Rider will only be used in the following situations:

The out year contract must mature between 6 months and 36 months past the closing of the M2M restructuring. If outside of this window, the owner will have to accept a M2M Full restructuring contract at market rents, beginning the month after the M2M closing.

The gross difference between market rents and contract rents must exceed \$25,000 per year.

The Out Year Rider recapture agreement is administered by the respective Multifamily office. Therefore, the MF office must agree to monitor the recovery of the out year monies (difference between contract and market) and implement the M2M Full restructuring contract at market rents determined by OAHP, increased by OCAF since the date of closing.

Even when an Out Year Rider is not used, an OAHP Restructuring may benefit the property and preserve affordable housing. HUD will have a Use Agreement in place, the property will be rehabbed as necessary and OAHP will ensure that cash flow is sufficient to maintain the property long term. Please contact Norman Dailey if you have any questions about this process. (Norman_Dailey@hud.gov or at 202-708-0614, x8371)

Bond Financed Properties Renewed Under Option 4:

OAHP is in the process of pulling an updated report from REMS of all properties that were renewed under Option 4 and comparing that information to their Bond Database. The Renewal Guide Chapter 6 (on Option 4) requires that the bond documents (for Programs eligible for M2M; i.e. not 202, 811, etc) be reviewed by OAHP to determine whether the properties are exempt or not. OAHP will distribute the database in the very near future and ask for Multifamily HUD staff assistance in clearing any exceptions to the Guide. With Sunset less than 6 months away, it is important that any M2M eligible properties are identified, the owners notified, and referral is completed as soon as possible.

OAHP has also recently been notifying some of the Field offices and owners of properties which were previously exempt. Exemptions due to a bond indenture lockout or prepayment restriction in the mortgage will no longer be exempt when the lockout expires.

3. Notice of Funding Availability (NOFA) under the Section 202 Demonstration Pre-Development Grant Program

The NOFA announcing funding under the Section 202 Demonstration Pre-Development Grant Program was published in the Federal Register on Thursday, May 4, 2006. The NOFA makes available approximately \$42,178,662 for pre-development grants to Sponsors who received fund reservations under the Fiscal Year 2005 Section 202 Supportive Housing for the Elderly Program.

The Section 202 Demonstration Pre-Development Grant Program is to assist Sponsors/Owners to bring their projects to initial closing within 18 months of their Section 202 fund reservation. The funds are awarded for such pre-development activities as: architectural and engineering work, site control extensions, and other planning related expenses that are eligible for funding under the Section 202 Supportive Housing for the Elderly Program.

Applicants will be required to submit their application via www.grants.gov no later than the deadline date of June 6, 2006. To view the notice in its entirety, please visit www.grants.gov.

#21- RHIP Tip (Interim Recertifications); and Frequently Asked Questions Regarding the revised form HUD-9834, Management Review - May 11, 2006

RHIP Tip:

When processing an interim recertification, the owner must ask the tenant to identify all changes in income, expenses, or family composition since the last recertification. Owners need only verify those items that have changed.

Reference Chapter 5 Paragraph 5-22 of *HUD Handbook 4350.3 REV-1 Occupancy Requirements of Subsidized Multifamily Housing Programs*. Additional information about the procedures for conducting interim recertifications is discussed in Chapter 7, Section 2.

ITEMS OF INTEREST:

Frequently Asked Questions (FAQs) regarding the revised form HUD-9834, Management Review for Multifamily Housing Projects (MOR), were first published March 10, 2006. Since that time additional questions and responses have been added. The complete, revised document containing MOR FAQs has been posted on the following websites:

- Contract Administration site <http://www.hud.gov/offices/hsg/mfh/rfp/sec8rfp.cfm>, under Frequently Asked Questions
- Multifamily Housing site <http://www.hud.gov/offices/hsg/hsgmulti.cfm>, under WHAT'S NEW.

In addition, on May 5th HUD staff and Performance-Based Contract Administrators (PBCAs) were advised of the following information by the Office of Multifamily Housing Asset Management in Washington DC:

Based on HUD field office comments, FHEO and Multifamily Housing (MFH) Headquarters staff have renegotiated Part D form HUD- 9834, "Documents Reviewer Should Obtain From Owner/Agent" of the civil rights front-end and limited monitoring review protocol.

The modification to Part D will state that MFH staff and CAs will only bring back (from their MOR) documents listed in Part D of the checklist if requested by FHEO. As with all requests for documents, FHEO may only send these requests to MFH on an annual basis. MFH will then provide the applicable FHEO information request to the CA. MFH and the CAs will honor the requests for the next on-site review for which they have not yet sent a letter informing the owner/agent of the date of the forthcoming review nor requested any documents. If a property has already been reviewed, the FHEO documentation request for that project will be included in the next MOR.

This new procedure is effective immediately. At this time, FHEO may send a revised annual request to the MFH staff requesting documents to bring back for any and/or all projects. FHEO may also advise MFH staff that there are no requests to bring back any documents for their next review for any projects. If FHEO does not send a request to MFH, the original Protocol will remain in effect until July 1; that is, all on-site visits will include collection of the entire list of documents. After July 1, 2006, no documents will be collected unless specifically requested by FHEO.

With the closing of the MOR Mailbox as of May 1st, please send questions and concerns regarding the form HUD-9834 to the appropriate HUD Desk Officer for HUD staff or Contract Administration Oversight Monitor (CAOM) for PBCAs.

#20 – RHIIP Tip (Estimating Anticipated Income); RHIIP Training Calendar; and Medicare Prescription Drug Benefit - May 4, 2006

RHIIP Tip:

Some circumstances present more than the usual challenges to estimating anticipated income. Examples of challenging situations include a family that has sporadic work or seasonal income or a tenant who is self-employed. In all instances, owners are expected to make a reasonable judgment as to the most reliable approach to estimating what the tenant will receive during the year. In many of these challenging situations, midyear or interim re-certifications may be required to reflect changing circumstances.

For examples of approaches to more complex situations, please see Chapter 5 Paragraph **5-5C** of *HUD Handbook 4350.3 REV-1 Occupancy Requirements of Subsidized Multifamily Housing Programs*.

ITEMS OF INTEREST:

1. Did you know that on the RHIIP website is a RHIIP Training and Seminar Calendar of Events located at <http://www.hud.gov/offices/hsg/mfh/rhiip/eventscalendar.cfm>. We encourage those who are interested to review the calendar and to contact Elena_N._Herl@hud.gov if they have occupancy-related training they would like included in the RHIIP Calendar of Events.
2. The Department of Health and Human Services sent HUD an email on May 3rd with the following information regarding Contingency Planning for the May 15, 2006 Part D Initial Enrollment Period Deadline (Medicare Prescription Drug Benefit):

On May 2nd, the Centers for Medicare & Medicaid Services (CMS) issued a memorandum to Part D plan sponsors on contingency planning for the May 15, 2006 Initial Enrollment Period (IEP) deadline. CMS is reaching out to its plan partners to ensure that they are prepared to deal with anticipated increases in enrollment volume and that new enrollees will be able to obtain prescription medications on June 1, 2006.

CMS is continuing to stress to beneficiaries and partner organizations the importance of enrolling in Part D as soon as possible. We also are taking a number of steps to deal with the likelihood of a last-minute surge in enrollment, such as operating additional 1-800-MEDICARE call center sites and having call center staff work through 3:00 a.m. EDT on May 16 to accept enrollments.

CMS has instructed plan sponsors to make similar preparations for responding to enrollments between now and May 15, as detailed in the attached memo. Plans must have procedures in place to accept mailed applications postmarked on or before May 15, 2006. Incomplete applications received by May 15 will be treated as complete for purposes of meeting the IEP deadline.

In addition, HUD Secretary Jackson sent an email on May 1st to HUD employees reminding them about the importance of the May 15th deadline. He invited all HUD employees to contact their families and friends who qualify for Medicare to find out if they have made a decision about enrolling in a Medicare prescription drug plan. The Secretary stressed the fact that HUD employees can make a difference in the lives of seniors and Medicare beneficiaries around the country by helping them save money on life-saving prescription drugs and giving seniors the peace of mind of knowing that their savings will not be wiped out because of prescription drugs.

#19 – RHIP Tip (Frequent Calculation Errors) - May 1, 2006

RHIP Tip:

The most frequent errors encountered in reviews of annual and adjusted income determinations in tenant files fall in three categories:

1. Applicants and tenants failing to fully disclose income information;
2. Errors in identifying required income exclusions; and
3. Incorrect calculations of deductions often resulting from failure to obtain third party verification.

Careful interviewing and thorough verification can minimize the occurrence of these errors.

For further information and examples, please refer to Chapter 5 Paragraph **5-1C** of *HUD Handbook 4350.3 REV-1 Occupancy Requirements of Subsidized Multifamily Housing Programs*.

ITEMS OF INTEREST:

The Department of Health and Human Services sent HUD an email on April 20th with the following information regarding "Standardized Codes and Exceptions Form for Medicare Prescription Drug Benefit":

The Centers for Medicare and Medicaid Services (CMS) in collaboration with their partners has been working to simplify administrative processes and create common procedures throughout the Medicare Part D program. To that end, America's Health Insurance Plans (AHIP), the National Association of Chain Drug Stores (NACDS), and the National Community Pharmacists Association (NCPA) met with CMS Administrator Mark B. McClellan, MD, PhD, to announce standardized coding messaging designed to assist pharmacists and better serve beneficiaries when they fill prescriptions at pharmacies.

Specifically, these standardized electronic messages will help pharmacists quickly determine the appropriate course of action for filling beneficiaries' prescriptions under four different circumstances: (1) when a particular drug is not covered; (2) when prior authorization is required; (3) when plan quantity or other coverage limitations have been exceeded; and (4) when the pharmacy is not part of the Part D plan's network. These organizations' agreement on this messaging will result in the consistent use of key terms by Part D plans and thus allow pharmacists to more quickly address issues at the pharmacy counter.

In addition, Dr. McClellan announced the formation of the Pharmacy Quality Alliance (PQA). PQA will aim to improve pharmacy care and outcomes through a collaboration of the pharmacy community, health plans, government, employers, physicians, and consumers. The goal of PQA will be to agree on a strategy for measuring and reporting data that will help consumers make informed choices and appropriate healthcare decisions.

"Pharmacists and pharmacies have demonstrated how important they are to the implementation of the Medicare drug benefit, and we're pleased to support these collaborative efforts," said Dr. McClellan. "The PQA is an important next step in supporting pharmacists' efforts to improve quality and reduce costs in our health care system," he said.

To further the goal of simplifying procedures in the new drug benefit, last week the American Medical Association (AMA) and America's Health Insurance Plans (AHIP), in conjunction with CMS, released a standardized exceptions form designed to assist physicians in applying for exceptions and prior authorizations on behalf of Medicare beneficiaries enrolled in Medicare drug

plans. This form allows for a simplified process for physicians to apply for coverage determinations on behalf of all of their Medicare patients, regardless of which Part D plan the beneficiary is enrolled in.

The letter and accompanying attachment on standardized coding as well as the cover note and standardized coverage determination form are attached.

#18 – RHIP Tip (Income From Assets); Changes Coming Soon for the Active Partner Performance System (APPS) Electronic Filing Requirements; Reasonable and Necessary Project Operating Account Expenses Related to Front-Line Management Activities; and Prescription Drug Coverage– April 24, 2006

RHIP Tip:

Did you know that when net family assets are more than \$5,000, annual income includes the greater of the following:

- a) Actual income from assets; or
- b) A percentage of the value of family assets based upon the current passbook savings rate as established by HUD. This is called imputed income from assets. The passbook rate is currently set at 2%.

For further information and examples, please refer to Paragraph 5-7F of *HUD Handbook 4350.3 REV-1 Occupancy Requirements of Subsidized Multifamily Housing Programs*.

ITEMS OF INTEREST:

1. Changes Coming Soon for the Active Partner Performance System (APPS) Electronic Filing Requirements:

Effective on July 1, 2006, all participants required to apply for previous participation clearance must do so through the Active Partner Performance System (APPS). A memorandum was signed by the Commissioner on April 21, 2006, regarding the implementation date and includes background information and regulatory requirements for APPS.

2. Reasonable and Necessary Project Operating Account Expenses Related to Front-Line Management Activities:

The HUD Director of the Office of Asset Management in Washington, D.C. issued a memorandum dated April 4, 2006, to all HUD Multifamily Hub, Program Center and Operations Directors regarding expenses deemed "reasonable and necessary" that can be paid from the project operating account.

3. The Department of Health and Human Services recently sent HUD an email with the following information:

On April 20, 2006, HHS announced that over 30 million people with Medicare now have prescription drug coverage. This brings the total of those who have signed up individually for Medicare prescription drug coverage since enrollment began on November 15, 2005 to over 8 million.

In addition, 5.8 million people with Medicare are getting drug coverage through the Veterans Administration and other sources of coverage that are at least as good as Medicare -- bringing the total to approximately 35.8 million Medicare beneficiaries who are now receiving prescription drug coverage.

HHS Secretary Mike Leavitt said "These strong enrollment numbers are a tribute to everyone in the national network of caring -- all of our partners, community leaders, the State Health Insurance Programs (SHIPS), and family members, who have provided counseling and assistance to the millions of beneficiaries who are now taking advantage of this new benefit and saving money."

"The May 15th deadline is fast approaching. We urge everyone who has not signed up to act now to avoid a last minute rush," said CMS Administrator Mark B. McClellan, M.D., Ph.D. "There are plenty of ways to get help. Call 1-800-MEDICARE or attend one of the many thousands of events we are conducting with our partners across the country before the May 15th deadline. Sign up now and start saving on your drugs. And if you don't need drugs now, by signing up you can get the lowest cost protection for the future."

Overall prescription drug coverage figures as of April 18 are:

Stand-Alone Prescription Drug Plans: More than 8 million people with Medicare have enrolled in stand-alone prescription drug plans.

- 1. Medicare Advantage with Prescription Drugs:** About 5.8 million received coverage through Medicare Advantage plans with drug coverage (MA-PDs). More than 950,000 of these beneficiaries signed up on their own.
- 2. Medicare/Medicaid:** About 5.8 million were automatically enrolled in prescription drug plans, plus about 500,000 enrolled in Medicare Advantage plans with prescription drug coverage.
- 3. Retiree Coverage:** More than 6.8 million retirees are enrolled in the Medicare retiree subsidy. In addition, about 1.4 million retirees are in employer and union-sponsored coverage that incorporates Medicare group drug coverage.
- 4. Federal retiree coverage:** 3.5 million

TRICARE: There are 1.9 million beneficiaries with TRICARE retiree coverage.

FEHB: There are 1.6 million beneficiaries with FEHB retiree coverage. This figure now accounts for spouses with Medicare who are covered under a FEHB family policy by retirees who also have Medicare coverage.

5. Additional Sources of Prescription Drug Coverage for Medicare Beneficiaries: Approximately 5.8 million Medicare beneficiaries have alternative sources of "creditable" prescription drug coverage:

Veterans Affairs (VA): There are an estimated 3.2 million beneficiaries with creditable drug coverage through the VA.

Indian Health Service (IHS): There are an estimated 0.1 million beneficiaries with creditable drug coverage through the IHS.

Active Workers with Medicare Secondary Payer: There are an estimated 2.0 million beneficiaries who are active workers with creditable drug coverage through an employer group health plan.

Other Retiree Coverage: An estimated 500,000 retirees are continuing in coverage from a former employer that is not coordinated with Medicare drug coverage.

To view enrollment data online visit,
http://www.cms.hhs.gov/PrescriptionDrugCovGenIn/02_EnrollmentData.asp

Those wishing to enroll in Medicare Part D, visit www.medicare.gov.

#17 – RHIP Tip (Child Care Deductions); and Questions & Answers Regarding Eligibility of Students for Section 8 Assisted Housing (Supplementary Guidance) - April 19, 2006

RHIP Tip:

Did you know that a childcare deduction is one of five possible deductions that may be subtracted from annual income based on allowable family expenses and family characteristics? If a childcare deduction is taken, the amount will be subtracted from annual income to arrive at the adjusted income. Adjusted income is generally the amount upon which tenant rent is based.

FACTS ON CHILD CARE DEDUCTIONS:

1. Anticipated expenses for the care of children under age 13 (including foster children) may be deducted from annual income if all of the following are true:
 - a) The care is necessary to enable a family member to work, seek employment, or further his/her education (academic or vocational).
 - b) The family has determined there is no adult family member capable of providing care during the hours care is needed.
 - c) The expenses are not paid to a family member living in the unit.
 - d) The amount deducted reflects reasonable charges for child care.
 - e) The expense is not reimbursed by an agency or individual outside the family.
 - f) Childcare expenses incurred to permit a family member to work must not exceed the amount earned by the family member made available to work during the hours for which child care is paid.
2. When childcare enables a family member to work or go to school, the rule limiting the deduction to the amount earned by the family member made available to work applies only to child care expenses incurred while the individual is at work. The expense for childcare while that family member is at school or looking for work is not limited.
3. Childcare attributable to the work of a full-time student (except for head, spouse, co-head) is limited to not more than \$480, since the employment income of full-time students in excess of \$480 is not counted in the annual income calculation. Childcare payments on behalf of a minor who is not living in the applicant's household cannot be deducted.
4. Childcare expenses incurred by two assisted household with split custody can be split between the two households when the custody and expense is documented for each household and the documentation demonstrates that the total expense claimed by the two households does not exceed the cost for the actual time the child spends in care.

For further information and examples, please refer to Section 5-10B of *HUD Handbook 4350.3 REV-1 Occupancy Requirements of Subsidized Multifamily Housing Programs*.

ITEMS OF INTEREST:

QUESTIONS & ANSWERS REGARDING ELIGIBILITY OF STUDENTS FOR SECTION 8 ASSISTED HOUSING – SUPPLEMENTARY GUIDANCE

On April 12, 2006, a conference call was held with HUD Headquarters staff and the HUD RHIP Help Desk Representatives to discuss the implementation of the new Section 8 eligibility

restrictions of students for Section 8 assisted housing. Questions and answers from the conference call have been posted to the <http://www.hud.gov/offices/hsg/mfh/rhiip/mfhrhiip.cfm>. Please contact your RHIP Representative if you have further questions and concerns regarding the final notice.

As indicated in Listserv posting #17, the final notice regarding the eligibility of students for Section 8 assisted housing was posted in the Federal Register on April 10, 2006. This notice provides additional guidance to assist public housing agencies and multifamily project owners and management agents with the implementation of the new Section 8 eligibility restrictions for the final rule that was published in the Federal Register on December 30, 2005 and became effective on January 30, 2006. The new student eligibility restrictions only apply to HUD's Section 8 programs administered by the Office of Housing and the Office of Public and Indian Housing. This rule and notice do not apply to HUD's Public Housing program.

#16 – Eligibility of Students for Section 8 Assisted Housing – Supplementary Guidance; and Corrections to Posting #13 – April 7, 2006

ITEMS OF INTEREST:

1. ELIGIBILITY OF STUDENTS FOR SECTION 8 ASSISTED HOUSING – SUPPLEMENTARY GUIDANCE

The attached notice will be posted in the Federal Register on April 10, 2006. This notice provides additional guidance to assist public housing agencies and multifamily project owners and management agents with the implementation of the new Section 8 eligibility restrictions for the final rule that was published in the Federal Register on December 30, 2005 and became effective on January 30, 2006. The new student eligibility restrictions only apply to HUD's Section 8 programs administered by the Office of Housing and the Office of Public and Indian Housing. This rule and notice do not apply to HUD's Public Housing program.

BACKGROUND: As you may recall, on December 30, 2005, HUD published a final rule implementing a new law that restricts individuals who are (1) enrolled at an institution of higher education (i.e., students), under the age of 24, not a veteran, unmarried, and do not have a dependent child, and (2) seeking assistance under section 8 of the United States Housing Act of 1937 (section 8 assistance) in their individual capacity (that is, separately from their parents) from receiving section 8 assistance if neither the student nor the student's parents are income eligible. The final rule is posted at www.hudclips.org under FR-5036-F-01, dated December 30, 2005, titled "Eligibility of Students for Assisted Housing Under Section 8 of the U.S. Housing".

2. CORRECTION TO POSTING #13:

In Listserv Posting #13 dated March 24, 2006, topic "Tenant Assessment Subsystem (TASS) Incorporated into Enterprise Income Verification (EIV) System", it was indicated that EIV will become mandatory in September 2006. Although it is expected that EIV will eventually become mandatory, it will not be in September 2006.

#15 – RHIP Tip (Regular Cash Contributions); and Management and Occupancy (MOR) Questions & Answers- April 4, 2006

RHIP Tip:

1. Owners must count as income any regular contributions and gifts from persons not living in the unit. These sources may include rent and utility payments paid on behalf of the family, and other cash or non-cash contributions provided on a regular basis.
2. Groceries and/or contributions paid directly to the childcare provider by persons not living in the unit are excluded from annual income.
3. Temporary, nonrecurring, or sporadic income (including gifts) is not counted.

For further information, please refer to Section 5-6F of *HUD Handbook 4350.3 REV-1 Occupancy Requirements of Subsidized Multifamily Housing Programs*.

ITEM OF INTEREST:

MANAGEMENT AND OCCUPANCY (MOR) - QUESTIONS AND ANSWERS:

Frequently Asked Questions (FAQs) regarding the revised form HUD-9834, Management Review for Multifamily Housing Projects (MOR), are posted on the following websites:

- Contract Administration site <http://www.hud.gov/offices/hsg/mfh/rfp/sec8rfp.cfm>, under Frequently Asked Questions - Multifamily Housing site
- <http://www.hud.gov/offices/hsg/hsgmulti.cfm>, under WHAT'S NEW.

The MOR form, HUD-9834, is completed by HUD staff, Performance-Based Contract Administrators/Contract Administrators and Mortgagees of Coinsured Projects (Mortgagees) to assess the management and oversight of multifamily housing projects. To view the MOR form, go to <http://www.hudclips.org>. To assist with implementation of the MOR form, a mailbox was established to address any questions related to the revised HUD-9834 and provide technical guidance. The FAQs were developed from questions submitted to the mailbox and are categorized following the order of the HUD-9834. For example, all FAQs pertaining to Part E – Leasing and Occupancy are grouped together. Additional FAQs will be added as necessary and will be added to the bottom of the applicable section. The FAQ document will reflect when it has been updated, i.e. "Updated on _____".

Please send questions regarding the HUD-9834 to **Hq_Mf_Mor/HSNG/HHQ/HUD@HUD.gov**.

#14- RHIP Tip (Asset Disposed For Less Than Fair Market Value); Medicare Prescription Drug Benefit; and Federal Register Seeking Public Comment regarding Eviction for Drug Abuse and Other Criminal Activity - March 27, 2006

RHIP Tip:

Applicants and tenants must declare whether an asset has been disposed of for less than fair market value at each certification and recertification. Owners must count assets disposed of for less than fair market value during the two years preceding certification or recertification. The amount counted as an asset is the difference between the cash value and amount actually received. This provision does not apply to families receiving only BMIR assistance (Below Market Interest Rate).

Any asset that is disposed of for less than its full value is counted, including cash gifts as well as property. To determine the amount that has been given away, owners must compare the cash value of the asset to any amount received in compensation. However, the rule applies only when the fair market value of all assets given away during the past two years exceeds the gross amount received by more than \$1,000.

When the two-year period expires, the income assigned to the disposed asset also expires. If the two-year period ends in the middle of a recertification year, then the tenant may request an interim recertification to remove the disposed asset(s).

For further information including examples, please refer to Section 5-7G6 of *HUD Handbook 4350.3 REV-1 Occupancy Requirements of Subsidized Multifamily Housing Programs*.

ITEMS OF INTEREST:

1. The Department of Health and Human Services recently sent HUD an email with the following information:

On Monday, March 20, 2006, under the Medicare prescription drug benefit, there is extra help available to beneficiaries with limited incomes and resources. This extra help provides comprehensive coverage with no or low premiums and low or no deductible. To ensure that beneficiaries receive the benefit of the extra help, CMS (Centers for Medicare and Medicaid Services) is facilitating the enrollment of certain beneficiaries into prescription drug plans. This week, CMS will begin mailing letters to approximately 1.2 million people who are enrolled in other federal assistance programs such as Supplemental Security Income (SSI) and Medicare Savings Programs, as well as beneficiaries who have applied for and been approved for the extra help.

The letters let the beneficiary know in which Medicare prescription drug plan they will be enrolled by CMS if they take no action before April 30. Unless they enroll on their own during March, these beneficiaries will have their prescription drug coverage begin on May 1. CMS is enrolling these beneficiaries earlier to make sure that they receive the benefit of the extra help immediately, and without having to pay a penalty. These beneficiaries can still decline the enrollment before it becomes effective.

All of the plans that qualify for the automatic enrollment must meet Medicare's standards for access to medically necessary drugs at a convenient local pharmacy. Beneficiaries also have the option to change plans if they are unhappy with the plan into which CMS facilitated them. The letters make it clear to beneficiaries that they can choose a different approved plan in their area. The facilitated enrollment letter will list all the prescription drug plans available in their region with premiums at or below the low-income premium subsidy amount. It also recommends calling 1-800-MEDICARE to find out more about these plans.

Fact sheets with more information about facilitated enrollment and copies of the facilitated enrollment letters will be available on-line at <http://www.cms.hhs.gov/apps/media/press/release.asp?Counter=1806>. The letters will be posted on the CMS web site soon.

2. Federal Register Seeking Public Comment regarding Eviction for Drug Abuse and Other Criminal Activity

Federal Register Document Number: FR-5044-N-02 Date: January 24, 2006

The proposed information collection requirement described below has been submitted to the Office of Management and Budget (OMB) for review, as required by the Paperwork Reduction Act. The Department is soliciting public comments on the subject proposal.

The collection of information implements the statute and gives Public Housing Agencies (PHAs) and assisted housing owners the tools for adopting and implementing fair, effective and comprehensive policies for screening out program applicants who engage in illegal drug use or other criminal activity and for evicting or terminating assistance of persons who engage in such activity. PHAs that administer a Section 8 or public housing program under an Annual Contributions Contract (ACC) with HUD may request criminal history records from any law enforcement agency concerning an adult member of a household applying for admission to a public housing or Section 8 program. Members of affected public: State or Local Government; PHAs.

Interested persons are invited to submit comments regarding this proposal. Comments should refer to the proposal by name/or OMB Control number and should be sent to: Aneita Waites, Reports Liaison Officer, Public and Indian Housing, Department of Housing and Urban Development, 451 7th Street, SW., Room 4116, Washington, DC 20410-5000.

Comments Due: **March 27, 2006.**

The Federal Register documents can be viewed at <http://www.hudclips.org/cgi/index.cgi>

#13 – Tenant Assessment Subsystem (TASS) Incorporated into EIV; Mark to Market Revisions (Proposed Rule); Federal Register Postings on the Renewal of Expiring Section 8 Project-Based Assistance Contracts; Final FY 2006 Fair Market Rent (FMR) Documentation System; and Publications for Revised Contract Renewal Request Form (Multifamily Section 8 Contracts) & form HUD-9624 – March 24, 2006

ITEMS OF INTEREST:

1. Tenant Assessment Subsystem (TASS) Incorporated into Enterprise Income Verification (EIV) System

The Office of Public and Indian Housing's Real Estate Assessment Center's March 10, 2006 release of the EIV System incorporated the functionality of the TASS. The TASS is used by private owners, management agents and contract administrators to perform upfront income verification by obtaining Social Security/Supplemental Security Income (SS/SSI) benefit information and benefit history reports.

The TASS functionality in EIV will remain virtually the same. To give Multifamily Housing users an opportunity to become acclimated to EIV, which will become mandatory in September 2006, TASS will continue to operate until that time. However, Multifamily Housing users are encouraged to begin using the EIV system now. The Multifamily Housing EIV User Administration Manual, which provides instructions on the use of EIV, and the EIV Multifamily Housing User Agreement and Rules of Behavior may be found on Housing's RHIP website at <http://www.hud.gov/offices/hsg/mfh/rhiip/helpdesk.pdf> under "What's New?".

In addition, the EIV system also includes the Department of Health and Human Services (HHS) National Directory of New Hires (NDNH) data. While this information is not currently available for Multifamily Housing users, HUD is currently working with HHS to allow Multifamily Housing users access to the data to use for upfront verification purposes. The NDNH data consists of employment and income information reported to states by employers and submitted to the NDNH.

2. Implementation of Mark-to-Market Program Revisions; Proposed Rule

The Office of Affordable Housing Preservation (OAHP), formerly the Office of Multifamily Housing Assistance Restructuring (OMHAR) recently issued the following announcement:

On March 14, 2006 proposed revisions to the Mark-to-Market program regulations were published in the Federal Register. The rule invites interested persons to comment, with comments due back to the Regulations Division by May 15, 2006. The Federal Register document can be viewed at <http://www.hudclips.org/cgi/index.cgi>.

Although the proposed rule makes a number of changes to the Mark-to-Market program regulations, a vast majority of these changes have been operational since enactment of the Mark-to-Market Extension Act of 2001.

To provide some background on the proposed regulations, the Office of Affordable Housing Preservation (OAHP) will conduct a conference call on Monday, March 27 at 3:00pm EST. During this call, an overview of the proposed rule will be provided, including a discussion of the changes, why the changes were needed and the effect. The call-in information and additional details will be distributed by March 23, 2006.

Due to the anticipated size of the audience, direct questions will not be taken during the call. Anyone with specific questions before the call should send them to Norman_Dailey@hud.gov or resourcedesk@oahp.net. In addition, during the call the e-mails to Norman_Dailey@hud.gov will be monitored. If there are several questions on a topic that can be easily answered, a response will be provided before the end of the call. Otherwise by April 5, 2006, answers to non-property specific questions will be posted and distributed via the OAHP Resource Desk (www.OAHP.net)

3. Federal Register Postings on the Renewal of Expiring Section 8 Project-Based Assistance Contracts

A final rule was published in the January 12, 2006 Federal Register (FR-4551-F-01) that governs renewal of Section 8 project-based assistance contracts, except renewal as part of a restructuring plan (Restructuring Plan) in the Mark-to-Market program. Currently, contracts are being renewed under the authority of an interim rule that became effective October 11, 1998, and later statutory changes. This final rule was effective February 13, 2006. To final rule can be view at www.hudclips.org.

In addition, two Federal Register proposed rules were issued on January 12, 2006, for public comments that were due by March 13, 2006. The proposed rules would revise current HUD regulations that govern the renewal of expiring Section 8 project-based assistance contracts. Specifically, the proposed rules would amend the regulations to include tenant protections in the case of a contract that is not renewed, and establish rent levels when an expiring contract is renewed. Certain other changes to these regulations are being made by the final rule noted above (FR-4551-F-01). The proposed rules (FR4551-P-02 and HUD-2006-001) can be viewed on www.hudclips.org.

4. Final FY 2006 Fair Market Rent (FMR) Documentation System

Changes may have occurred to FMR areas and designations of Metropolitan Sampling Areas (MSAs). To further understand this process, a FMR Documentation system is available. This system provides complete documentation of the development of the final FY 2006 FMRs for any area of the country selected by the user. After selecting the desired geography, the user is provided a page containing a summary of how the final FY 2006 FMRs were developed and updated. The updates start with the formation of the final FY 2006 FMR Areas from the metropolitan Core-Based Statistical Areas (CBSAs) as established by the Office of Management and Budget, the 2000 Census benchmark, incorporating information from Revised Final FY 2005 FMRs, and updates to FY 2006 including information from local Random Digit Dialing (RDD) survey data. The tables on the summary page include links to complete detail on how the data were developed. To access the FMR documentation system, please visit <http://www.huduser.org/datasets/fmr/fmrs/index.asp?data=fmr06>

PUBLICATIONS:

Revised Contract Renewal Request Form – Multifamily Section 8 Contracts, form HUD-9624

The **revised** Contract Renewal Request Form HUD-9624, is posted at www.hudclips.org. Multifamily Project-Based Section 8 property owners must submit the completed form within specified timeframes to the jurisdictional HUD Office or Contract Administrator who has administration responsibilities for the owners' Section 8 Housing Assistance Payment (HAP) contract. For additional information pertaining to the Section 8 HAP contract renewal process and how to complete the form, please visit <http://www.hud.gov/offices/hsg/mfh/mfhsec8.cfm>.

#12 – RHIP Tip (Income of Dependents); TRACS Compliance Percentage Increase Forthcoming; RHIP Listserv Subscriber Info; and Thank You to Industry Partners - March 16, 2006

RHIP Tip:

A dependent is a family member who is under 18 years of age, is disabled, or is a full-time student. The head of the family, spouse, co-head, foster child, or live-in aide are never dependents. Some income received on behalf of family dependents is counted and some is not.

- Earned income of minors (family members under 18) **is not** counted.
- Benefits or other unearned income of minors **is** counted.

For additional information about calculating income of dependents, please refer to Chapter 5, paragraph 5-6. A.3 of HUD Handbook 4350.3 REV1, Occupancy Requirements of Subsidized Multifamily Housing Programs:

ITEMS OF INTEREST:

1. TRACS Compliance Percentage Increase is Forthcoming

By law, owners and agents of certain subsidized multifamily projects are required to submit Housing Assistance Payment (HAP) vouchers containing tenant certifications, re-certifications and subsidy billings to HUD electronically through the HUD Tenant Rental Assistance Certification system (TRACS). The tenant data that owners/agents submit electronically through the TRACS must be correct in order for HUD payments to be made. HUD has established a goal for the TRACS Tenant Compliance Percentage Standard at 100%.

On February 14, 2006, a TRACS announcement was posted regarding the TRACS Tenant Compliance Percentage Standard increase. Currently the TRACS compliance percentage is at 85%; however this compliance percentage will be raised to 90%, effective April 1, 2006. The new increase will affect any HAP voucher submitted on or after April 1, 2006. Any questions regarding the new 90% Standard should be directed to the Multifamily Help Desk at 1-800-767-7588.

To view the TRACS announcements, please visit
<http://www.hud.gov/offices/hsg/mfh/trx/announcements.pdf>

2. RHIP Listserv Archive

The archive of the most recent ten Listserv postings will be available on the Multifamily RHIP webpage at: <http://www.hud.gov/offices/hsg/mfh/rhiip/mfhrhiip.cfm>

3. Special Thank You

The Department would like to thank those industry partners who have been promoting the new HUD RHIP Listserv by publishing articles in their newsletters and other informational documents about the Listserv that are shared with their owners/agents and other housing partners. With the assistance of HUD's industry partners in spreading the word about the Listserv and encouraging people to sign up, the number of subscribers is growing rapidly to over 850 at this time.

#11 - FY 2006 Income Limits; and FY 2006 Fair Market Rents - March 9, 2006

PUBLICATIONS:

FY 2006 Income Limits and Fair Market Rents

You can view the approved final data for Fiscal Year 2006 for the following:

- FY 2006 Income Limits, effective March 8, 2006, at
<http://www.huduser.org/datasets/il.html>
- FY 2006 Fair Market Rents, effective March 6, 2006, at
<http://www.huduser.org/datasets/fmr.html>

(Note: The information can also be accessed on www.hudclips.org)

#10- RHIP Tip (Dependent Deductions); Publications (Rent Schedule and IRS-Notice 2005-69; and RHIP Listserv Memo – March 8, 2006

RHIP Tip: Dependent Deductions

The head of the family, the spouse, and the co-head may never qualify as dependents.

A foster child, an unborn child, a child who has not yet joined the family, or a live-in aide may never be counted as a dependent.

For additional information about calculating adjusted income and dependent deductions, please refer to Chapter 5, paragraph 5-10. A.2 of HUD Handbook 4350.3 REV1, Occupancy Requirements of Subsidized Multifamily Housing Programs

[http://www.hudclips.org/sub_nonhud/cgi/hudclips_exp_coll.cgi?query_str=expand&d=HBNT&s1=\(4350.3\)\[no\]&l=100&SECT1=TXT_HITS&SECT5=HCHB&u=./hudclips.cgi&p=1&r=S&f=S](http://www.hudclips.org/sub_nonhud/cgi/hudclips_exp_coll.cgi?query_str=expand&d=HBNT&s1=(4350.3)[no]&l=100&SECT1=TXT_HITS&SECT5=HCHB&u=./hudclips.cgi&p=1&r=S&f=S)

PUBLICATIONS:

1. The new OMB approved Form HUD-92458, Rent Schedule Low Rent Housing is now posted on HUDCLIPS at <http://www.hudclips.org/cgi/index.cgi>. The form, dated November 2005, has been revised to omit the SSN/EIN column because this information is no longer necessary to process the rent schedule since it is available in other HUD sources. Owners/agents will not be required to re-submit the Rent Schedule on the revised version if the old version (with the SSN/EIN) has already been submitted.

2. IRS Notice 2005-69 has been issued providing relief from certain low-income housing credit requirements due to Hurricane Katrina. A temporary suspension of certain income limitation requirements has been granted for qualified low-income housing projects in which vacant units have been rented to displaced individuals. The notice can be found at <http://www.irs.gov/pub/irs-drop/n-05-69.pdf>

ITEMS OF INTEREST: HUD Memo Regarding Newly Created RHIP Listserv

1. HUD Memo Regarding Newly Created RHIP Listserv

The Memorandum dated February 16, 2006, from Charles H. Williams, Deputy Assistant Secretary for Multifamily Programs to the HUD Multifamily Hub and Program Center Directors, promoting the RHIP Listserv can be viewed at <http://www.hud.gov/offices/hsg/mfh/rhiip/mfhrhiip.cfm>).

2. RHIP Listserv Archive

The weekly Listserv postings will be archived on the Multifamily RHIP webpage after every 10 postings at <http://www.hud.gov/offices/hsg/mfh/rhiip/mfhrhiip.cfm>

#9 – Public Comment for Special Claims Processing - March 2, 2006

ITEMS OF INTEREST: Federal Register Seeking Public Comment regarding

Notice of Submission of Proposed Information Collection to OMB; Applications for Housing Assistance Payments: Special Claims Processing

Federal Register Document Number: FR-5037-N-10

Date: 20060224

The proposed information collection requirement described below has been submitted to the Office of Management and Budget (OMB) for review, as required by the Paperwork Reduction Act. The Department is soliciting public comments on the subject proposal.

Owners/agents submit vouchers to HUD or their Contract Administrators (CA)/Performance Based Contract Administrators (PBCA) monthly to receive assistance payments for the difference between the gross rent and the total tenant payment for all assisted tenants. Special claims vouchers are also submitted by owners/agents to HUD or their CA/PBCA to receive an amount to offset unpaid rent, tenant damages, vacancies, and/or debt service losses.

Interested persons are invited to submit comments regarding this proposal. Comments should refer to the proposal by name and/or OMB approval Number (2502-0182) and should be sent to: HUD Desk Officer, Office of Management and Budget, New Executive Office Building, Washington, DC 20503; fax: 202-395-6974.

FOR FURTHER INFORMATION CONTACT: Lillian Deitzer, Reports Management Officer, AYO, Department of Housing and Urban Development, 451 Seventh Street, SW., Washington, DC 20410; e-mail Lillian Deitzer at Lillian_L_Deitzer@HUD.gov or telephone (202) 708-2374. This is not a toll-free number. Copies of available documents submitted to OMB may be obtained from Ms. Deitzer.

DATES: Comments Due March 27, 2006.

The Federal Register documents can be viewed at <http://www.hudclips.org/cgi/index.cgi>

#8 – RHIP Tip (Resident Services Stipends); and Enrollment for Medicare Prescription Drug Coverage - March 2, 2006

RHIP Tip:

Resident services stipends are generally modest amounts of money received by residents for performing services such as hall monitoring, fire patrol, lawn maintenance, and resident management.

1. If the resident stipend exceeds \$200 per month, owners must include the entire amount in annual income.
2. If the resident stipend is \$200 or less per month, owners must exclude the entire amount in annual income.

For additional information about calculating income and the elements of annual income, please refer to Chapter 5, paragraph 5-6.L. of HUD Handbook 4350.3 Occupancy Requirements of Subsidized Multifamily Housing Programs.

[http://www.hudclips.org/sub_nonhud/cgi/hudclips_exp_coll.cgi?query_str=expand&d=HBNT&s1=\(4350.3\)\[no\]&l=100&SECT1=TXT_HITS&SECT5=HCHB&u=./hudclips.cgi&p=1&r=S&f=s](http://www.hudclips.org/sub_nonhud/cgi/hudclips_exp_coll.cgi?query_str=expand&d=HBNT&s1=(4350.3)[no]&l=100&SECT1=TXT_HITS&SECT5=HCHB&u=./hudclips.cgi&p=1&r=S&f=s)

ITEMS OF INTEREST: Update on Enrollment For Medicare Prescription Drug Coverage

HUD recently received an e:mail from the Department of Health and Human Services with the following information:

Today, HHS Secretary Mike Leavitt announced updated enrollment numbers for the Medicare prescription drug benefit at a community event in Pensacola, Florida.

The number of Medicare beneficiaries receiving prescription drug coverage continues to grow with more than 25 million Medicare beneficiaries now covered, well on track toward the goal of 28 to 30 million enrollees in the first year. This number reflects more than 5.3 million beneficiaries who have signed up individually for prescription drug coverage in the last three months, including 1.5 million who signed up in the last 30 days. Most of the new enrollees in stand-alone drug plans chose plans offering other than the "standard" drug benefit. Many beneficiaries chose coverage with low or no deductible, fixed co-pays for most prescriptions instead of coinsurance, or coverage in the coverage gap or "donut hole."

"The promise of the new Medicare law is being realized for more than 25 million Medicare beneficiaries who are getting help paying for the medicines they need," HHS Secretary Mike Leavitt said. "We are encouraged by the millions of people who are enrolling each month, even as we continue to reach out to those who have not yet signed up but can benefit from the new program."

"We've seen enrollment continue at a steady pace, faster than what we saw before the late December surge," said Centers for Medicare & Medicaid Services Administrator Mark B. McClellan, M.D., Ph.D. CMS continues to urge Medicare beneficiaries to sign up for drug coverage early in the month before they want coverage, or at least 2 to 3 weeks before they plan to use their coverage. "Signing up before the 15th makes it more likely that you will get your prescriptions filled quickly the first time you use your coverage," Dr. McClellan said. "We want everyone to get the most out of their coverage starting the first time they go to the drug store." The enrollment period continues through May 15, 2006.

The overall drug benefit enrollment figures as of Feb. 13 are:

- Stand-alone Prescription Drug Plans: about 4.9 million (1.3 million since Jan. 13)

- Medicare/Medicaid: 6.2 million (including 560,000 in Medicare Advantage plans).
- Medicare Advantage: 4.7 million plus 560,000 in Medicare/Medicaid.
- Retiree coverage: About 6.4 million retirees are enrolled in the Medicare retiree subsidy. As previously stated, another 1 million retirees are in employer coverage that incorporates or supplements Medicare's coverage. Another estimated 500,000 retirees are continuing in coverage that is as good as Medicare's.
- TRICARE/ FEHB retirees: 3.1 million.

The fact sheet with current state-specific enrollment numbers can be found at <http://hhs.gov/news/press/2006.html>.

#7 – RHIP Tip (Income Exclusion); 2006 OMB Report; and Submission of Annual Financial Statements for Multifamily Housing Property Owners - February 23, 2006

RHIP Tip: INCOME EXCLUSION

What is the Earned Income Tax Credit (EITC)?

The EITC is a special income tax benefit for people who work full or part-time. For those who qualify, less federal taxes will be owed and the person filing could get a partial refund. Even if a person does not owe income tax, they might be eligible for the EITC, but a federal tax return must be filed. For more information about the EITC and help with filing a return, visit the Internal Revenue Service (IRS) website at www.irs.gov/eitc or call IRS toll-free at 1-800-829-1040 for the location of a Volunteer Income Tax Assistance (VITA) center near you.

If a person receives an EITC refund, will this amount be counted as income to HUD?

NO. The EITC refund payment is not counted as income and is excluded in the tenant calculations for determining the rent amount.

For additional information about other income exclusions, please see Exhibit 5-1: Income Inclusions and Exclusions in Chapter 5, Determining Income & Calculating Rent of HUD Handbook 4350.3 REV-1, Occupancy Requirements of Subsidized Multifamily Housing Programs.

ITEMS OF INTEREST:

2006 OMB Report:

In fiscal year 2005, substantial progress was made in meeting the President's goal to eliminate improper payments as documented in a report dated February 2, 2006, from the Office of Management and Budget. The report "Improving the Accuracy and Integrity of Federal Payments" can be found at http://www.whitehouse.gov/omb/financial/fia_improper.html under "OTHER GUIDANCE".

Submission of Annual Financial Statements for Multifamily Housing Property Owners:

As you are aware, March 1st is the time for some owners to submit their annual audited financial statements and this date is quickly approaching. Some owners/management agents may not have kept their users, coordinators, or passwords up-to-date, therefore system access is always a significant factor just before submission.

It is strongly encouraged that you check your system access capability/passwords well in advance of submission (i.e., during the month of February) so that any issues can be worked out in a timely manner. If you encounter any problems, please contact the Technical Assistance Center (TAC) at the Real Estate Assessment Center (REAC) at the following telephone number: 888-245-4860.

#6 – RHIP Tip (Eligibility for Assistance and Occupancy) - February 16, 2006

RHIP TIP ON ELIGIBILITY FOR ASSISTANCE AND OCCUPANCY: Facts about Children:

1. Did you know that applicants must disclose social security numbers for all family members at least 6 years of age and older and provide proof of the numbers reported?

--Chapter 3, Eligibility for Assistance and Occupancy, Section 3-5 B of HUD Handbook 4350.3 Occupancy Requirements of Subsidized Multifamily Housing Programs

2. When determining the size of unit that would be appropriate for a particular family, the owner must count "Children in joint custody arrangements who are present in the household 50% or more of the time."

--Chapter 3, Eligibility for Assistance and Occupancy, Section 3-22 E6. b(6) of HUD Handbook 4350.3 Occupancy Requirements of Subsidized Multifamily Housing Programs

For additional information about eligibility for assistance and occupancy, please refer to Chapter 3 of HUD Handbook 4350.3 REV1, Occupancy Requirements of Subsidized Multifamily Housing Programs.

[http://www.hudclips.org/sub_nonhud/cgi/hudclips_exp_coll.cgi?query_str=expand&d=HBNT&s1=\(4350.3\)\[no\]&l=100&SECT1=TXT_HITS&SECT5=HCHB&u=./hudclips.cgi&p=1&r=S&f=S](http://www.hudclips.org/sub_nonhud/cgi/hudclips_exp_coll.cgi?query_str=expand&d=HBNT&s1=(4350.3)[no]&l=100&SECT1=TXT_HITS&SECT5=HCHB&u=./hudclips.cgi&p=1&r=S&f=S)

#5 – RHIP Tip (Medical Expenses) - February 9, 2006

RHIP TIP ON MEDICAL EXPENSES:

Did you know that transportation expenses to/from treatment and lodging is an eligible item for medical expense deductions? These types of expenses may include the actual cost (e.g. bus fare) or, if driving in a car, a mileage rate based on IRS rules or other accepted standard.

If the IRS mileage rate was used in calculating the transportation expense for driving a car, please refer to the 2006 mileage rate that was released by the IRS on December 2, 2005. The rate for computing deductible medical expenses has increased from 15 cents to 18 cents a mile. The IRS press release can be found at <http://www.irs.gov/newsroom/article/0,,id=151226,00.html>

For additional information about eligible medical expenses, please refer to Chapter 5 Exhibit 5-3 Medical Expenses That Are Deductible and Nondeductible HUD Handbook 4350.3 REV1, Occupancy Requirements of Subsidized Multifamily Housing Programs [http://www.hudclips.org/sub_nonhud/cgi/hudclips_exp_coll.cgi?query_str=expand&d=HBNT&s1=\(4350.3\)\[no\]&l=100&SECT1=TXT_HITS&SECT5=HCHB&u=./hudclips.cgi&p=1&r=S&f=S](http://www.hudclips.org/sub_nonhud/cgi/hudclips_exp_coll.cgi?query_str=expand&d=HBNT&s1=(4350.3)[no]&l=100&SECT1=TXT_HITS&SECT5=HCHB&u=./hudclips.cgi&p=1&r=S&f=S)

#4 – FEMA New Releases (Katrina and Rita); and the National Low Income Housing Coalition (NLIHC) Listserv - February 2, 2006

ITEMS OF INTEREST:

1. FEMA News Releases

On January 27, 2006, the Department of Federal Emergency Management Agency (FEMA) released news pertaining to Hurricane Katrina and Rita evacuees and temporary housing deadlines. To view this recent release along with a number of other recent releases dated January 26th thru January 30th, please visit <http://www.fema.gov/news/recentnews.fema>

Additional information regarding HUD's involvement in assisting the evacuees and coordinating the identification of housing opportunities can be found at <http://www.hud.gov/news/katrina05response.cfm>.

2. The National Low Income Housing Coalition (NLIHC) Launches Listserv for Housing Advocates

An email Listserv has been established to help advocates helping hurricane victims deal with temporary and long-term re-housing issues communicate with each other. The group is meant to be a vehicle through which advocates can exchange information, concerns and resources as they assist individuals who are dealing with FEMA and HUD, help evacuees find adequate, affordable housing, or working toward ensuring affordable housing has a place in the rebuilding of affected areas.

The group may be joined by sending an email to: katrina_rehousingsubscribe@yahoogroups.com

#3 – Medicare Prescription Drug Benefit - January 24, 2006

ITEMS OF INTEREST:

The Department of Health and Human Services recently sent HUD an email with the following information:

On Thursday, January 19, 2006, Medicare released state-by-state data reflecting enrollment in the Medicare prescription drug benefit that began on January 1, 2006. Pharmacists around the country are filling a million prescriptions a day, and many seniors are reporting that they are already saving money from the benefit.

In total, more than 24 million people with Medicare across the U.S. now have prescription drug coverage through Medicare Advantage Plans, new stand-alone prescription drug plans, and employer and union plans. More than 2.6 million people signed up for the new stand-alone prescription drug plans in the last 30 days, on top of the 1 million who had enrolled in the first 30 days of the program.

National drug benefit enrollment figures as of January 13 are:

Stand-Alone Prescription Drug Plans: about 3.6 million (2.6 million since Dec. 13)

Medicare/Medicaid: 6.2 million, including 600,000 in Medicare Advantage plans (not included below)

Medicare Advantage: 4.5 million (plus 600,000 Medicare/Medicaid beneficiaries included above)

Retiree coverage: About 6.4 million retirees are enrolled in the Medicare retiree subsidy. Also, as stated last month, about 1 million retirees are in employer coverage that incorporates or supplements Medicare's coverage. Another estimated 500,000 retirees are continuing in coverage that is as good as Medicare's.

TRICARE/ FEHB retirees: 3.1 million

The fact sheet with state-specific enrollment numbers as of January 13, 2006 can be found at <http://www.cms.hhs.gov/center/press.asp>. Please note that in the state table, the 600,000 Medicare/Medicaid beneficiaries are included in the Medicare Advantage column rather than with Medicare/Medicaid, as above.

#2 – Publications (Notice H-2005-21 for Medicare Prescription Drug Plan, Final Rule on Student Eligibility, and HUD-9834(Management and Occupancy Review Form) - January 20, 2006

PUBLICATIONS: (Posted on the RHIP website at <http://www.hud.gov/offices/hsg/mfh/rhiip/mfhrhiip.cfm>) and/or HUDCLIPS at <http://www.hudclips.org/cgi/index.cgi>

- The following joint Notice between Housing and Public and Indian Housing is posted on HUDCLIPS.

Notice: H-2005-21

Income calculation and verification guidance regarding the Medicare Prescription Drug Plan - Part D Program

Issued: December 9, 2005

Expires: December 31, 2006

- A Final Rule has been published in the Federal Register dated December 20, 2005, regarding Eligibility of Students for Assisted Housing under Section 8 of the U.S. Housing Act of 1937.

The new OMB approved Form HUD-9834, Management Review for Multifamily Housing Projects is now posted on HUDCLIPS.

#1 – New RHIP Listserv - January 13, 2006

Thank you for subscribing to the HUD Multifamily Housing RHIP TIPS Listserv. We are still in the development process of this listserv, and do not plan to begin distribution until early Fiscal Year 2006.

If you should have any occupancy related question, please contact your assigned contract administrator, or your RHIP Help Desk Representative. To find a list of the RHIP Help Desk Representatives, please visit: <http://www.hud.gov/offices/hsg/mfh/rhip/helpdesk.pdf>

In the interim, you can view the latest RHIP information at:
<http://www.hud.gov/offices/hsg/mfh/rhip/mfhrhip.cfm>